



350 S. St. Charles St. Jasper, In. 47546
Ph. 812.482.2932 Fax 812.634.6632

www.ridetech.com

Part # 11290298
65-66 Impala Air Suspension System

Front Components:

1	11283001	HQ Series Front Shockwaves
1	11282899	Front Lower StrongArms
1	11283699	Front Upper StrongArms
1	11289100	Front MuscleBar Sway Bar w/ PosiLinks

Rear Components:

1	11284699	Rear CoolRide Kit for StrongArms
1	11280701	HQ Series Rear Shocks
1	11284499	Rear Lower StrongArms
1	11296699	Rear Upper StrongArm & Panhard Bar Kit
1	11289102	Rear MuscleBar Sway Bar



Part # 11283001 - 65-70 GM B-Body Front HQ Series Shockwave

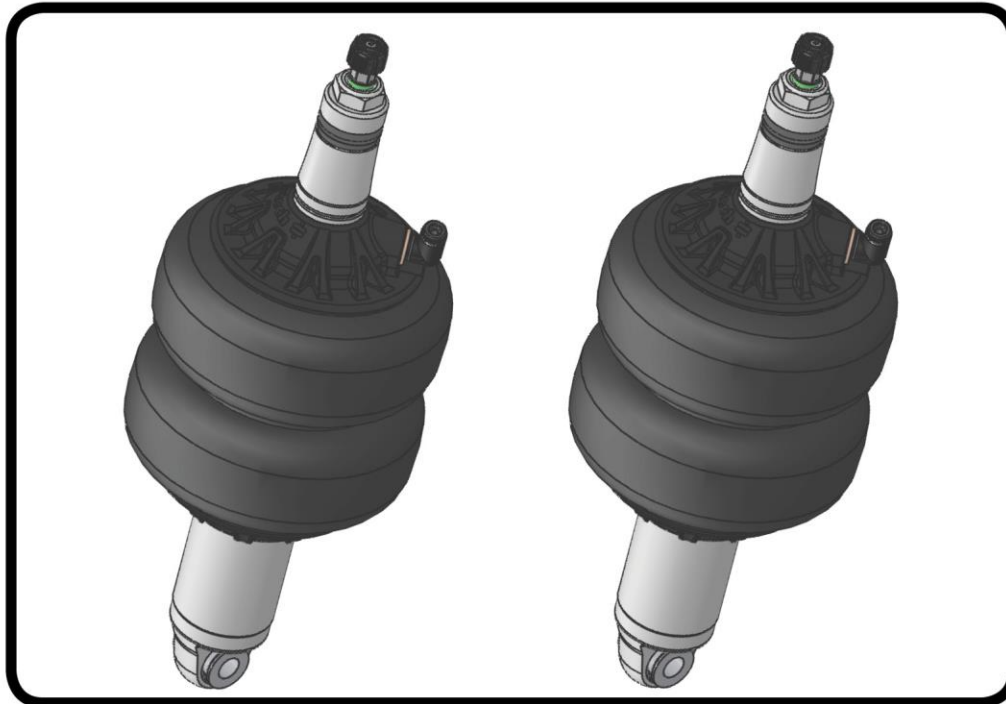

Recommended Tools



1000 Series Bellow, 2.75" Stud/Eye 3.6" Shock Installation Instructions

Table of contents

Page 2..... Included components

Page 3-4..... Shockwave Installation

Page 5-6..... Notes and Care of Your Shockwave & Shock Adjustment

ShockWave Dimensions:

Center of bearing to Center of bearing:

Compressed: 11.175"

Ride Height: 12.975"

Extended: 14.050"

THE DELRIN BALL REQUIRES A 3/4" HOLE FOR THE FLANGE TO GO THROUGH. THIS CAN BE DRILLED WITH A UNIBIT.

www.ridetech.com
812-482-2932





Major ComponentsIn the box

Item #	Part #	Description	QTY
1	24139999	3.6" Stroke HQ Series Shock	2
2	90009989	2.75" Stud Top (Installed on Shock) - Includes Adjuster Knob & Screw	2
3	24090199	1000 Series 6.5" Double Convoluted AirSpring	2
4	70010893	AirSpring Locking Ring (Installed on shock)	2
5	99055000	Locking Ring Set Screw (Installed on shock)	2
6	90002062	Spacers - INCLUDED WITH STRONGARMS	4
7	90002313	2.75" Aluminum Stud Top Base	2
8	90001904	Bottom Delrin Ball	2
9	90001903	Top Delrin Ball	2
10	90001902	Delrin Ball Aluminum Top Cap	2
11	99562003	9/16" -18 Thin Nylok Nut	2
12	90009972	Adjuster Knob - (90009989 assembly)	2
13	90009969	#4-40 X 1/4" SS, 18-8 Pan Head Torx Cap - (90009989 assembly)	2
14	90006782	Stud Top Spacer	2
	70012161	2.75" Stud Top Metering Rod (installed in stud top)	2
	90001994	5/8" ID Bearing (installed in shock and eyelet)	4
	90001995	Bearing Snap Ring (installed in shock and eyelet)	8

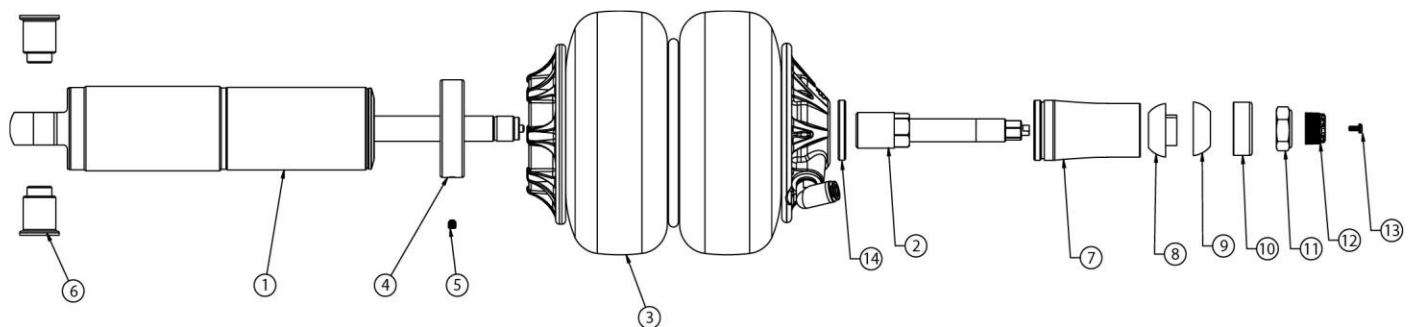

THE DELRIN BALL REQUIRES A 3/4" HOLE FOR THE FLANGE TO GO THROUGH. THIS CAN BE DRILLED WITH A UNIBIT.

WARNING: ATTEMPTING TO REMOVE THE AIR FITTING WILL DAMAGE IT AND VOID THE WARRANTY.



ShockWave Installation

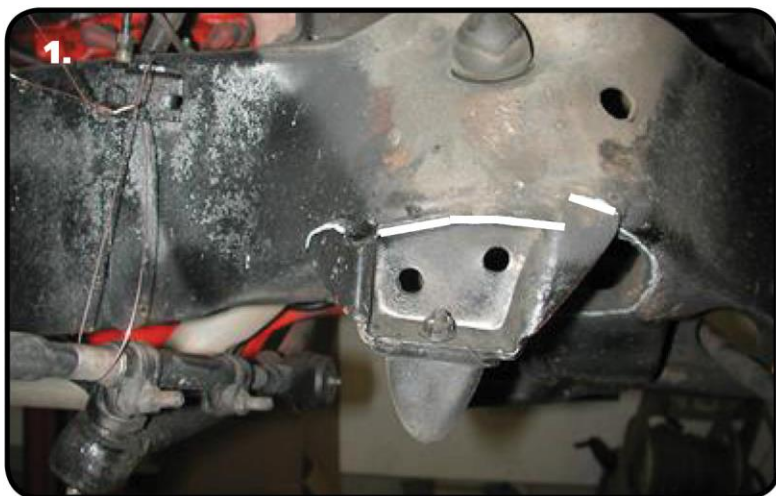

1. The Shockwave bellow will rub the frame, so some trimming must be done. Using a die grinder, remove the bump stop bracket from the coil spring pocket.

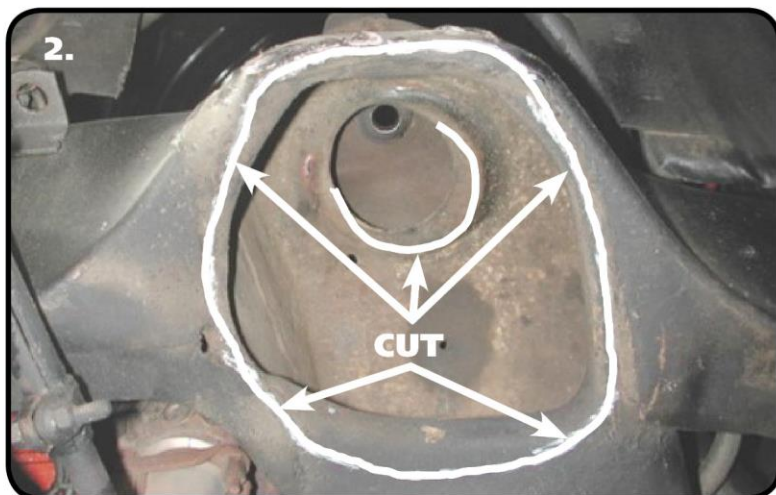

2. The inside lip of the pocket must also be removed to allow for Shockwave bellow clearance. Also, the coil spring retainer needs to be trimmed for the swivel stud top clearance.



3. Surrounding the hole that the factory shock stem went through is a bushing cup. This must be removed using a chisel or air hammer. After removing, drill the frame out to 3/4". A Unibit works well for this.



ShockWave Installation

4.

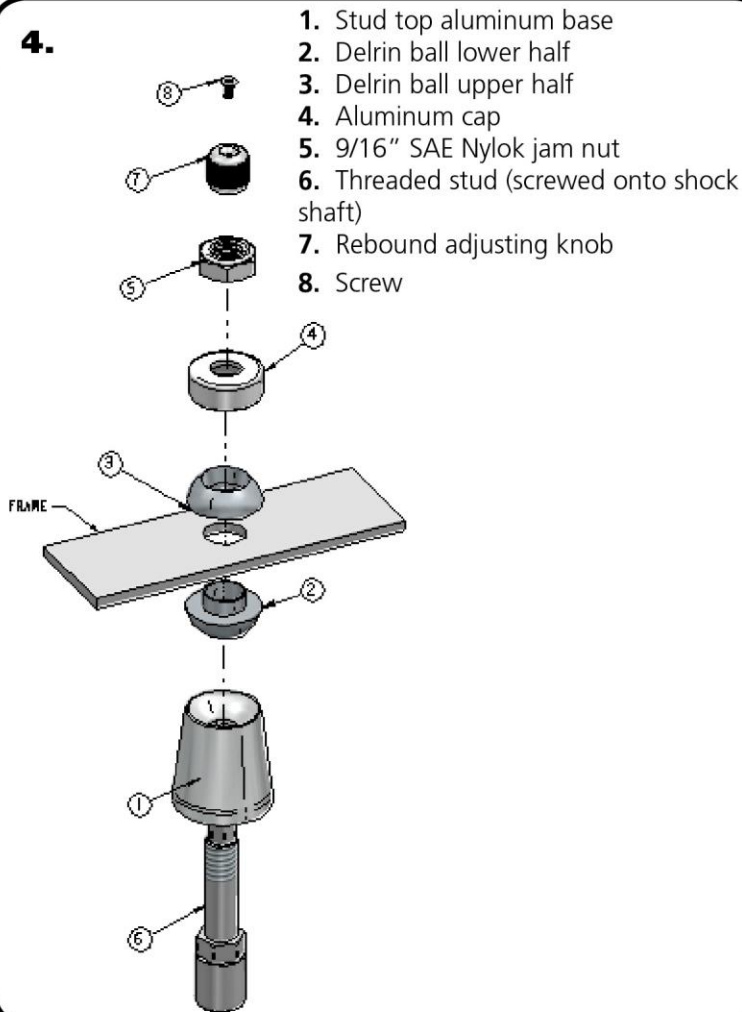

1. Stud top aluminum base
2. Delrin ball lower half
3. Delrin ball upper half
4. Aluminum cap
5. 9/16" SAE Nylok jam nut
6. Threaded stud (screwed onto shock shaft)
7. Rebound adjusting knob
8. Screw

Note: The airline must also be routed at this time. It can be ran through the subframe toward the rear of the vehicle.

4. The air fitting location can be rotated by twisting the bellow assembly separate of the shock. Place the Shockwave into the coil spring pocket with the stud sticking through the OEM shock hole. See assembly **Diagram 4**. OEM Shock hole **must** be drilled out to $\frac{3}{4}$ "

1. Stud top aluminum base
2. Delrin ball lower half
3. Delrin ball upper half
4. Aluminum cap
5. 9/16" SAE Nylok jam nut
6. Threaded stud (screwed onto shock shaft)
7. Rebound adjusting knob
8. Screw

5. Raise the lower arm up to the Shockwave and bolt them together using the $\frac{1}{2}$ " x $3\frac{1}{4}$ " bolt and Nylok supplied w/ the lower arms. An aluminum spacer will be on each side of the bearing. Torque to 75 ftbs.

5.

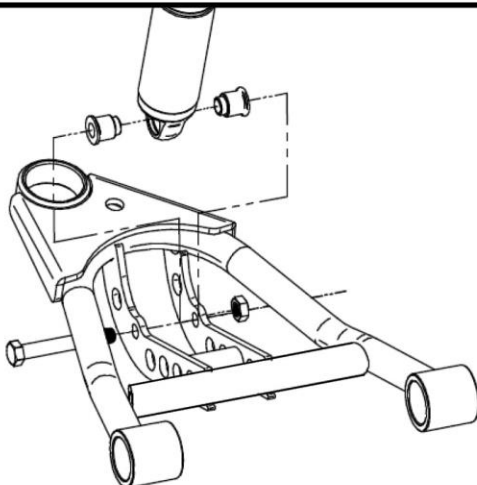

6. Raise the lower control arm to full compression and double-check to make sure the Shockwave does not rub on anything at any-time. Allowing the Shockwave to rub on anything will cause failure and is not a warrant-able situation.

7. The best ride quality will occur around 50-60% suspension travel; depending on vehicle weight this typically occurs around 100 psi.



Notes and Care of your Shockwaves

NOTES:

WARNING: ATTEMPTING TO REMOVE THE AIR FITTING WILL DAMAGE IT AND VOID THE WARRANTY.

TIGHTENING THE TOP 9/16"-18 NUT: SNUG THE NUT DOWN AGAINST THE TOP CAP. YOU NEED TO BE ABLE TO ARTICULATE THE SHOCK BY HAND.

You can clock the airfitting location on the ShockWave by turning the AirSpring assembly of the shock. Make sure the fitting doesn't contact the frame.

When cutting the airline, use a razor blade. The cut needs to be a clean cut and square for the airline to seal properly.

The Locking ring on the shock is **NOT** adjustable. These rings are set at the factory to optimize the AirSpring stroke with the shock stroke.

The care and feeding of your new ShockWaves

1. Although the ShockWave has an internal bumpstop, **DO NOT DRIVE THE VEHICLE DEFLATED RESTING ON THIS BUMPSTOP. DAMAGE WILL RESULT.** The internal bumpstop will be damaged, the shock bushings will be damaged, and the vehicle shock mounting points may be damaged to the point of failure. This is a non warrantable situation.
2. Do not drive the vehicle overinflated or "topped out". Over a period of time the shock valving will be damaged, possibly to the point of failure. This is a non warrantable situation! If you need to raise your vehicle higher than the ShockWave allows, you will need a longer unit.
3. The ShockWave is designed to give a great ride quality and to raise and lower the vehicle. **IT IS NOT MADE TO HOP OR JUMP!** If you want to hop or jump, hydraulics are a better choice. This abuse will result in bent piston rods, broken shock mounts, and destroyed bushings. This is a non warrantable situation.
4. Do not let the ShockWave bellows rub on anything. Failure will result. This is a non warrantable situation.
5. The ShockWave product has been field tested on numerous vehicles as well as subjected to many different stress tests to ensure that there are no leakage or durability problems. Failures have been nearly nonexistent unless abused as described above. If the Shockwave units are installed properly and are not abused, they will last many, many years. ShockWave units that are returned with broken mounts, bent piston rods, destroyed bumpstops or bushings, or abrasions on the bellows will not be warrantied.



Shock Adjustment

Shock adjustment 101- Single Adjustable

Rebound Adjustment:

How to adjust your new shocks.

The rebound adjustment knob is located on the top of the shock absorber protruding from the eyelet.

You must first begin at the ZERO setting, then set the shock to a soft setting of 20.



-Begin with the shocks adjusted to the ZERO rebound position (full stiff). Do this by rotating the rebound adjuster knob clockwise until it stops.



-Now turn the rebound adjuster knob counter clock wise 20 clicks. This sets the shock at 20. (settings 21-24 are typically too soft for street use).

Take the vehicle for a test drive.



-if you are satisfied with the ride quality, do not do anything, you are set!

-if the ride quality is too soft increase the damping effect by rotating the rebound knob clock wise 3 clicks. **CONTINUE ON NEXT PAGE.**

Take the vehicle for another test drive.



-if the vehicle is too soft increase the damping effect by rotating the rebound knob clock wise 3 additional clicks.



-If the vehicle is too stiff rotate the rebound adjustment knob counter clock wise 2 clicks and you are set!

Take the vehicle for another test drive and repeat the above steps until the ride quality is satisfactory.

Note:

One end of the vehicle will likely reach the desired setting before the other end. If this happens stop adjusting the satisfied end and keep adjusting the unsatisfied end until the overall ride quality is satisfactory.

STILL HAVE QUESTIONS?

Tech line hours

Monday - Friday

8AM - 6PM (EST) 812-482-2932



350 S. St. Charles St. Jasper, In. 47546
Ph. 812.482.2932 Fax 812.634.6632

www.ridetech.com

Part # 11282899
65-70 Impala Front Lower StrongArms
For use w/ Shockwaves or CoilOvers

Components:

1	90000093	Driver side lower arm
1	90000094	Passenger side lower arm
2	90002586	Ball joint
2	90000928	Bushing
2	90001045	Control arm pivot bearing
2	90000734	Bearing housing
2	90000735	Bearing retaining plate
2	90000733	Aluminum bearing spacer
2	90000732	Bearing stud (Set to 3 1/16")
4	90002062	Aluminum spacer – Shock to lower arm

Hardware:

2	99752001	3/4"-16 Lock nut Gr.8	Pivot bearing
2	99752004	3/4"-16 Jam nut	Pivot bearing
2	99753001	3/4" Flat washer	Pivot bearing
6	99371018	3/8" x 1 1/4" SHCS	Pivot bearing
6	99373005	3/8" Lock washer	Pivot bearing
2	99501024	1/2" x 3 1/4" SAE Gr. 8 bolt	Shockwave to lower arm
2	99502001	1/2"-13 Nylok nut	Shockwave to lower arm
2	99371004	3/8" x 1 1/4" USS bolt	Steering stop
2	99372004	3/8" USS regular nut	Steering stop

Installation Instructions

1. Raise and support vehicle at a safe, comfortable working height. Let the front suspension hang freely.
2. Remove the coil spring, shock absorber, upper and lower control arms, sway bar and the strut rods. **There is a washer on each side of the lower control arm frame bushing, these will be reused. The factory lower control arm bolt will be reused as well.**

Note: This kit is designed for use with our MuscleBar sway bar. It is easier to install it **before** the lower arms. The factory sway bar will not fit.



3. Bolt the lower StrongArm to the frame using the factory bolt. **Be sure to reinstall the T washers that came off the factory arm bushing.**

4. The front leg of the lower arm will attach to the frame in place of the strut rod. Refer to the diagram on the next page for assembly order.

Note: The hole in the frame may need to be buffed to allow bearing assembly to slide in.

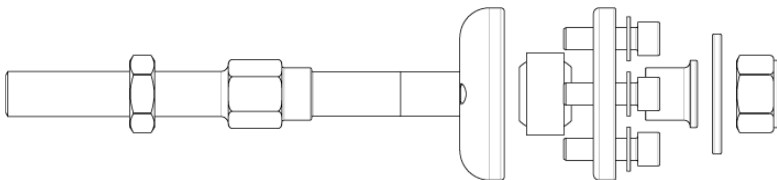

5. Using the bearing retainer as a template; drill three 3/8" holes in the frame to secure the assembly. Use three 3/8" x 1 1/4" SHCS and lock washers to secure the assembly.



6. Attach the Shockwave to the lower control arm using a $\frac{1}{2}$ " x 3" bolt and Nylok jam nut. An aluminum spacer must be installed on each side of the bearing.

7. Two $\frac{3}{8}$ " x $1\frac{1}{4}$ " bolts and nuts are supplied for the steering stop. They will bolt to the rear side of the ball joint plate. This can be adjusted to limit steering radius.



8. The Caster setting on this system has a lot of adjustment. We recommend setting it at 3-3.5 degrees.

9. Driving height pressure should be around 100psi. 6-8 clicks in the shocks will be a good starting point. This will vary to vehicle weight and driver preference.

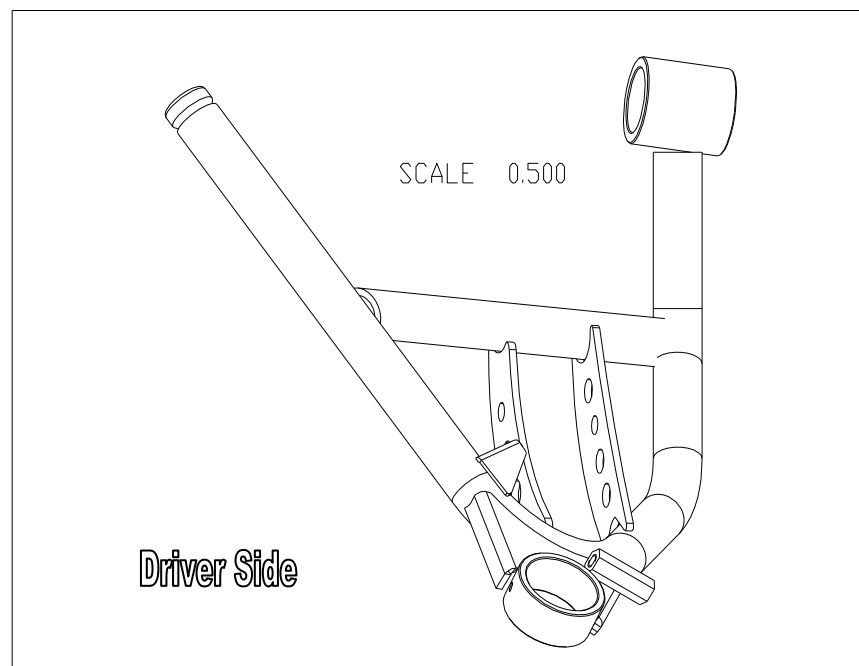



350 S. St. Charles St. Jasper, In. 47546
Ph. 812.482.2932 Fax 812.634.6632

www.ridetech.com

Part # 11283699
65-70 Impala Front Upper StrongArms

Components:

1	90000478	Driver side upper arm
1	90000479	Passenger side upper arm
2	90000905	Ball joint
2	90000907	Bushing kit (4 pieces)
2	90000102	Cross shaft

Hardware:

4	99373005	3/8" Lock washer	Upper cross shaft
4	99371013	3/8" x 1" SAE bolt	Upper cross shaft
4	99373001	3/8" fender washer	Upper cross shaft

Installation Instructions



1. Drop the ball joint down through the ball joint plate, secure w/ the hardware supplied.
2. Fasten the upper arm to the frame using the factory hardware. Reinstall the current alignment shims, but **vehicle must be realigned**. This arm was designed with an extra 2 degrees of positive caster allowing the car to be aligned with up to 4 degrees of positive caster. (This will vary from car to car.)

Driver Side – Top View

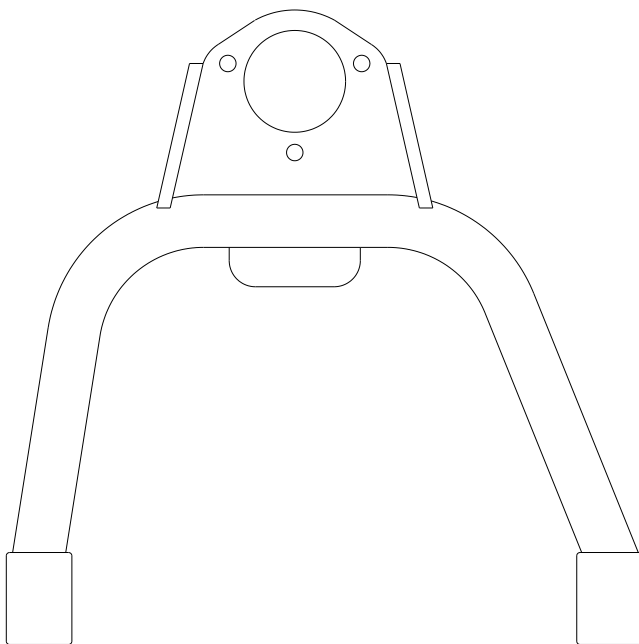

3. Insert the ball joint stud through the spindle and install new castle nut and cotter pin supplied.
4. Thread Zerk fitting into ball joint and grease.
5. Position the suspension at mid travel and then tighten the cross shaft nuts.

STRONG ARMS™

by Air Ride Technologies

Item #	Description	Qty.
1.	Passenger side arm	1
1.	Driver side arm	1
2.	Cross shaft	2
3.	Cross shaft bushing	4
4.	Ball joint	2
5.	5/16"-24 x 1" hex bolt	6
6.	5/16"-24 hex nut	6
7.	5/16" lock washer	6
8.	3/8"-24 x 1" hex bolt	4
9.	3/8" lock washer	4
10.	3/8" x 1.5" flat washer	4

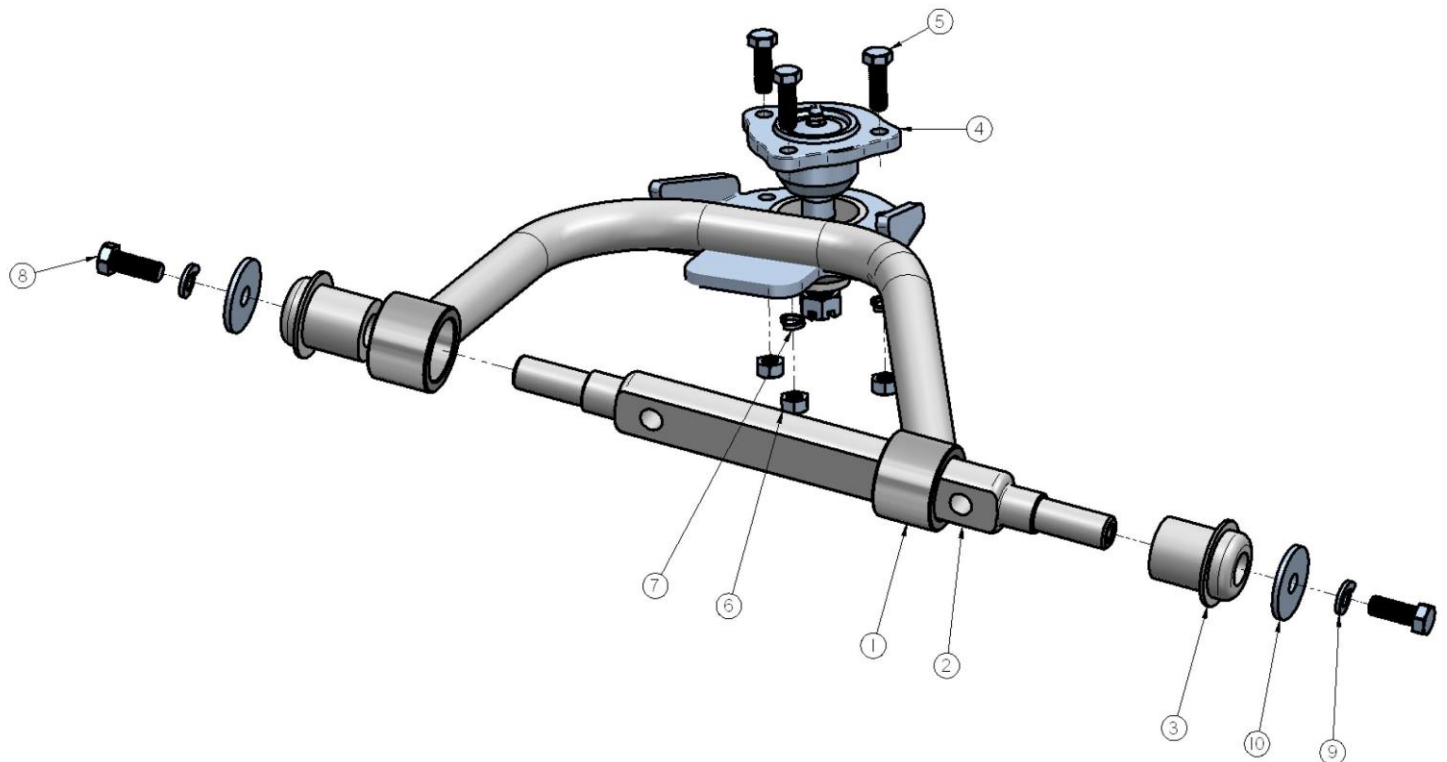



350 S. St. Charles St. Jasper, In. 47546

Ph. 812.482.2932 Fax 812.634.6632

www.ridetech.com

Part # 11289100
65-70 Impala Front MuscleBar

Components:

1	90000104	Sway bar
2	90001100	Bushing and strap kit
2	90000929	12mm end link
2	90001092	Tube of Lithium grease

Hardware:

2	99122001	12mm x 1.75 Lock nut	PosiLink to sway bar
4	99433002	7/16" SAE flat washer	PosiLink to sway bar
2	99122007	12mm lock washer	PosiLink to lower arm
4	99371004	3/8" x 1 1/4" USS bolt	Frame bracket
4	99372002	3/8" USS Nylok nut	Frame bracket
8	99373003	3/8" SAE flat washer	Frame bracket

MUSCLEbarTM
by Air Ride Technologies

MUSCLEbar™

by Air Ride Technologies

Installation Instructions

*****This sway bar is designed for use with our front StrongArms*****



1. Slide the sway bar through the same holes in the frame that the factory bar went through.
2. Install the new polyurethane bushing over the sway bar. Lubricate with the Lithium grease supplied.
3. Slide the frame bracket over the bushings and clamp the sway bar up to the frame using a couple "C" clamps. The sway bar should be centered in the hole through the frame.



4. Adjust the frame bracket so that the corner of the bracket is flush with the outside of the frame rail.
5. The factory bolt holes will not be used. Two new holes must be drilled with a 3/8" bit.
6. Secure the assembly with two 3/8" x 1 1/4" bolts, flat washers and Nylok nuts.



7. Install the lower StrongArms.

8. Screw one end of the PosiLink into the end of the sway bar. A 12mm lock washer will be used between the stud and the sway bar.



9. The other end of the PosiLink will attach to the tab on the StrongArm using a 12mm flat washer and locking nut.

10. Check sway bar clearance through full suspension travel.

11. Congratulations!! Your New MuscleBar installation is now complete. If you have any further questions feel free to contact us at 812-482-2932.



ridetech

350 S. St. Charles St. Jasper, In. 47546

Ph. 812.482.2932 Fax 812.634.6632

www.ridetech.com

Part # 11284699

65-70 Impala Rear CoolRide

For Use w/ Lower StrongArms

Components:

2	90006781	267c Air spring
2	90000024	Upper air spring bracket
2	90000224	Upper bracket frame washer

Hardware:

2	99435001	7/16 x 6" stud	Upper air spring bracket to frame
2	99432001	7/16" USS Nylok nut	Upper air spring bracket to frame
2	99433002	7/16" flat washer	Upper air spring bracket to frame
2	99372002	3/8" USS Nylok nut	Air spring to upper bracket
2	99371001	3/8" x 3/4" USS bolt	Air spring to lower arm
6	99373003	3/8" flat washer	Air spring
2	99373005	3/8" lock washer	Air spring to lower arm

COOLRiDE[®]

by Air Ride Technologies

*** For use w/ RideTech shock kit ***

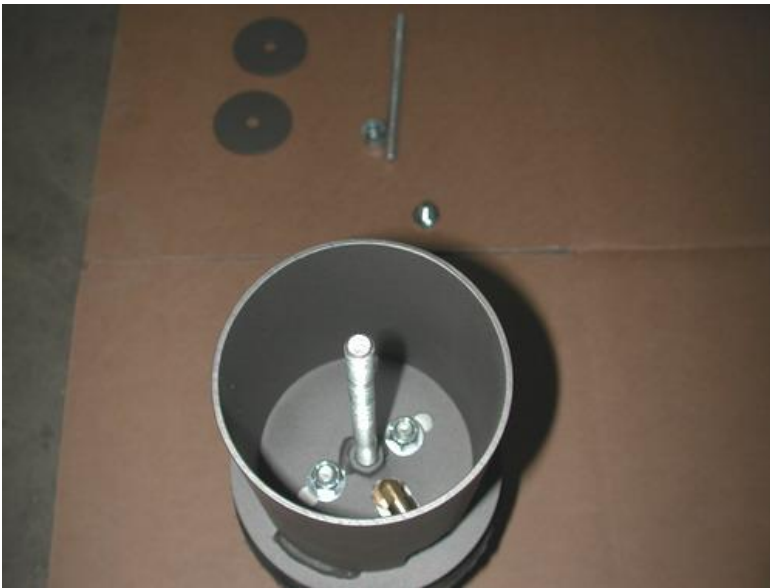

1. Apply thread sealant to an elbow air fitting and screw it into the top of the air spring.
2. Place the upper air spring bracket on top of the air spring clocked so the air fitting access hole is next to the fitting. Fasten it to the air spring using two 3/8" Nylok nuts and flat washers.
3. Screw the 7/16" x 6" all thread into the nut at the bottom of the bracket.



4. Place the upper washer on top of the coil spring pocket.



5. Raise the assembly into the coil spring pocket with the all thread sticking through the upper washer. Secure the assembly with a 7/16" Nylok nut and flat washer.



6. Fasten the air spring to the lower arm using a 3/8" x 3/4" bolt, flat washer and lock washer.

7. Double check air spring clearance through full suspension travel.

8. Ride height on this air spring is approximately 5" tall. This may vary to driver preference.



350 S. St. Charles St. Jasper, In. 47546
Ph. 812.482.2932 Fax 812.634.6632
www.ridetech.com

Part # 11280701
65-70 Impala HQ Series Rear Shock Kit

Shock:

2	22989999	HQ Smooth Body Shock Cartridge
2	70011139	5/8" ID Shock Bushing
2	70011138	3/4" ID Shock Bushing
2	90002103	5/8" ID Shock Sleeve
2	90002068	Wide Trunnion

Components:

2	90000471	Aluminum shock spacer
2	90001619	Shock stud

Hardware:

4	99311001	5/16" x 1" USS bolt	Shock to frame
8	99313002	5/16" SAE flat washer	Shock to frame
4	99312003	5/16" USS Nylok nut	Shock to frame



350 S. St. Charles St. Jasper, In. 47546
Ph. 812.482.2932 Fax 812.634.6632
www.ridetech.com

Part # 11280701
65-70 Impala HQ Series Rear Shock Kit

Shock:

2	22989999	HQ Smooth Body Shock Cartridge
2	70011139	5/8" ID Shock Bushing
2	70011138	3/4" ID Shock Bushing
2	90002103	5/8" ID Shock Sleeve
2	90002068	Wide Trunnion

Components:

2	90000471	Aluminum shock spacer
2	90001619	Shock stud

Hardware:

4	99311001	5/16" x 1" USS bolt	Shock to frame
8	99313002	5/16" SAE flat washer	Shock to frame
4	99312003	5/16" USS Nylok nut	Shock to frame

ridetech

350 S. St. Charles St. Jasper, In. 47546
Ph. 812.482.2932 Fax 812.634.6632
www.ridetech.com

Installation Instructions



1. Fasten the upper shock T-bar to the bottom of the frame using two 5/16" x 1" bolts, Nylok nuts and flat washers.

2. Use the new cantilever pin supplied to attach the bottom of the shock to the axle.



1. Cantilever Pin
2. 5/8" SAE Washer
3. Aluminum Bearing Spacer
4. .625" Bearing
5. Aluminum Bearing Spacer
6. Factory axle bracket
7. 1/2" Lock Washer
8. 1/2" SAE Nut

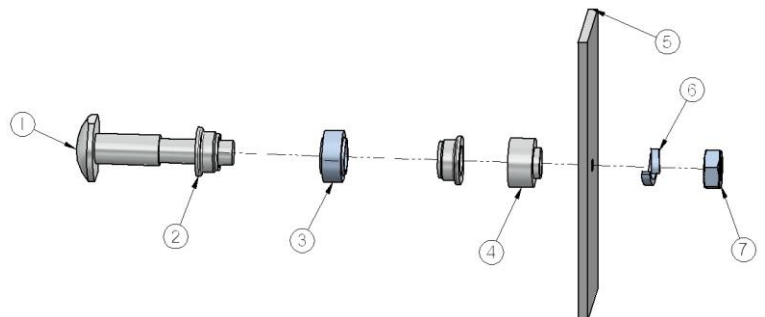



350 S. St. Charles St. Jasper, In. 47546
Ph. 812.482.2932 Fax 812.634.6632

www.ridetech.com

Part # 11284499
65-70 Impala Rear Lower StrongArms
For use w/ CoolRide

Components:

2	90001027	Lower arm – WW 22.5"
4	90001085	Poly bushing half
2	90001089	Poly bushing half (Rear)
2	90001086	Poly bushing half (Front)
2	90000722	Inner bushing sleeve - 2.625" long x .625" I.D x .75" O.D. (Rear)
2	90000467	Inner bushing sleeve - 2.5" long x .625" I.D. x .75" O.D. (Front)
2	90001092	Tube of Lithium grease

Hardware:

4	99621006	5/8" x 3 3/4" SAE Gr. 8 bolt	Upper and lower arms
4	99622006	5/8" SAE Nylok jam nut	Upper and lower arms/panhard bar stud

STRONG ARMS™

by Air Ride Technologies

Installation Instructions



1. Clean the bushing surfaces on the frame and axle brackets. Lubricate with the lithium grease supplied.
2. Fasten the StrongArm to the frame and axle using the 5/8" x 3 3/4" bolts and Nylok jam nuts supplied.
3. Fasten the air spring to the lower arm using a 3/8" x 3/4" bolt, flat washer and lock washer supplied w/ the air spring kit.



350 S. St. Charles St. Jasper, In. 47546
 Ph. 812.482.2932 Fax 812.634.6632

www.ridetech.com

Part # 11296699
65-66 Impala Rear Upper StrongArm & Panhard Bar Kit

Upper Arm Components:

1	90002580	Upper StrongArm – C-C 12.8125”
1	70013364	R-Joint Rod End housing
1	99752004	3/4”-16 SAE jam nut
4	70013544	R-Joint Spacer – 5/8” ID x 1.031” long

Panhard Bar Components:

1	90002827	Panhard bar – TW 33.875” (C-C 35.75”)
1	70013364	R-Joint Rod End housing
1	99752004	3/4”-16 SAE jam nut
1	90000461	Panhard bar axle stud
2	70013334	Axle Stud R-Joint Spacer – 5/8” ID x .620” long
2	70013764	Frame Mount R-Joint Spacers – 9/16” ID x .620” long

R-Joint Components

70013279	Retaining Ring
70013280	Wavo Wave Spring
70013276	R-Joint Composite Center Ball

Hardware:

2	99621006	5/8” x 3 3/4” SAE Gr. 8 bolt	Upper arm
3	99622006	5/8” SAE Nylok jam nut	Upper arm / panhard bar stud
1	99561003	9/16” x 3” SAE Gr. 8 bolt	Panhard bar to frame
2	99562001	9/16” SAE Nylok jam nut	Panhard bar
1	99563001	9/16” USS flat washer	Panhard bar stud
1	99603003	5/8” USS flat washer	Panhard bar stud

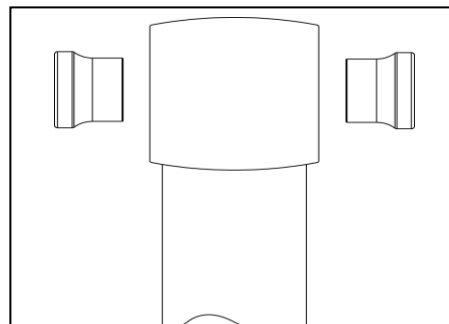

Insert the SMALL end of the spacer INTO each side of the center pivot ball. Push the spacer in until it bottoms out in the center pivot.

STRONG ARMS™

by Air Ride Technologies

Installation Instructions

New R-Joints will be quite stiff (75-90 in/lbs breakaway torque) until they "break in" after a few miles of use. After the break in period they will move much more freely. Because the composite bearing race contains self-lubricating ingredients, no additional lubrication is needed or desired. Any additional lubrication will only serve to attract more dirt and debris to the R-Joint and actually shorten its life.



1. Replace the factory upper trailing arm with the StrongArms. 5/8" x 3 3/4" bolts and Nylok jam nuts are supplied to replace the factory hardware. A 5/8" ID x 1.031" long spacer will need to be inserted into each side of the R-Joint.

Note: Some cars may have two upper arms. In this case you will need to order a second upper arm, part # 11296698



2. Replace the factory panhard bar with the new one using the new stud and hardware supplied. Insert the 5/8" Inside Diameter R-Joint Spacers into the R-joint of one end of the Panhard Bar.

Check air spring clearance through full suspension travel. Allowing the air spring to rub will result in failure and is not a warrantable situation.



3. The other end of the Panhard Bar will attach to the frame using the 9/16" x 3" bolt and Nylok nut. Insert the 9/16" Inside Diameter R-Joint Spacers into the R-joint

4. The panhard bar should be approximately 35 3/4" center eye to center eye, but may need adjusted to center the axle. This should be checked at ride height.



350 S. St. Charles St. Jasper, In. 47546
Ph. 812.482.2932 Fax 812.634.6632

www.ridetech.com

Part # 11289102
65-70 Impala Rear MuscleBar

Components:

1	90001782	Rear sway bar <i>(Includes the following)</i>
	2	1" I.D. Polyurethane bushings
	2	Bushing clamp
4	90000926	90 degree 10mm PosiLinks
1	90000738	Sway bar frame bracket
1	90000739	Sway bar frame bracket
2	90000740	Sway bar axle bracket
2	90000088	U Bolts 7/16" x 4 1/2" tall x 3 1/4" wide

Hardware:

3	99431002	7/16" x 1 1/4" USS bolt	Upper bracket
10	99432001	7/16" USS Nylok nut	U bolt / upper bracket
13	99433002	7/16" SAE flat washer	U bolt / upper bracket
2	99115001	10mm Posi Link studs	PosiLink (use Loctite)
4	99122001	10mm Nylok nut	PosiLink
8	99373003	3/8" SAE flat washer	PosiLink
2	90002275	Aluminum crush washer	PosiLink
2	90001092	Tube of lithium grease	

MUSCLEbar™

MUSCLEbar™

SWA8100 Installation Instructions

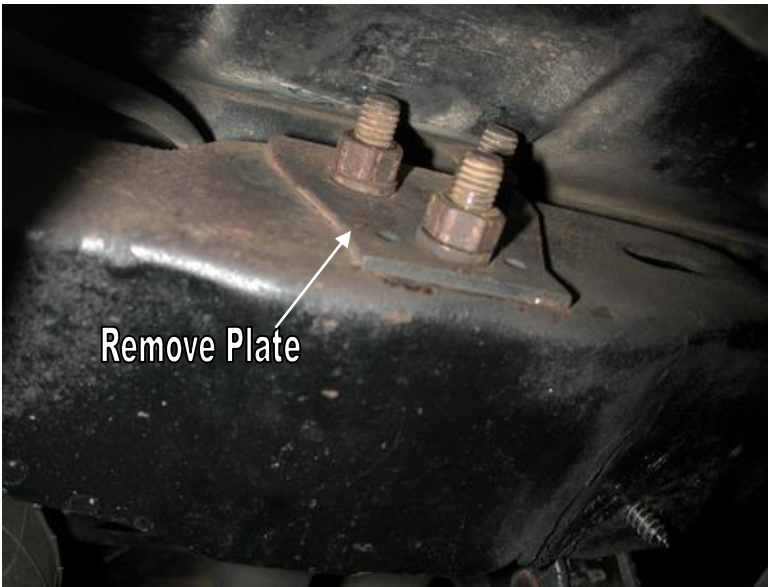

1. Loosen the 3 nuts holding the upper bar bracket to the cross member on the passenger side of the car. Remove the reinforcement plate.

2. Install the new sway bar frame mount using the 7/16" flat washer and Nylok nuts supplied. The tab for the PosiLink will face towards the outside of the vehicle, the image below shows the passenger side.



3. Most cars do not have an upper bar on the driver side, but the 3 bolt holes are there. 7/16" x 1 1/4" bolts, flat washers and Nylok nuts are supplied to fasten the bracket to the frame.

4. Fasten the PosiLink to the upper bracket using a 10mm Nylok nut. A 3/8" flat washer needs to be installed on each side of the bracket.

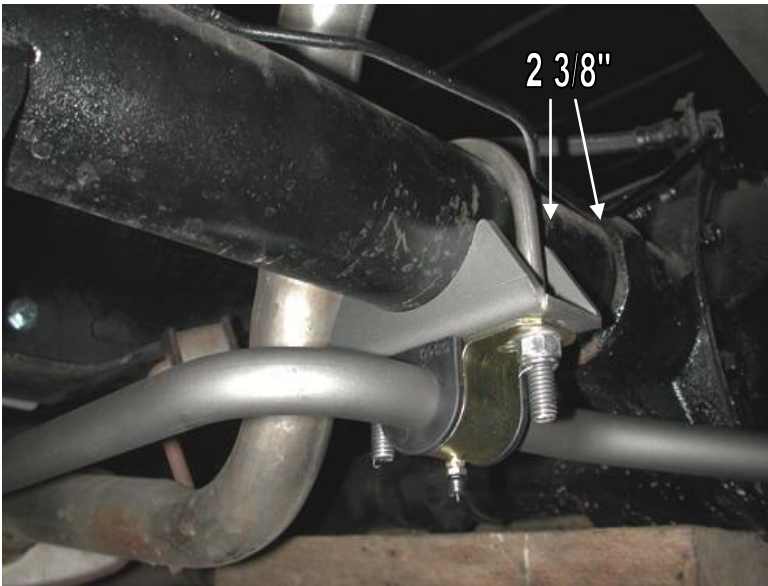

5. Attach the axle bracket, bushing and bushing bracket to the axle using the U bolt, 7/16" Nylok nut and flat washers supplied.

6. The inside edge of the axle bracket should be 2 3/8" from the center section. If you are using an aftermarket axle the brackets should be 21 7/8" apart, from inside to inside.

Note: Be sure not to put the bar on upside down. The back section of the bar should drop down to allow differential cover access.



7. Attach the sway bar to the PosiLink using a 10mm Nylok nut and two 3/8" flat washers.



8. Check MuscleBar clearance through full suspension travel.

Congratulations!!! Your new MuscleBar installation is now complete. If you have any further questions please call our tech support line. 812-482-2932