



350 S. St. Charles St. Jasper, In. 47546
Ph. 812.482.2932 Fax 812.634.6632

www.ridetech.com

Part # 11240298
68-72 GM "A" Body Air Suspension System

Front Components:

1	11243001	HQ Series Front Shockwaves
1	11222899	Front Lower StrongArms
1	11223699	Front Upper StrongArms
1	11009300	RideTech Tall Spindles
1	11249100	Front MuscleBar

Rear Components:

1	11225401	HQ Series Rear Shockwaves
1	11224499	Rear Lower StrongArms
1	11246699	Rear Upper StrongArms
1	11229102	Rear MuscleBar



Part # 11243001 - 68-72 GM A-Body Front HQ Series Shockwave

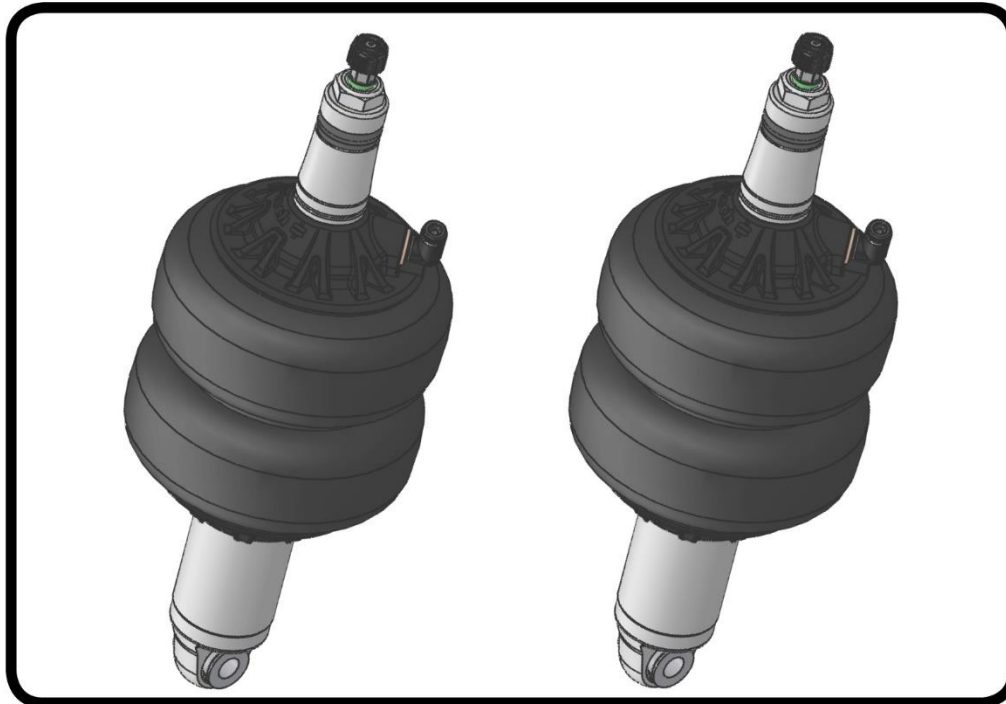

Recommended Tools



1000 Series Bellow, 2.75" Stud/Eye 3.6" Shock Installation Instructions

Table of contents

Page 2..... Included components

Page 3-4..... Shockwave Installation

Page 5-6..... Notes and Care of Your Shockwave & Shock Adjustment

ShockWave Dimensions:

Center of bearing to Center of bearing:

Compressed: 11.05"

Ride Height: 12.85"

Extended: 14.05"

THE DELRIN BALL REQUIRES A 3/4" HOLE FOR THE FLANGE TO GO THROUGH. THIS CAN BE DRILLED WITH A UNIBIT.

www.ridetech.com
812-482-2932





Major ComponentsIn the box

Item #	Part #	Description	QTY
1	24139999	3.6" Stroke HQ Series Shock	2
2	90009989	2.75" Stud Top (Installed on Shock) - Includes Adjuster Knob & Screw	2
3	24090199	1000 Series 6.5" Double Convoluted AirSpring	2
4	70010893	AirSpring Locking Ring (Installed on shock)	2
5	99055000	Locking Ring Set Screw (Installed on shock)	2
6	90002062	Spacers - INCLUDED WITH STRONGARMS	4
7	90002313	2.75" Aluminum Stud Top Base	2
8	90001904	Bottom Delrin Ball	2
9	90001903	Top Delrin Ball	2
10	90001902	Delrin Ball Aluminum Top Cap	2
11	99562003	9/16" -18 Thin Nylok Nut	2
12	90009972	Adjuster Knob - (90009989 assembly)	2
13	90009969	#4-40 X 1/4" SS, 18-8 Pan Head Torx Cap - (90009989 assembly)	2
	70012161	2.75" Stud Top Metering Rod (installed in stud top)	2
	90001994	5/8" ID Bearing (installed in shock and eyelet)	4
	90001995	Bearing Snap Ring (installed in shock and eyelet)	8

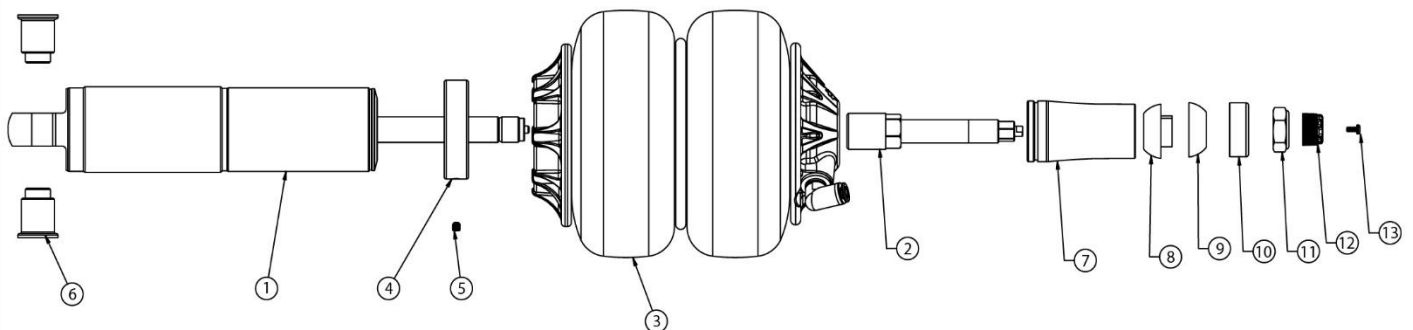

THE DELRIN BALL REQUIRES A 3/4" HOLE FOR THE FLANGE TO GO THROUGH. THIS CAN BE DRILLED WITH A UNIBIT.

WARNING: ATTEMPTING TO REMOVE THE AIR FITTING WILL DAMAGE IT AND VOID THE WARRANTY.



ShockWave Installation

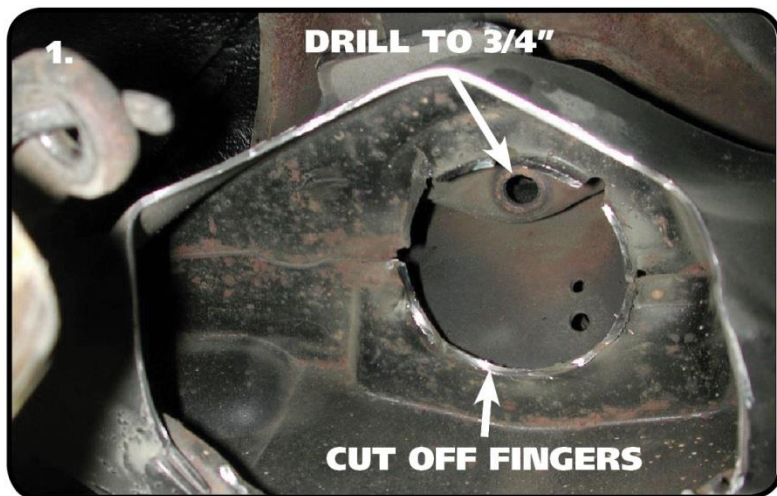

1. Drill the OEM shock hole out to 3/4". This can be done with a Unibit. The Shockwave top can come in contact with the coil spring retaining fingers. Test fit the ShockWave to determine if they need cut off. A die grinder works well here.



2. Some trimming must also be done on the outside of the frame pocket to allow clearance for the Shockwave.

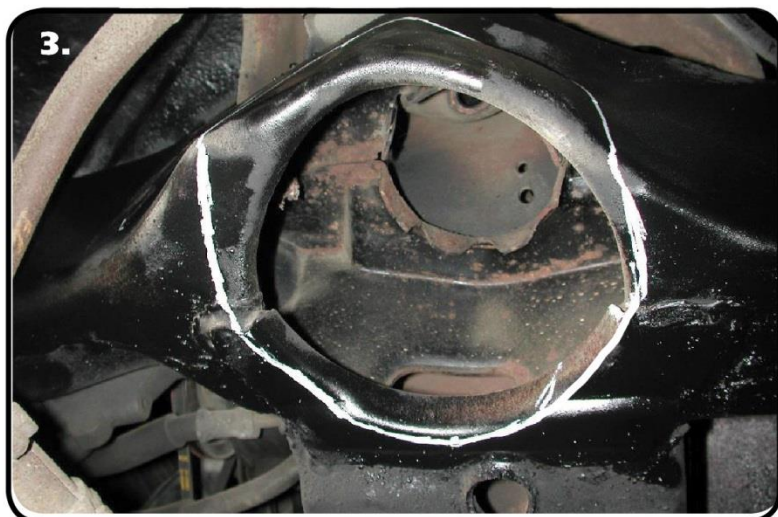

3. To allow clearance for the Shockwave, some trimming must be done on the inside of the coil spring pocket as shown by the white line in the picture. This is best done with either a cut off wheel or plasma cutter. Grind all cuts smooth when finished.

Note: It may be helpful to go ahead and install the lower StrongArms and Shockwaves to determine exactly what needs to be removed.



ShockWave Installation

4.

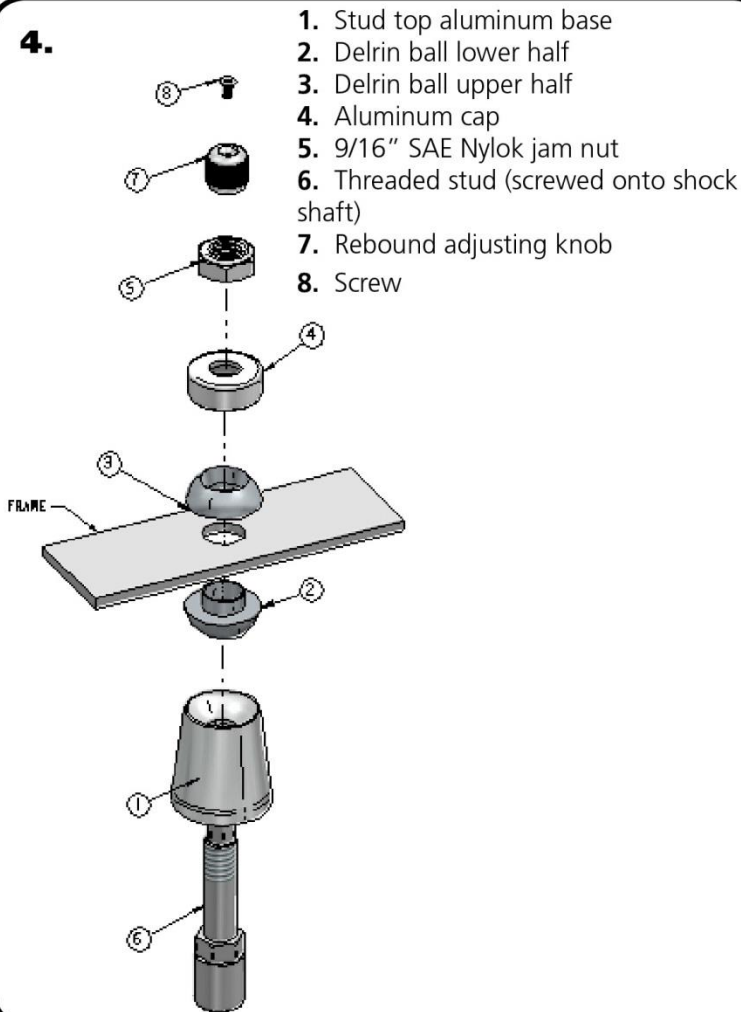

Note: The airline must also be routed at this time. It can be ran through the subframe toward the rear of the vehicle.

4. The air fitting location can be rotated by twisting the bellow assembly separate of the shock. Place the Shockwave into the coil spring pocket with the stud sticking through the OEM shock hole. See assembly **Diagram 4**. OEM Shock hole **must** be drilled out to $\frac{3}{4}$ "

1. Stud top aluminum base
2. Delrin ball lower half
3. Delrin ball upper half
4. Aluminum cap
5. 9/16" SAE Nylok jam nut
6. Threaded stud (screwed onto shock shaft)
7. Rebound adjusting knob
8. Screw

5.

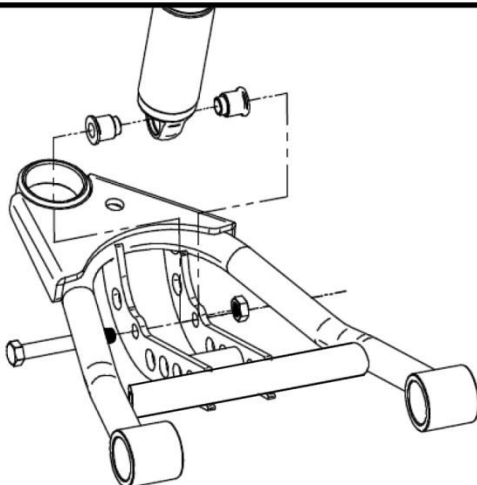

5. Raise the lower arm up to the Shockwave and bolt them together using the $\frac{1}{2}$ " x $3\frac{1}{4}$ " bolt and Nylok supplied w/ the lower arms. An aluminum spacer will be on each side of the bearing. Torque to 75 ftbs.

6. Raise the lower control arm to full compression and double-check to make sure the Shockwave does not rub on anything at any-time. Allowing the Shockwave to rub on anything will cause failure and is not a warrantable situation.

7. The best ride quality will occur around 50-60% suspension travel; depending on vehicle weight this typically occurs around 85-100 psi.



Notes and Care of your Shockwaves

NOTES:

WARNING: ATTEMPTING TO REMOVE THE AIR FITTING WILL DAMAGE IT AND VOID THE WARRANTY.

TIGHTENING THE TOP 9/16"-18 NUT: SNUG THE NUT DOWN AGAINST THE TOP CAP. YOU NEED TO BE ABLE TO ARTICULATE THE SHOCK BY HAND.

You can clock the airfitting location on the ShockWave by turning the AirSpring assembly of the shock. Make sure the fitting doesn't contact the frame.

When cutting the airline, use a razor blade. The cut needs to be a clean cut and square for the airline to seal properly.

The Locking ring on the shock is **NOT** adjustable. These rings are set at the factory to optimize the AirSpring stroke with the shock stroke.

The care and feeding of your new ShockWaves

1. Although the ShockWave has an internal bumpstop, **DO NOT DRIVE THE VEHICLE DEFLATED RESTING ON THIS BUMPSTOP. DAMAGE WILL RESULT.** The internal bumpstop will be damaged, the shock bushings will be damaged, and the vehicle shock mounting points may be damaged to the point of failure. This is a non warrantable situation.
2. Do not drive the vehicle overinflated or "topped out". Over a period of time the shock valving will be damaged, possibly to the point of failure. This is a non warrantable situation! If you need to raise your vehicle higher than the ShockWave allows, you will need a longer unit.
3. The ShockWave is designed to give a great ride quality and to raise and lower the vehicle. **IT IS NOT MADE TO HOP OR JUMP!** If you want to hop or jump, hydraulics are a better choice. This abuse will result in bent piston rods, broken shock mounts, and destroyed bushings. This is a non warrantable situation.
4. Do not let the ShockWave bellows rub on anything. Failure will result. This is a non warrantable situation.
5. The ShockWave product has been field tested on numerous vehicles as well as subjected to many different stress tests to ensure that there are no leakage or durability problems. Failures have been nearly nonexistent unless abused as described above. If the Shockwave units are installed properly and are not abused, they will last many, many years. ShockWave units that are returned with broken mounts, bent piston rods, destroyed bumpstops or bushings, or abrasions on the bellows will not be warrantied.



Part # 11222899 - 1964-1972 GM A-Body Front Lower StrongArms



Recommended Tools



1964-1972 GM A-Body Lower StrongArms Installation Instructions

Table of contents

- Page 2..... Lower Control Arm Components
- Page 3..... Getting Started & Installation
- Page 4..... Installing Spindles and Steering Stop





Lower Control Arm ComponentsIn the box

Item #	Part Number	Description	QTY
1	90001224	Driver Lower Control Arm (Shown)	1
1	90001225	Passenger Lower Control Arm	1
2	90000898	Lower Balljoint Assembly	2
3	70010759	Delrin Bushing - with 2" Diameter Ledge	8
4	90002062	CoilOver Bearing Spacers	4
5	90000516	1/2" ID Inner Sleeve	4
6	99501014	1/2"-20 x 3 1/2" Hex Bolt	6
7	99502002	1/2"-20 Nylok Nut	6
8	99503014	1/2" SAE Flat Washer	6
9	99371005	3/8"-16 x 1 1/4" Hex Bolt	2
10	99372012	3/8"-16 Hex Nut	2

Driver Side Shown

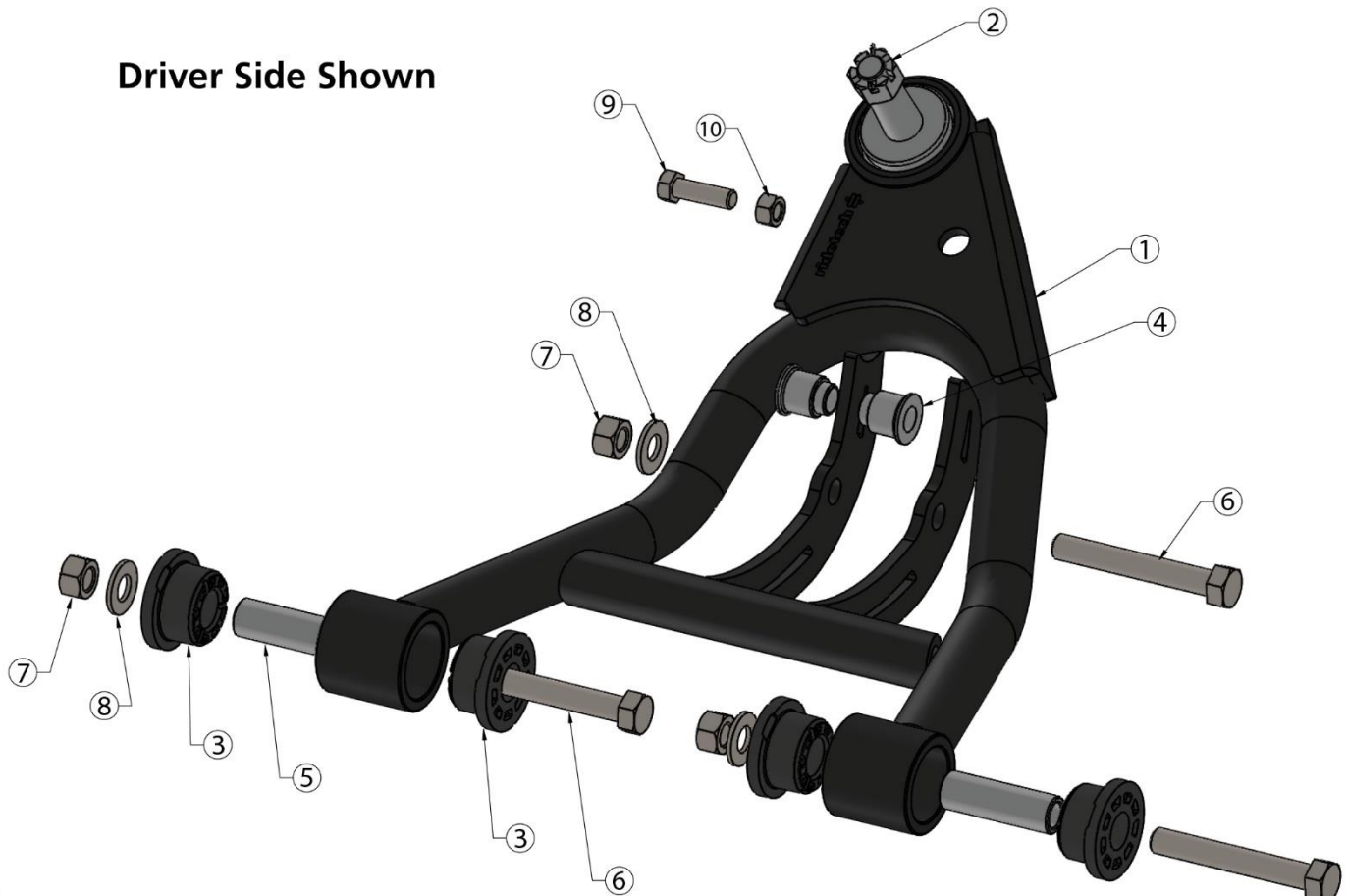



Getting Started.....

Congratulations on your purchase of the Ridetech A-Body StrongArms. These StrongArms have been designed to give your A-Body excellent handling along with a lifetime of enjoyment. Some of the key features of the TruTurn System: Balljoint angles have been optimized for the lowered ride height, Delrin bushings are used to eliminate bushing deflection along with providing free suspension movement through the entire travel. The Geometry has been optimized for excellent handling, driveability and minimal bumpsteer. The Delrin bushings are made from a material that is self lubricating so no grease zerks are needed.

Note: These control arms are designed for use with the Ridetech CoilOvers and the MuscleBar swaybar. **The factory shocks and springs or the factory sway bar will not fit these arms.**

Installation

1. Remove the entire lower control arms from the car. If you are replacing the upper control arms and spindle, remove them too. Refer to a Factory Service Manual for the proper method.
2. Drill the factory upper shock mounting hole to 3/4". This can be done easily with a Unibit.

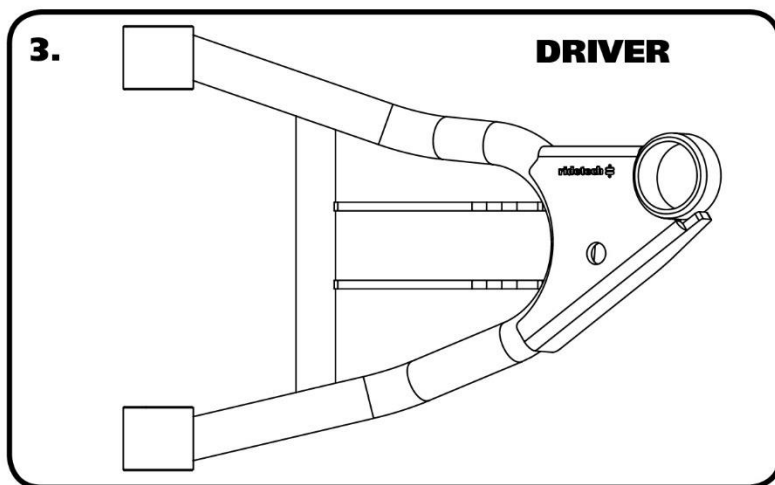

3. After removing the factory lower control arm, clean the bushing mounting surfaces on the frame. The Control Arms are marked "D" for Driver and "P" for Passenger. The Balljoint Pin points up and the Sway bar mount is on the front side of the arm. Fasten the lower arm to the frame with the hardware supplied. Note: On some cars the frame brackets may be pinched and will need to be spread back apart to allow the bushing to slide in.

Install the CoilOvers at this time. Refer to the CoilOver instructions for Assembly.

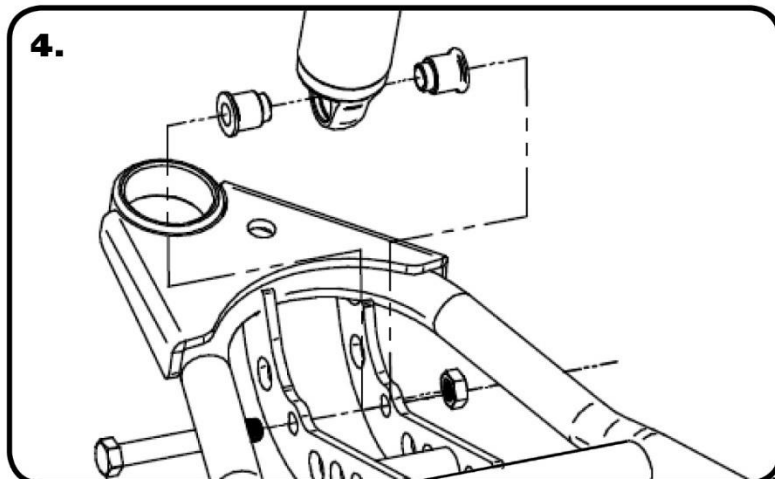

4. Insert the Bearing Spacers into the lower shock bearing. The SMALL end goes into the bearing. Swing the Control Arm up, line up the 1/2" holes with the bearing spacers, insert 1/2"-20 x 3 1/2" bolt. Install a 1/2" flat washer and nylok nut.



Installing Spindle & Setting Steering Stop

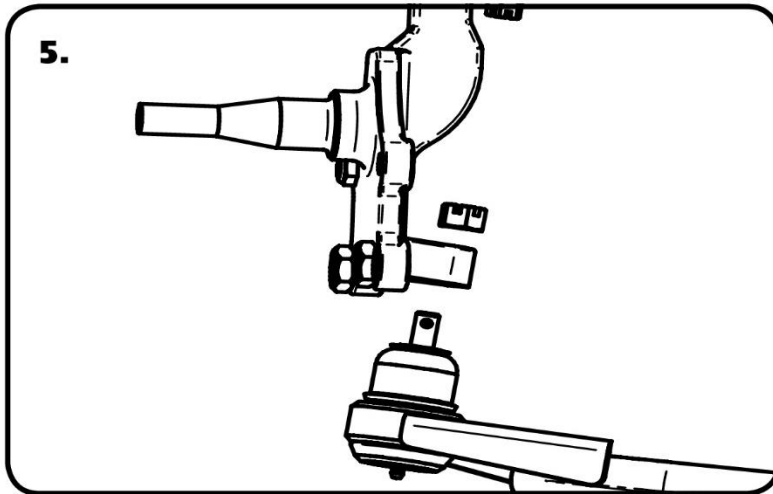

5. Attach the Spindle to the control arms.

Torque Specs:

Lower Balljoint - 65 ftlbs and tighten to line up cotter pin.

Install the Cotter Pin after tightening the ball joint nut.



5. Thread the 3/8"-16 nut onto the 3/8"-16 x 1 1/4" bolt. Thread it into the front hole of the ball joint plate. You will need to adjust the steering stop to suite your needs. This setting will vary depending on wheel and tire size and other suspension components.

6. Tighten all fasteners. If you are going to install the Ridetech MuscleBar, now is a good time to do it.

Suggested Alignment Specs:

Camber: Street: -.5 degrees
Caster: Street: +3.0 to + 5.0 degrees
Toe: Street: 1/16" to 1/8" toe in



Part # 11223699 - 1964-1972 GM A-Body Front Upper StrongArms



Recommended Tools



1964-1972 GM A-Body Upper StrongArms Installation Instructions

Table of contents

- Page 2..... Upper Control Arm Components
- Page 3..... Getting Started
- Page 4..... Caster Explained
- Page 5..... Offset Upper Control Arm Crossshaft
- Page 6..... Installing Spindle and Alignment





Upper Control Arm ComponentsIn the box

Item #	Part Number	Description	QTY
1	90001222	Driver Upper Control Arm (Shown)	1
1	90001223	Passenger Upper Control Arm	1
2	90000938 kit	Upper Ball Joint Kit	2
3	90000914 kit	Caster Slug Crossshaft Kit	2
4	70010883	Caster Slug	4
5	70010759	Outer Delrin Bushing with 2" Lip	4
6	70010827	Inner Delrin Bushing with 1.75" Lip	2
7	70010826	Inner Delrin Bushing with No Lip	2
8	90002734	Aluminum T-Washer	4
9	99253008	1/4" SAE Flat Washer	8
10		5/8" -18 Jam Lock Nut - Included with 90000914 kit	4
11	99433004	7/16" USS Flat Washer - NOT SHOWN	4

Driver Side Shown

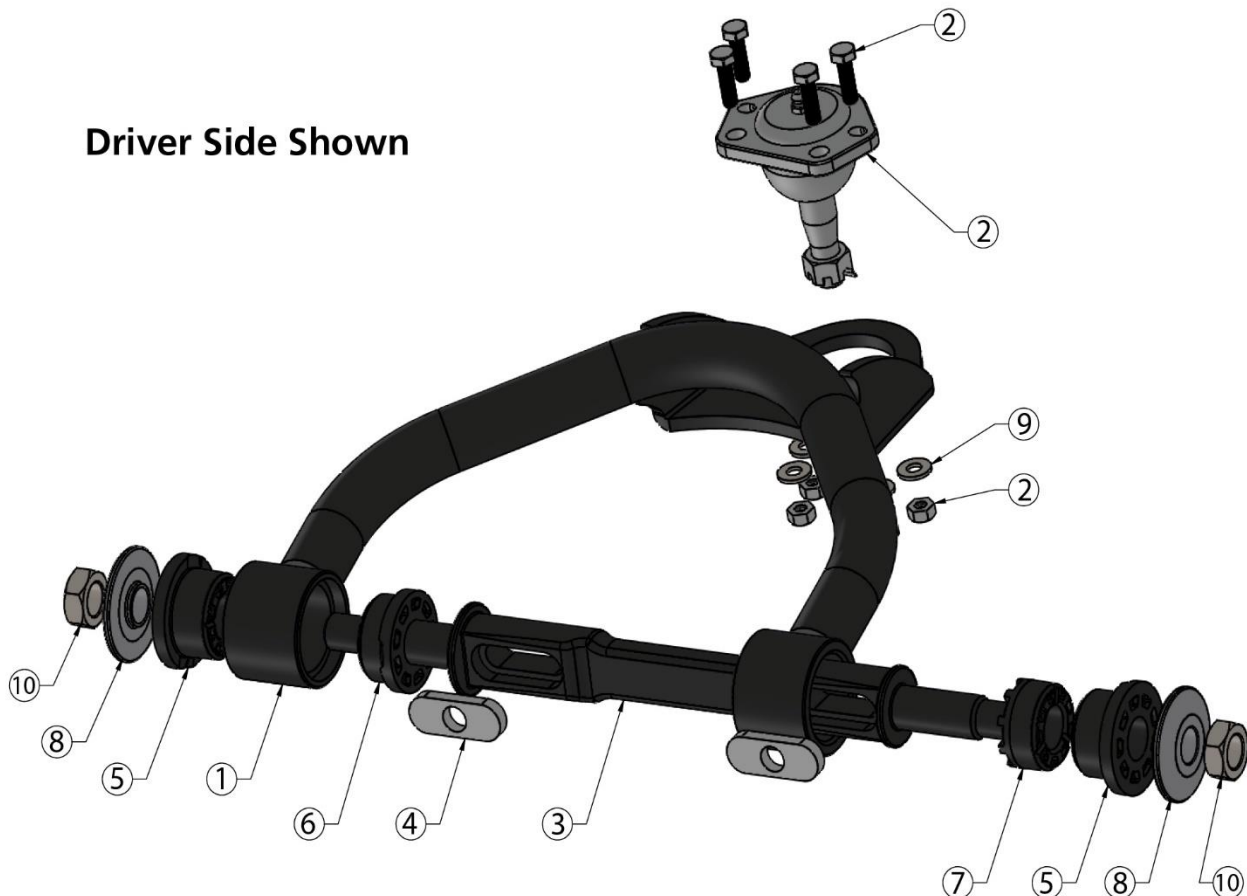



Getting Started.....

Congratulations on your purchase of the Ridetech A-Body StrongArms. These StrongArms have been designed to give your A-Body excellent handling along with a lifetime of enjoyment. Some of the key features of the TruTurn System: Balljoint angles have been optimized for the lowered ride height, Delrin bushings are used to eliminate bushing deflection along with providing free suspension movement through the entire travel. The Geometry has been optimized for excellent handling, driveability and minimal bumpsteer. The Delrin bushings are made from a material that is self lubricating so no grease zerks are needed.

When assembling the Control Arms tighten the cross shaft nuts enough to create drag on the delrin bushings, the arm should still move through its travel by hand.

Installation

1. Remove the entire upper control arms from the car. If you are replacing the lower control arms and spindle, remove them too. Refer to a Factory Service Manual for the proper method.

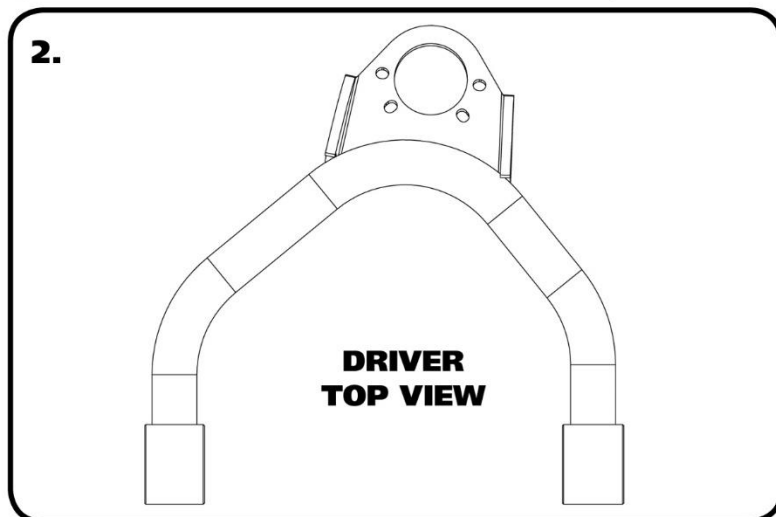

2. The Upper Control Arm is attaching the factory mount using factory hardware. The driver side arm is shown in **Figure "2"**. The Balljoint located on the arm to the front of the car.



3. The Upper Control Arm is attaching the factory mount using factory hardware with the supplied 7/16" Flat Washer under the OEM Nut. The driver side arm is shown in Figure "3". The Arrow on the Cross shaft points to the front of the car. Page 4 & 5 has information about Caster and the Caster Slugs.



Caster Explained

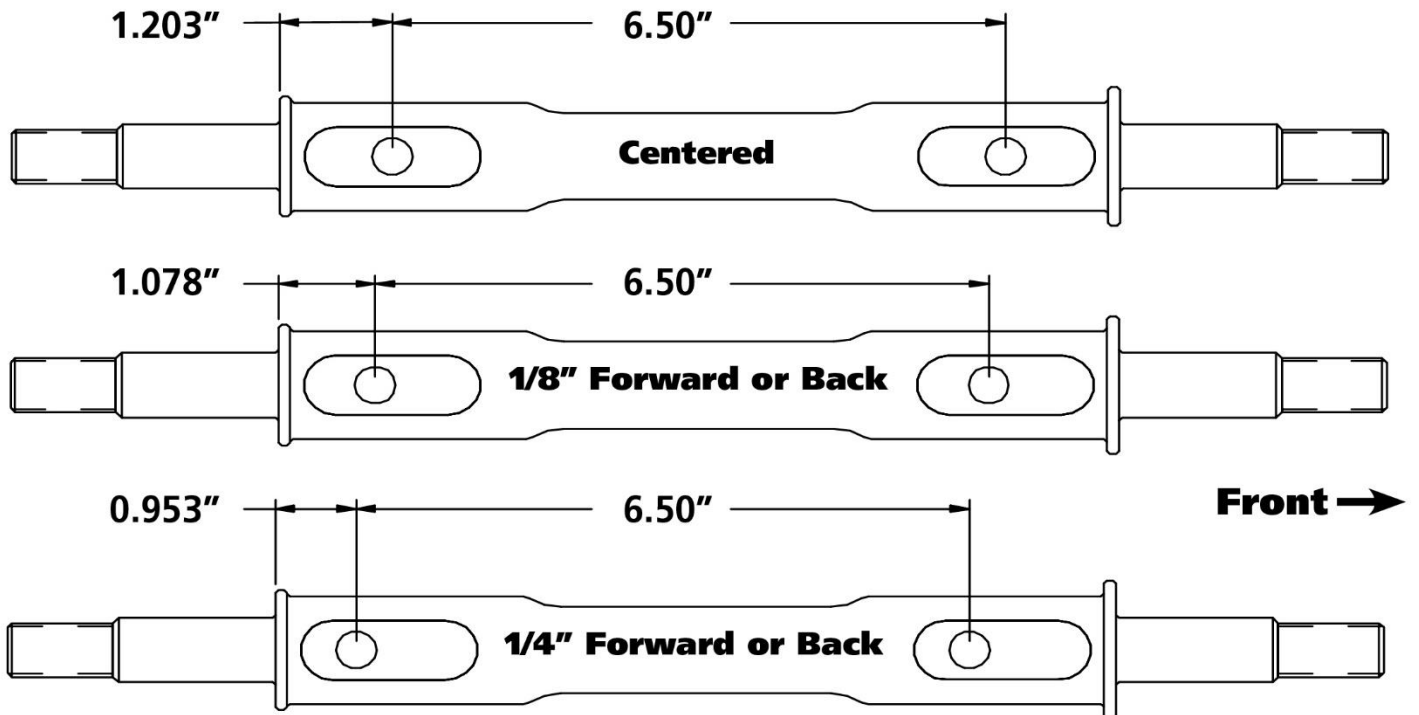

These StrongArms come equipped with a changeable caster slug setup. This allows you to add or remove caster from the front suspension, if desired. The caster slugs that come supplied in the kit are setup to be centered or 1/8" back. The caster slugs allow you to add or remove caster without having to use a stack of shims. If more or less caster is desired, optional slugs can be purchased from Ridetech or your Ridetech dealer.

Caster Explained:

To understand caster you need to picture an imaginary line that runs through the upper balljoint and extends through the lower balljoint. From the side view the imaginary line will tilt forward or backward. The tilting of this imaginary line is defined as caster.

Caster is measured in degrees by using a caster gauge. If the imaginary line described above tilts towards the back of the vehicle at the top, then you have positive caster. If the imaginary line tilts forward then you have negative caster.

Positive caster provides the directional stability in your vehicle. Too much positive caster will make the steering effort difficult. Power steering will allow you to run more positive caster. Negative caster requires less steering effort but will cause the vehicle to wander down the highway



Offset Upper Control Arm Shaft

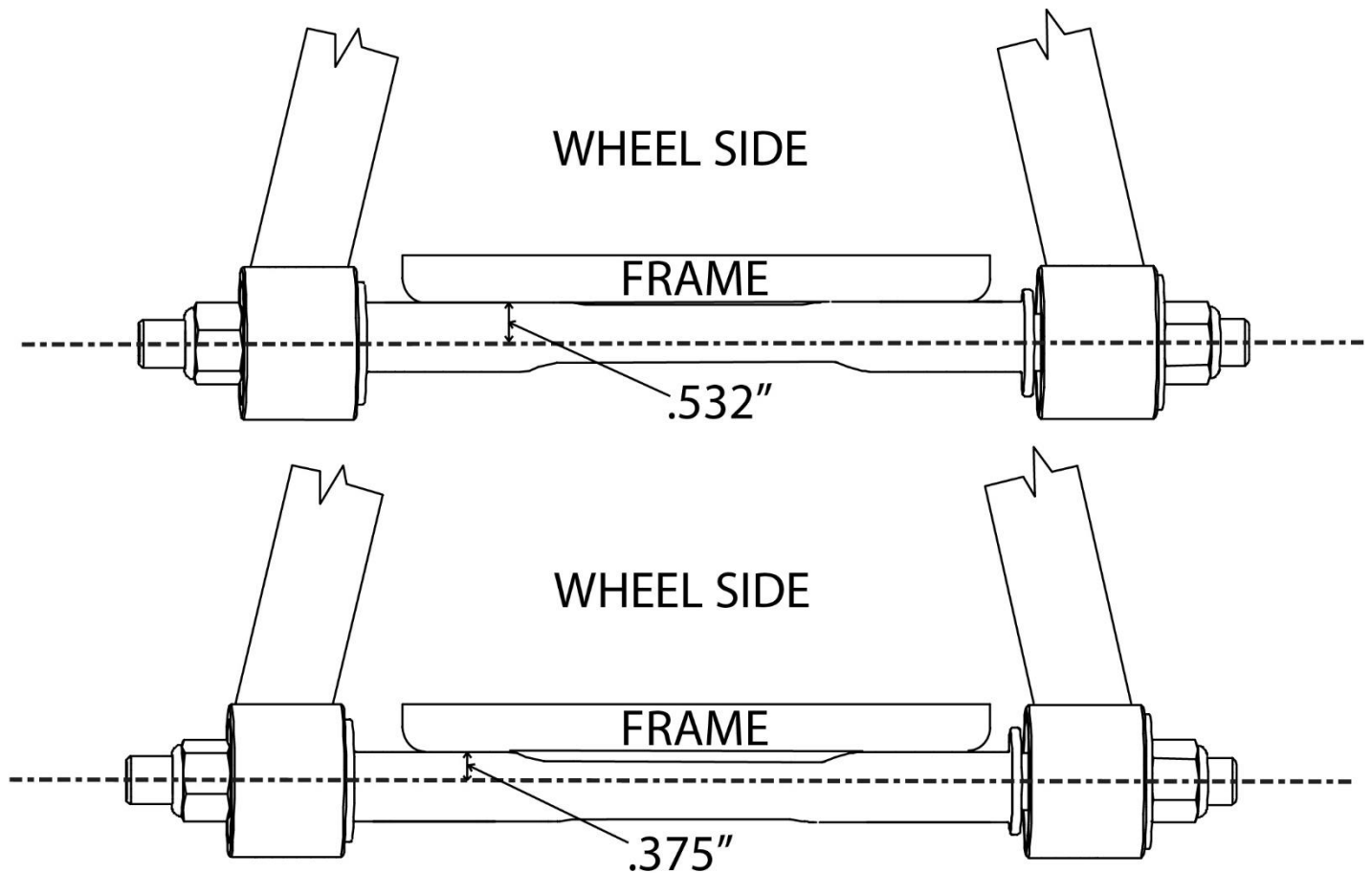

The cross shaft that is used in the upper control arms is offset. The offset combined with the caster slug option allows you to achieve the alignment setting you desire with minimal shims. To change the direction the Icon faces simply spin the cross shaft in the control arm.

If you are after a **Street Alignment** bolt the upper control arm to the frame mount with the arm offset to the outside of the car. The Ridetech Icon and Caster Slugs will be facing the wheel.

If a more aggressive **Track or Autocross** alignment is desired, bolt the control arm to the frame bracket with the arm offset to the inside of the car. The Ridetech Icon and Caster Slugs will be facing the engine.



Installing Spindle and Alignment

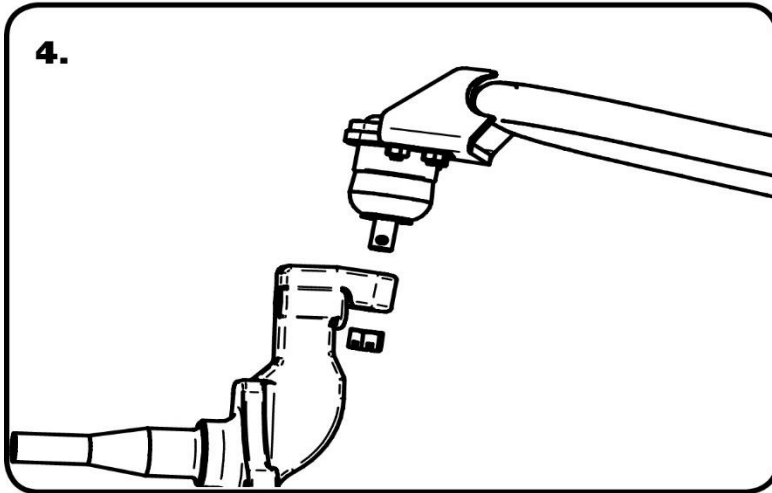

4. Attach the Spindle to the control arms.

Torque Specs:

Upper Balljoint - 50 ftlbs and tighten to line up cotter pin.

Install the Cotter Pin after tightening the ball joint nut.

5. Tighten all fasteners.

When assembling the Control Arms tighten the cross shaft nuts enough to create drag on the delrin bushings, the arm should still move through its travel by hand.

Suggested Alignment Specs:

Camber:	Street: -.5 degrees
Caster:	Street: +3.0 to + 5.0 degrees
Toe:	Street: 1/16" to 1/8" toe in



350 S. St. Charles St. Jasper, In. 47546
Ph. 812.482.2932 Fax 812.634.6632

www.ridetech.com

11009300 GM "A" & "F" Body Tall Spindles

2 Tall Spindles

Hardware:

Lower steering arm bolts

(4) 1/2NFX 2 1/2" flathead socket head bolts with Nyloc nuts

Lower caliper bracket bolts

(2) 1/2NFX 2" flathead socket head bolts with Nyloc nuts (Wilwood and Baer Brake kits)

(2) 1/2NFX 2" Grade 8 hex head bolts (use with stock stamped 1/2" thick caliper brackets)

INSTRUCTIONS FOR Ridetech Tall SPINDLES

These spindles will fit '67-69 Camaro, '64-'72 Chevelle, and '68-'74 Nova. They will provide a 2" drop, and are taller than stock to improve the car's cornering ability. The raised upper ball joint will cause the tires to lean into the corner, like a motorcycle, rather than outboard as the shorter stock spindles do. This camber action change also raises the roll center for less body roll, and transfer the car's center of gravity inboard in the turn as well. You will see an appreciable improvement in handling. Standard size anti sway bars will work well with those improvements, without the need for monster sway bars that can cause a harsh ride.

The spindles are modeled after stock disc brake spindles and will accept any disc brake set up designed for those. If your car came with drum brakes, be sure to swap to the appropriate disc brake master cylinder and valving. We have test fitted ECI, Wilwood, Baer, Aerospace, and stock GM kits. The only modification we discovered to be necessary was a small trim on the bottom of the stamped ¼" steel caliper bracket that holds the caliper. It is an area that is not stressed and will not cause any loss of strength. There are variations among the various reproduction the shaft to be flipped in it's bushings for brackets, so the trim will be seen only on some of those.

Stock stamped control arms will accept these spindles, as will any aftermarket arms we have seen. Our own tubular control arms have the upper ball joint plates rotated slightly for better ball joint angles on lowered cars. We also set the ball joint ¾" to the rear of the car to allow more aggressive positive caster settings, as well as to compensate for the normal forward rake seen on hot rods. The upper control arms shaft has a 3/16" offset, allowing the shaft to be rotated in it's bushings for a 3/8" net change in the upper arm's effective length. That design was pioneered by the MOOG company, as many stock autos suffer from a sagged cross member, making it difficult to obtain good alignment numbers. We suggest the alignment be done with 1/8" toe in, ½ degree negative camber, and at least 3 degrees positive caster with power steering, 2 degrees manual.

It is important to be sure you have the proper steering arms. Many cars were updated to disc brakes in the past by using disc brake and spindle assemblies from a donor car. However, the Chevelle steering arms are front steer, and the tie rod is roughly the same height as the lower ball joint. The Camaro and Nova arms are rear steer, with the outer tie rod end much lower than the ball joint. If the incorrect arms are used, the incorrect height tie rod end will cause major bump steer problems. Our testing of prototype versions of these spindles revealed that a small additional lowering of the mounting holes for the steering arms was necessary to remove the small amount of factory bumpsteer, and to account for the changes made by the taller spindle. We included that enhancement in the production version of your new dropped spindles.



Disassembly of the ball joints from the spindles can be eased by making the simple tool shown in the photo below. A pair of 1 ½" long bolts are threaded into a matching hex coupler. The ball joint cotter pins are removed, and the hex nuts loosened a couple turns. Place the tool between the ball joint studs, and turn a bolt to expand the tool, gently popping the ball joint studs loose. If your ball joint boots are torn, as often happens when a pickle fork is used to separate the ball joints, NAPA has replacements. The best way to remove the outer tie rod pivot is to loosen the hex nut, and then rap the steering arm boss with a hammer. Tie rod ends pullers are also available if you want to be more gentle on the parts. Do NOT hammer on the tie rod stud itself! Be sure to leave the shock absorber in place to control the spring and prevent it jumping out.

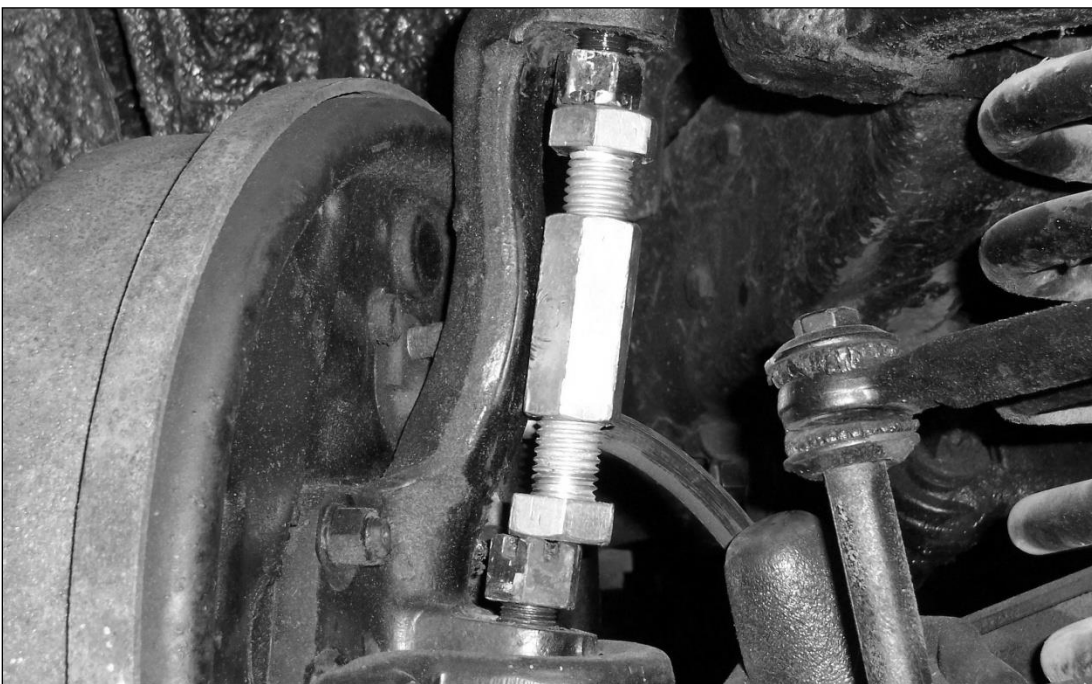

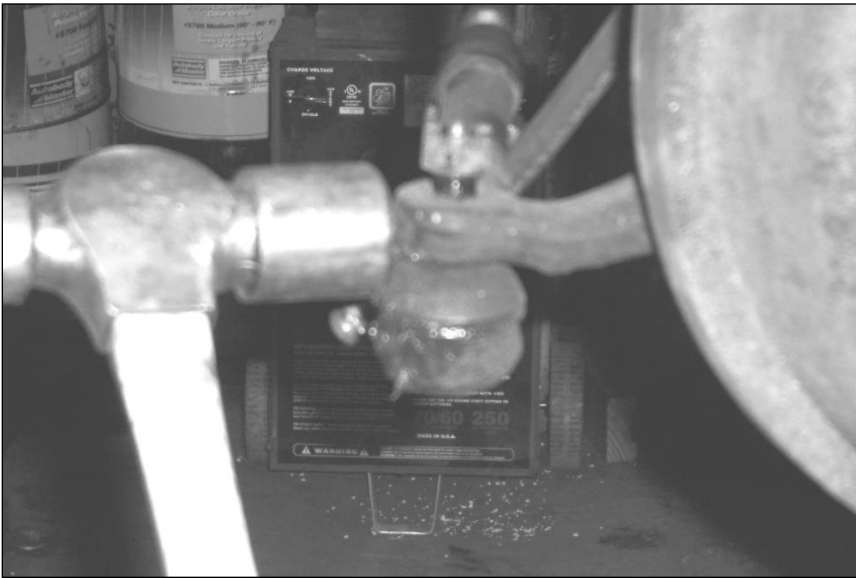

If you remove the calipers but leave the hoses attached, supporting them to avoid stressing the hoses, you won't even need to rebleed the brakes!

Reattach the new spindle, being sure to get the castle nuts tight, and install new cotter pins. Attach the steering arms into the lower holes in the spindles using the 4 supplied 1/2NFx2 1/2" long flathead bolts and nylok nuts supplied. The 1/2NFx 2" long flat head bolts and nylok nuts we supply are for use with Wilwood and Baer brake kit lower bracket bolts. The 1/2NFx2" hex head bolts are used with stock caliper brackets. Reassemble your disc brakes as well. Now would be a good time to clean and grease the bearings.

BEFORE you try moving the car, pump the brakes to reset the pads to the rotors. Rebleed if necessary. Have the alignment shop set the car with 1/2 degree negative camber, 3-5 degrees positive caster, and 1/16"-1/8" toe in. We're sure you'll be amazed at the difference in handling!



Note: If using a factory style stamped caliper bracket, the bracket may need to be trimmed. The dust shield may also need to be modified.



350 S. St. Charles St. Jasper, In. 47546
Ph. 812.482.2932 Fax 812.634.6632

www.ridetech.com

Part # 11249100
68-72 GM "A" Body Front MuscleBar

Components:

1	90000151	Front sway bar (38.750" Tube length)
1	90000148	Driver side arm
1	90000149	Passenger side arm
1	90000146	Driver side frame plate
1	90000147	Passenger side frame plate
1	90000153	Driver side frame bracket
1	90000154	Passenger side frame bracket
2	90000926	90 degree 10mm PosiLink
2	90000924	Straight 10mm PosiLink
4	90000717	T-bushing (PosiLink to lower arm)
2	90001099	Polyurethane frame bushing – 1.5" I.D.
2	99250001	¼-28 straight grease zerk
1	90001092	Tube of Lithium grease
2	99115001	10mm x 1.5 x 36mm stud (use Loctite) In PosiLink

Hardware Kit: 99010041

2	99371028	3/8" x 3/4" USS Flat head Allen bolt	Frame plate to frame
4	99371004	3/8" x 1 ¼" USS bolt	Frame bracket
14	99373003	3/8" SAE flat washer	Frame bracket / Sway bar arm to bar
10	99373005	3/8" lock washer	Frame bracket / Sway bar arm to bar
6	99371017	3/8" x 1" Button head Allen bolt	Sway bar arm to bar
4	99112002	10mm Nylok nut	PosiLink
2	99502003	½" SAE Nyloc jam nut	Steering arm

MUSCLEbar™

by Air Ride Technologies

11249100 Installation Instructions

1. This sway bar was designed for use with our lower StrongArms. Installation with other control arms may require modification.
2. Remove the end links from the factory sway bar. Then remove the bolts attaching the sway bar to the frame.

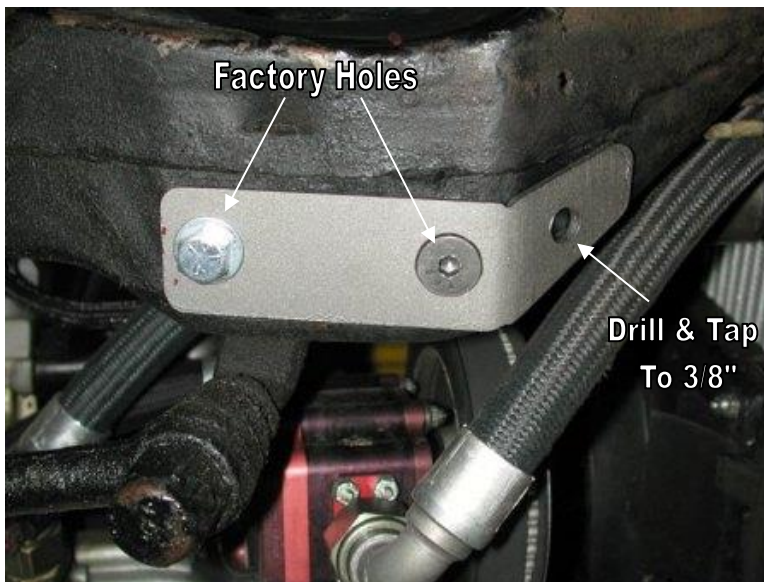

3. Bolt the frame plate to the frame using the factory sway bar holes. The front hole will use a 3/8" x 3/4" flat head Allen screw. The rear hole will use a standard 3/8" x 1 1/4" hex bolt.

4. Using the bracket as a guide, drill the front hole with a 5/16" bit and thread with a 3/8"-16 tap.

Note: On some cars the factory bolt holes may be 5/16" and will need to be drilled and tapped to accept a 3/8" bolt.



5. Slide the poly bushing over the bar and lubricate with the lithium grease supplied.

6. Slide the bracket over the bushing and fasten the bar to the frame using 3/8" x 1 1/4" bolts, flat washers and lock washers.

Note: Future lubrication should only be done with non-petroleum based lubricants.

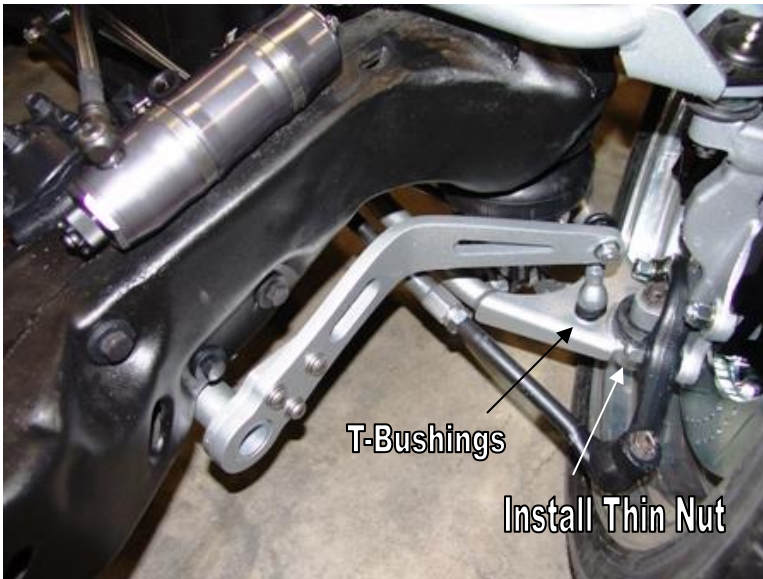

7. Bolt the sway bar arm to the bar using 3/8" x 1" Button head screws with flat washers and lock washers.

8. Fasten the 90 degree end of the PosiLink to the sway bar arm using a 3/8" flat washer on each side of the arm and a 10mm Nylok nut.

9. Two T-bushing will be used on each side to attach the straight end of the PosiLink to the lower control arm. Secure with a 10mm Nylok nut.

10. Install the thin 1/2" Nylok nuts on the front bolt of the steering arm, and cut off excess threads.

11. Check PosiLink alignment through full suspension travel to ensure that it does not bind.





Part # 11225401 - 1964-1972 GM A-Body Rear Shockwave

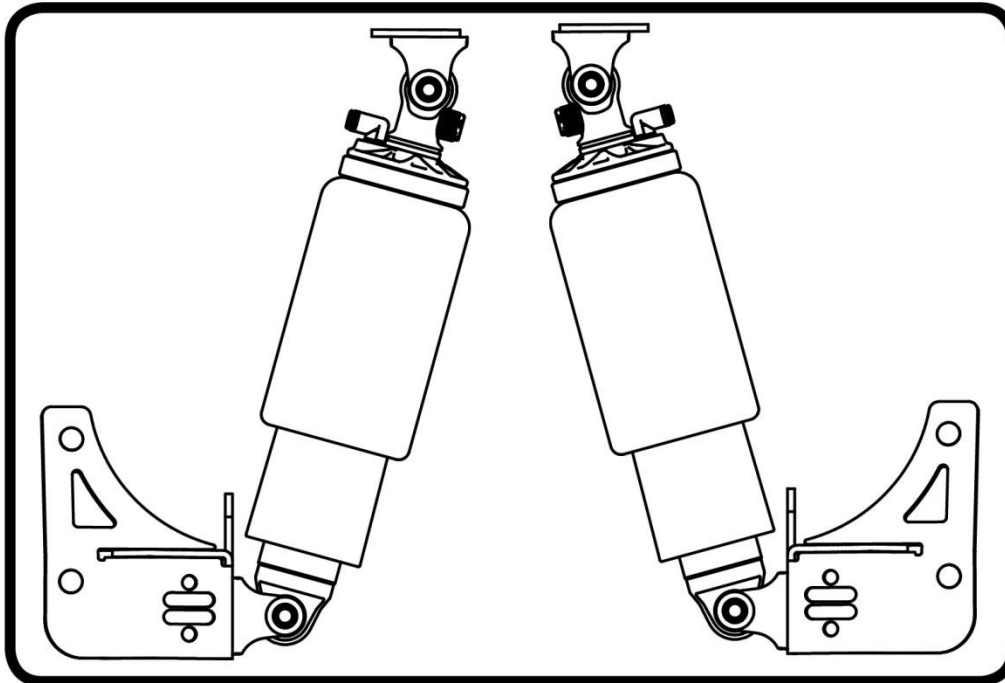

Recommended Tools



64-72 A-Body HQ Series Rear Shockwave Installation Instructions

Table of contents

- Page 2..... Included components
- Page 3..... Hardware List and Getting Started
- Page 4..... ShockWave installation
- Page 5..... ShockWave Installation and Notes and Care
- Page 6..... Care of your Shockwaves
- Page 7..... Shock Adjustment

www.ridetech.com
812-482-2932





Major ComponentsIn the box

Item #	Part #	Description	QTY
1	24159999	5.2" Stroke HQ Series Shock	2
2	24090799	7000 Series 4" Diameter Air Spring	2
3	90002024	Shock Eyelet	2
4	90001994	5/8" ID Bearing (installed in shock and eyelet)	4
5	90001995	Bearing Snap Ring (installed in shock and eyelet)	8
6	90002043	1/2" ID Upper Bearing Spacers	8
7	90002327	Upper Mount	2
8	90002224	Driver Lower Mount	1
8	90002223	Passenger Lower Mount (not shown)	1
	70008313	Air Spring Locking Ring (not shown)	2
	99055000	Air Spring Locking Ring Set Screw (not shown)	2

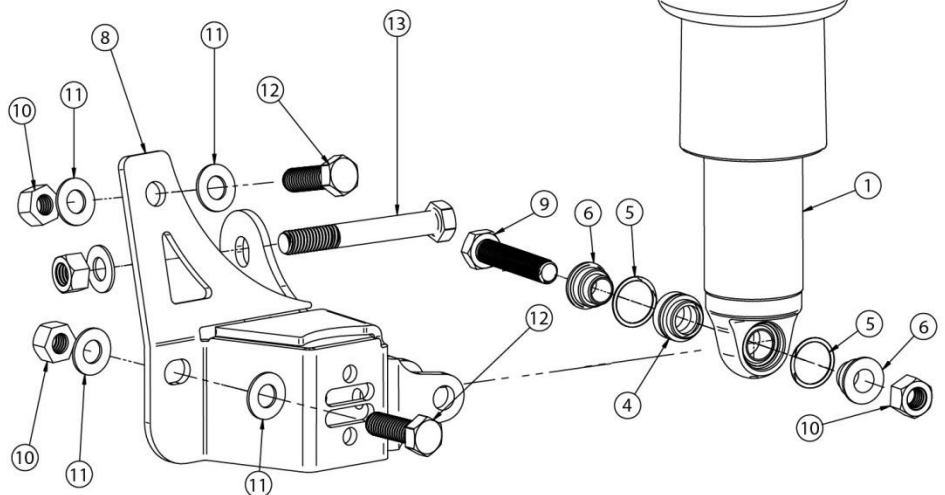
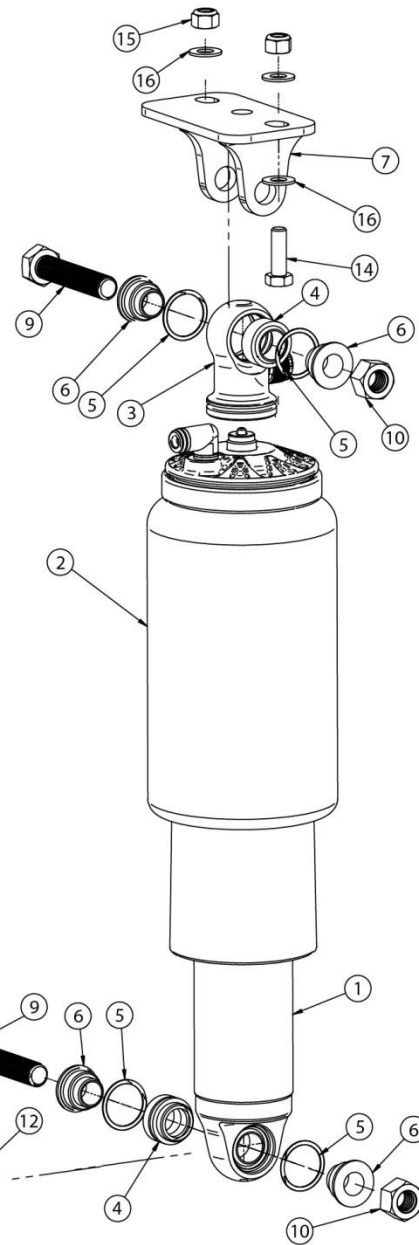

WARNING: ATTEMPTING TO REMOVE THE AIR FITTING WILL DAMAGE IT AND VOID THE WARRANTY.



Hardware ListIn the box

Item #	QTY	Part Number	Description	Location
9	4	99501011	1/2"-20 x 2 1/2" Hex Bolt	ShockWave to Mounts
10	10	99502002	1/2"-20 Nylok Nut	ShockWave to Mounts, Lower Bar Bolt
11	14	99503014	1/2" SAE Flat Washer	ShockWave to Mounts, Lower Bar Bolt
12	4	99501008	1/2"-20 x 1 1/2" Hex Bolt	Lower Mounts to Differential
13	2	99501015	1/2"-20 x 3 3/4" Hex Bolt	Lower Bar Bolt
14	4	99311011	5/16"-18 x 1 1/4" Hex Bolt	Upper Mounts to Frame
15	4	99312002	5/16"-18 Nylok Nut	Upper Mounts to Frame
16	8	99313001	5/16" SAE Flat Washer	Upper Mounts to Frame

Getting Started.....

Congratulations on your purchase of the Ridetech Rear Shockwave System. This system has been designed to give your car excellent handling along with a lifetime of enjoyment. One of the key features of this system is the adjustability. With the ShockWave system you have an adjustable shock along with the height adjustment of the air spring.

Disassembly

1. Raise and safely support the vehicle by the frame rails.
2. Using a jack, slightly raise the axle approximately 1". Remove the shock absorbers.
3. Lower the axle down enough to remove the coil springs.
4. The exhaust tail pipes may need to be removed and/or modified for ShockWave installation.

NOTE: Keep in mind the spring has pressure on it until you let the rear differential down to remove the springs.



ShockWave Installation

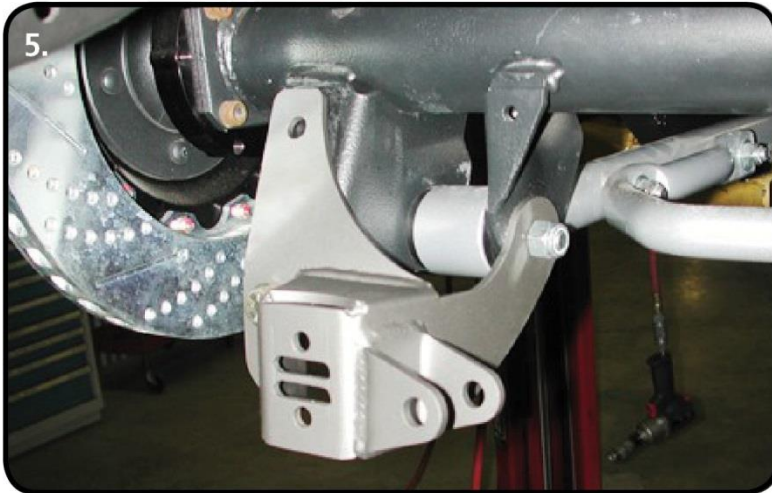

5. Remove the lower trailing arm mounting bolt. (Do one side at a time to keep the axle from rotating). Install the longer $\frac{1}{2}$ " x $3\frac{3}{4}$ " bolt through the lower trailing arm from the outside in. Install the lower bracket over the bolt and secure with a $\frac{1}{2}$ " Nylok nut and flat washer. Snug the Hardware, but do NOT fully tighten at this time.

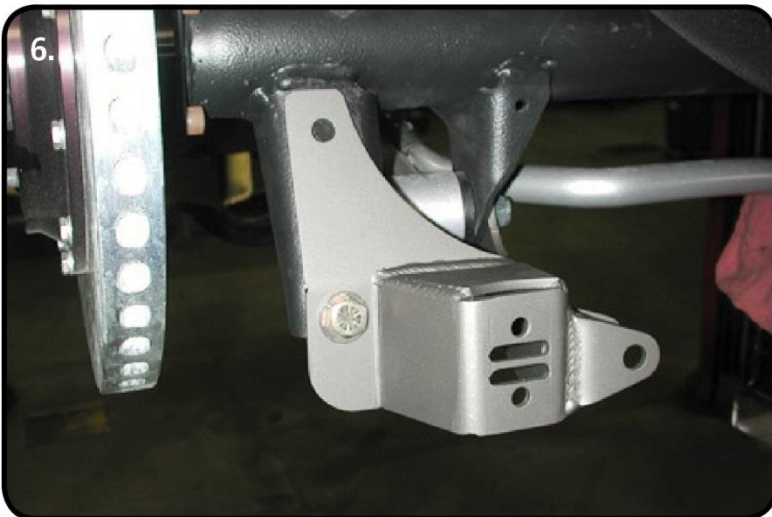

6. The lower bolt hole in the back of the bracket will align with the factory shock stud hole. Use a $\frac{1}{2}$ " x $1\frac{1}{2}$ " bolt, Nylok nut and flat washers. The upper hole must be drilled with a $\frac{1}{2}$ " bit. The edge of the bracket should be parallel to the axle bracket. Use an centering punch and $\frac{1}{8}$ " bit to drill a pilot hole. A $\frac{1}{2}$ " x $1\frac{1}{2}$ " bolt, Nylok nut and flat washers will be used here as well. Torque all hardware to 75 ftlbs.



7. Fasten the new upper shock bracket into the factory shock location using the $\frac{5}{16}$ " x 1" bolts, flat washers and Nylok nuts supplied. Torque to 17 ftlbs.

Note: Position the bracket to offset the shock toward the center of the car.



ShockWave Installation

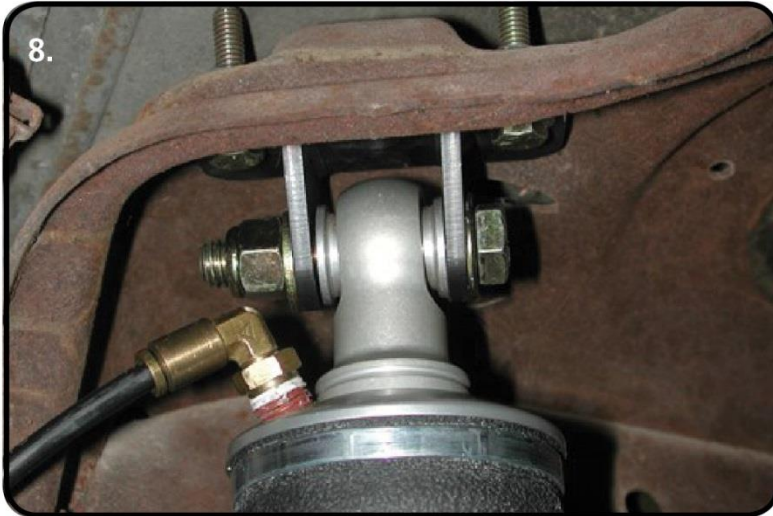

8. Fasten the ShockWave to the upper bracket using a 1/2" x 2 1/2" bolt and Nylok nut. 1/2" I.D. aluminum spacers must be installed on each side of the bearing. Torque to 75 ftlbs.

Note: The air fitting location can be rotated by twisting the bellow separate of the shock.

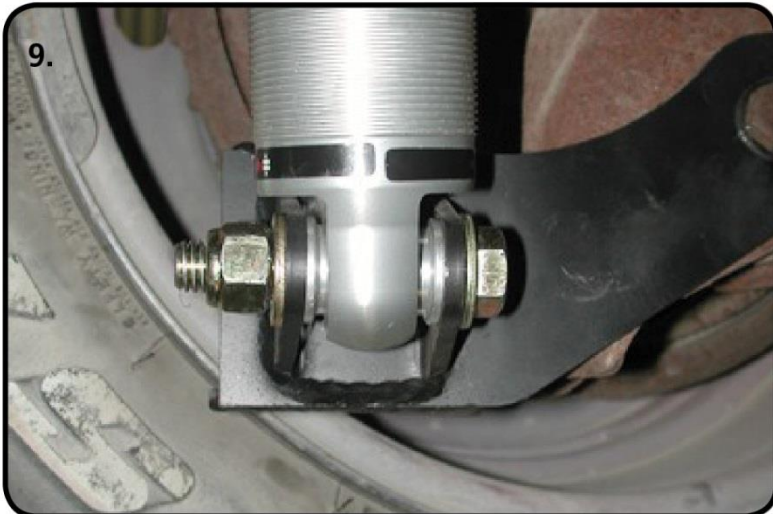

9. Fasten the ShockWave to the lower bracket using a 1/2" x 2 1/2" bolt and Nylok nut. 1/2" I.D. aluminum spacers must be installed on each side of the bearing. Torque to 75 ftlbs.

10. Double check air spring clearances throughout full suspension travel.

11. Ride height on this ShockWave is 14.5" from center eye to center eye. This should occur around 70-80psi, but may vary to vehicle weight and driver preference

Notes and Care of your Shockwaves

NOTES:

WARNING: ATTEMPTING TO REMOVE THE AIR FITTING WILL DAMAGE IT AND VOID THE WARRANTY.

You can clock the airfitting location on the ShockWave by turning the AirSpring assembly of the shock. Make sure the fitting doesn't contact the frame.

When cutting the airline, use a razor blade. The cut needs to be a clean cut and square for the airline to seal properly.

The Locking ring on the shock is **NOT** adjustable. These rings are set at the factory to optimize the AirSpring stroke with the shock stroke.



Care of your ShockWaves

The care and feeding of your new ShockWaves

1. Although the ShockWave has an internal bumpstop, **DO NOT DRIVE THE VEHICLE DEFLATED RESTING ON THIS BUMPSTOP. DAMAGE WILL RESULT.** The internal bumpstop will be damaged, the shock bushings will be damaged, and the vehicle shock mounting points may be damaged to the point of failure. This is a non warrantable situation.
2. Do not drive the vehicle overinflated or “topped out”. Over a period of time the shock valving will be damaged, possibly to the point of failure. This is a non warrantable situation! If you need to raise your vehicle higher than the ShockWave allows, you will need a longer unit.
3. The ShockWave is designed to give a great ride quality and to raise and lower the vehicle. **IT IS NOT MADE TO HOP OR JUMP!** If you want to hop or jump, hydraulics are a better choice. This abuse will result in bent piston rods, broken shock mounts, and destroyed bushings. This is a non warrantable situation.
4. Do not let the ShockWave bellows rub on anything. Failure will result. This is a non warrantable situation.
5. The ShockWave product has been field tested on numerous vehicles as well as subjected to many different stress tests to ensure that there are no leakage or durability problems. Failures have been nearly nonexistent unless abused as described above. If the Shockwave units are installed properly and are not abused, they will last many, many years. ShockWave units that are returned with broken mounts, bent piston rods, destroyed bumpstops or bushings, or abrasions on the bellows will not be warrantied.



Shock Adjustment

Shock adjustment 101- Single Adjustable

Rebound Adjustment:

How to adjust your new shocks.

The rebound adjustment knob is located on the top of the shock absorber protruding from the eyelet.

You must first begin at the ZERO setting, then set the shock to a soft setting of 20.



-Begin with the shocks adjusted to the ZERO rebound position (full stiff). Do this by rotating the rebound adjuster knob clockwise until it stops.



-Now turn the rebound adjuster knob counter clock wise 20 clicks. This sets the shock at 20. (settings 21-24 are typically too soft for street use).

Take the vehicle for a test drive.



-if you are satisfied with the ride quality, do not do anything, you are set!

-if the ride quality is too soft increase the damping effect by rotating the rebound knob clock wise 3 clicks. **CONTINUE ON NEXT PAGE.**

Take the vehicle for another test drive.



-if the vehicle is too soft increase the damping effect by rotating the rebound knob clock wise 3 additional clicks.



-If the vehicle is too stiff rotate the rebound adjustment knob counter clock wise 2 clicks and you are set!

Take the vehicle for another test drive and repeat the above steps until the ride quality is satisfactory.

Note:

One end of the vehicle will likely reach the desired setting before the other end. If this happens stop adjusting the satisfied end and keep adjusting the unsatisfied end until the overall ride quality is satisfactory.

STILL HAVE QUESTIONS?

Tech line hours

Monday - Friday

8AM - 6PM (EST) 812-482-2932



350 S. St. Charles St. Jasper, In. 47546
Ph. 812.482.2932 Fax 812.634.6632

www.ridetech.com

Part # 11246699
68-72 GM "A" Body Rear Upper StrongArms

Components:

- 2 90001115 Upper StrongArm (Set to 10.26")
- 2 70013364 R-Joint threaded rod end housing
- 4 70013784 R-Joint Spacers

R-Joint Components

- 70013279 Retaining Ring
- 70013280 Wavo Wave Spring
- 70013276 R-Joint Composite Center Ball Cage
- 70013275 R-Joint Stainless Center Ball

Hardware:

- 2 99752004 3/4" SAE Jam nut R-Joint End
- 4 99501005 1/2"-20 x 3 1/2" Gr. 8 bolt StrongArms
- 4 99502009 1/2"-20 Gr. 8 Nut StrongArms

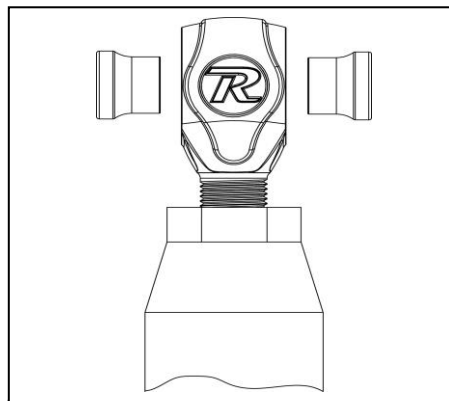

Insert the SMALL end of the spacer INTO each side of the center pivot ball. Push the spacer in until it bottoms out in the center pivot.

STRONG ARMS™

by Air Ride Technologies

Installation Instructions

New R-Joints will be quite stiff (75-90 in/lbs breakaway torque) until they "break in" after a few miles of use. After the break in period they will move much more freely. Because the composite bearing race contains self-lubricating ingredients, no additional lubrication is needed or desired. Any additional lubrication will only serve to attract more dirt and debris to the R-Joint and actually shorten its life.



1. The length of the upper bar should be set from the factory at 10.26" center to center. Ensure that the jam nut is tight.
2. Insert the Spacers into the R-Joints. Refer to Diagram 1 on Page 1.
3. Using the 1/2" x 3 1/2" bolt and Nylok nut supplied, fasten the R-Joint end to the frame bracket. An aluminum spacer must be installed on each side of the Heim end.



4. Fasten the other end of the bar to the axle using a 1/2" x 3 1/2" bolt and Nylok nut.

Note: Inspect the rubber bushing in the axle for wear or cracked. Replace with factory replacement bushing if needed.



350 S. St. Charles St. Jasper, In. 47546
Ph. 812.482.2932 Fax 812.634.6632

www.ridetech.com

Part # 11224499
64-72 GM "A" Body Rear Lower StrongArms

Components:

- 2 90002826 Lower StrongArm – WW 22"
- 8 70013784 R-Joint Spacers

R-Joint Components

- 70013279 Retaining Ring
- 70013280 Wavo Wave Spring
- 70013276 R-Joint Composite Center Ball Cage
- 70013275 R-Joint Stainless Center Ball

Hardware:

- 2 99501014 ½"-20 x 3 ½" Gr. 8 bolt StrongArms to frame
- 2 99502002 ½"-20 Gr. 8 Nylok nut StrongArms to frame

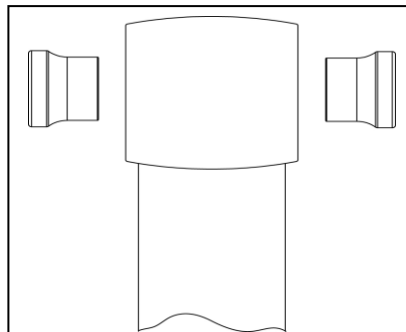

Insert the SMALL end of the spacer INTO each side of the center pivot ball. Push the spacer in until it bottoms out in the center pivot.

STRONG ARMS™

by Air Ride Technologies

Installation Instructions



1. Remove the sway bar (if equipped) and factory lower trailing arm. Do one side at a time to keep the axle from rotating.
2. Insert the Spacers into the R-Joints. Refer to Diagram 1 on Page 1.
3. Attach to front on the lower StrongArm to the frame using the $\frac{1}{2}$ " x $3\frac{1}{2}$ " bolts and Nylok nuts supplied.
4. This arm has holes in the tube for sway bar attachment. Mount the bar so that the holes are closest to the axle. New $\frac{7}{16}$ " x 3" bolts are supplied to reattach the sway bar.



5. Attach to rear of the lower StrongArm to the frame using the $\frac{1}{2}$ " x $3\frac{1}{2}$ " bolts and Nylok nuts supplied.

Note: Tighten the bolts enough to remove any lateral movement.

New R-Joints will be quite stiff (75-90 in/lbs breakaway torque) until they "break in" after a few miles of use. After the break in period they will move much more freely. Because the composite bearing race contains self-lubricating ingredients, no additional lubrication is needed or desired. Any additional lubrication will only serve to attract more dirt and debris to the R-Joint and actually shorten its life.



350 S. St. Charles St. Jasper, In. 47546

Ph. 812.482.2932 Fax 812.634.6632

www.ridetech.com

Part # 11229102
64-72 GM "A" Body Rear MuscleBar

Components:

1 90009960 Rear sway bar

Hardware:

4 99431003 7/16" x 3" bolt Sway bar to lower arm

4 99432001 7/16" Nylok nut Sway bar to lower arm

8 99433002 7/16" flat washer Sway bar to lower arm

MUSCLEbarTM
by Air Ride Technologies

Installation Instructions



1. Attach sway bar to lower trailing arms using 7/16" x 3" bolts, Nylok nuts and flat washers supplied.
2. If using factory trailing arm without sway bar mounting holes, they will need to be drilled. Use the sway bar as a template; it is self positioning as the lower arms are angled. Spacers are supplied to keep from pinching the arm.