



350 S. St. Charles St. Jasper, In. 47546
Ph. 812.482.2932 Fax 812.634.6632

www.ridetech.com

Part # 11260298
68-72 GM "X" Body Air Suspension System

Front Components:

1	11163001	HQ Series Front Shockwaves
1	11162899	Front Lower StrongArms
1	11163699	Front Upper StrongArms
1	11009300	RideTech Tall Spindles
1	11169100	Front MuscleBar

Rear Components:

1	11267199	Rear AirBar – Bolt-on 4 Link
1	21150701	Rear HQ Series Shockwaves



Part # 11163001 - 67-69 GM F-Body Front HQ Series Shockwave

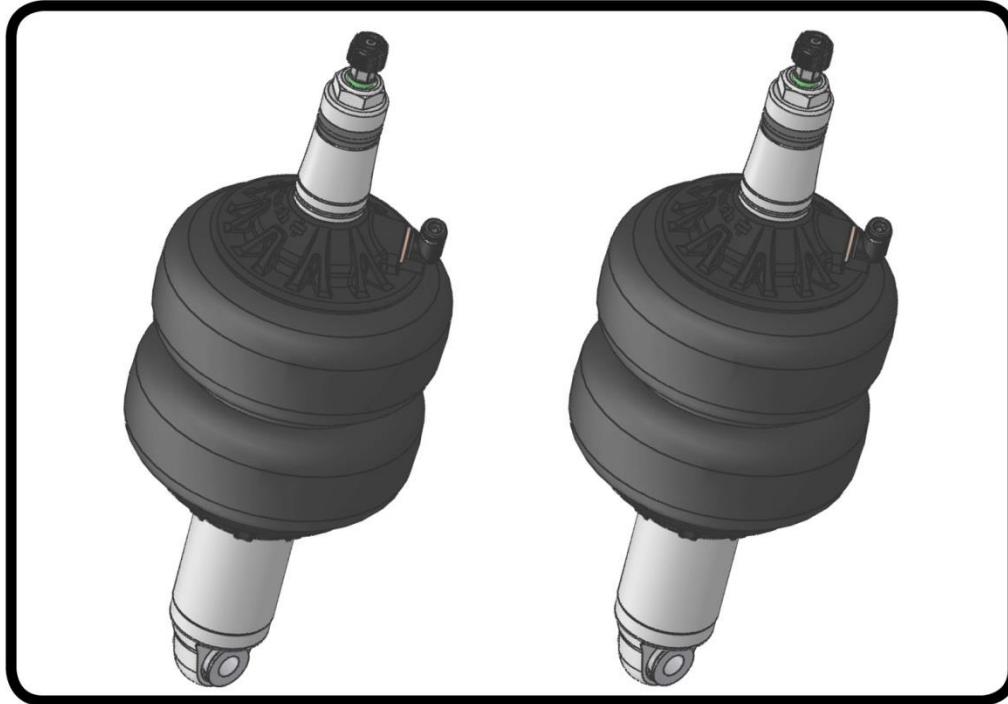

Recommended Tools



1000 Series Bellow, 2.75" Stud/Eye 3.6" Shock Installation Instructions

Table of contents

Page 2..... Included components

Page 3-4..... Shockwave Installation

Page 5-6..... Notes and Care of Your Shockwave & Shock Adjustment

ShockWave Dimensions:

Center of bearing to Center of bearing:

Compressed: 11.05"

Ride Height: 12.88"

Extended: 14.07"

THE DELRIN BALL REQUIRES A 3/4" HOLE FOR THE FLANGE TO GO THROUGH. THIS CAN BE DRILLED WITH A UNIBIT.

www.ridetech.com
812-482-2932





Major ComponentsIn the box

Item #	Part #	Description	QTY
1	24139999	3.6" Stroke HQ Series Shock	2
2	90009989	2.75" Stud Top (Installed on Shock) - Includes Adjuster Knob & Screw	2
3	24090199	1000 Series 6.5" Double Convoluted AirSpring	2
4	70010893	AirSpring Locking Ring (Installed on shock)	2
5	99055000	Locking Ring Set Screw (Installed on shock)	2
6	90002067	Spacers - INCLUDED WITH STRONGARMS	4
7	90002313	2.75" Aluminum Stud Top Base	2
8	90001904	Bottom Delrin Ball	2
9	90001903	Top Delrin Ball	2
10	90001902	Delrin Ball Aluminum Top Cap	2
11	99562003	9/16" -18 Thin Nylok Nut	2
12	90009972	Adjuster Knob - (90009989 assembly)	2
13	90009969	#4-40 X 1/4" SS, 18-8 Pan Head Torx Cap - (90009989 assembly)	2
	70012161	2.75" Stud Top Metering Rod (installed in stud top)	2
	90001994	5/8" ID Bearing (installed in shock and eyelet)	4
	90001995	Bearing Snap Ring (installed in shock and eyelet)	8

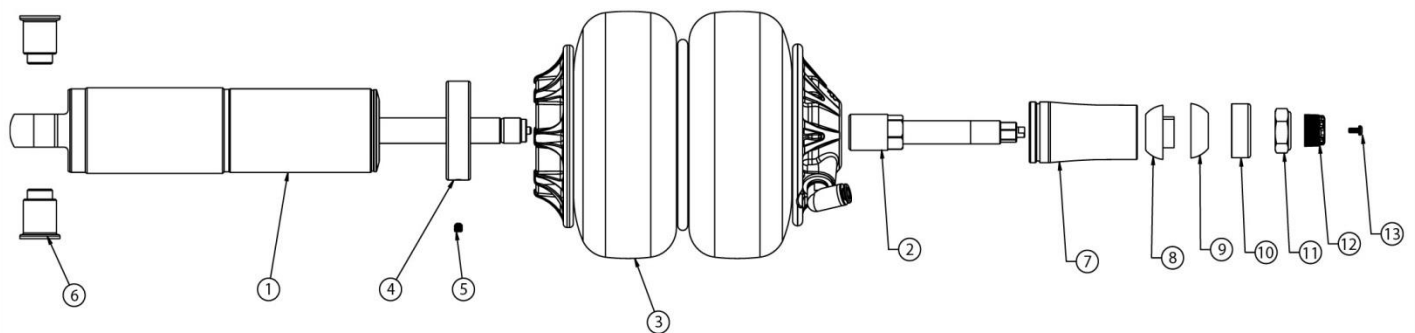

THE DELRIN BALL REQUIRES A 3/4" HOLE FOR THE FLANGE TO GO THROUGH. THIS CAN BE DRILLED WITH A UNIBIT.

WARNING: ATTEMPTING TO REMOVE THE AIR FITTING WILL DAMAGE IT AND VOID THE WARRANTY.



ShockWave Installation

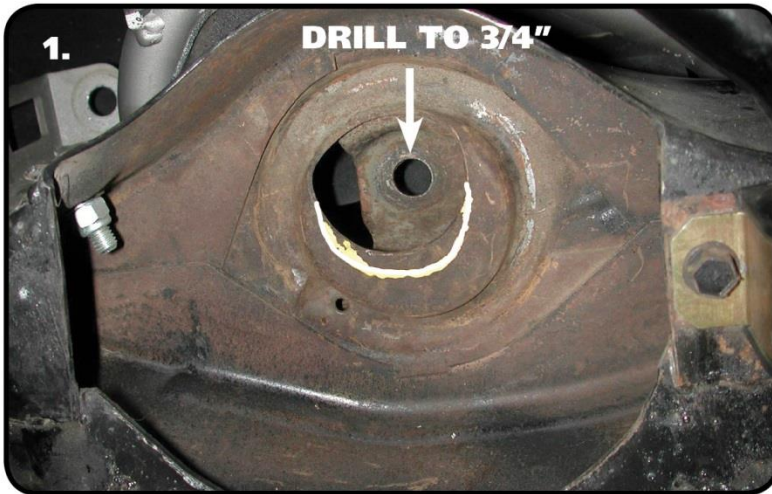

1. Drill the OEM shock hole out to 3/4". This can be done with a Unibit. The Shockwave stud top will come in contact with the coil spring retainer, so it must be opened up towards the engine. A die grinder works well here.



2. Some trimming must also be done on the outside of the frame pocket to allow clearance for the Shockwave.

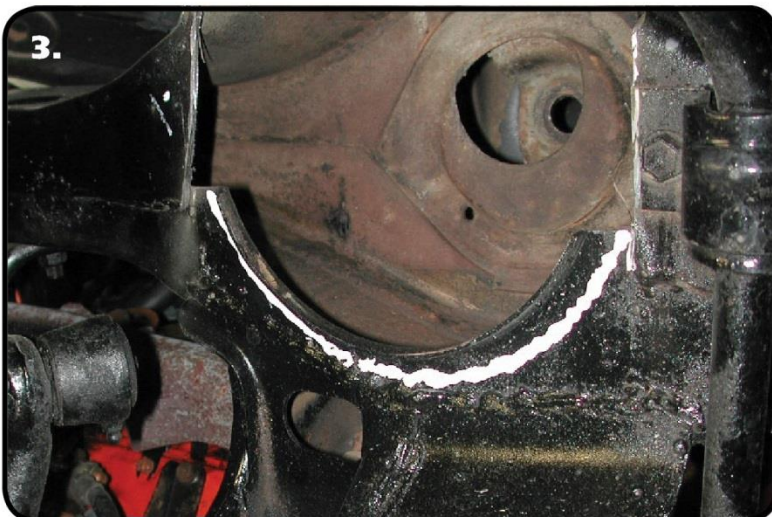

3. To allow clearance for the Shockwave, some trimming must be done on the inside of the coil spring pocket as shown by the white line in the picture. This is best done with either a cut off wheel or plasma cutter. Grind all cuts smooth when finished.

Note: It may be helpful to go ahead and install the lower StrongArms and Shockwaves to determine exactly what needs to be removed.



ShockWave Installation

4.

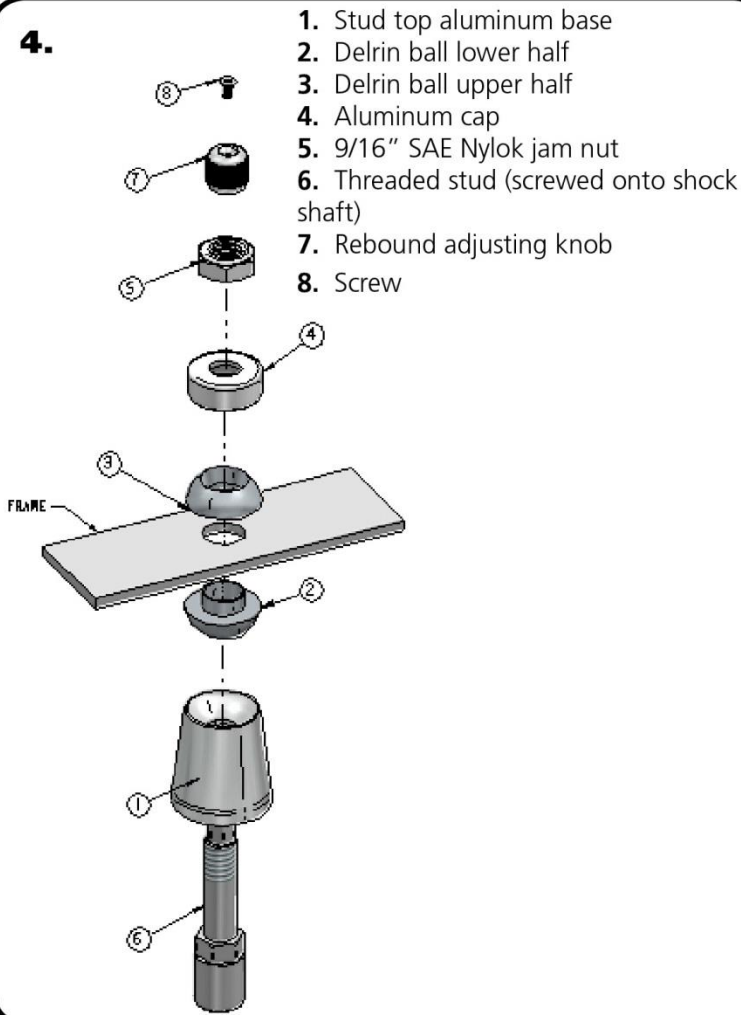

1. Stud top aluminum base
2. Delrin ball lower half
3. Delrin ball upper half
4. Aluminum cap
5. 9/16" SAE Nylok jam nut
6. Threaded stud (screwed onto shock shaft)
7. Rebound adjusting knob
8. Screw

Note: The airline must also be routed at this time. It can be ran through the subframe toward the rear of the vehicle.

4. The air fitting location can be rotated by twisting the bellow assembly separate of the shock. Place the Shockwave into the coil spring pocket with the stud sticking through the OEM shock hole. See assembly **Diagram 4**. OEM Shock hole **must** be drilled out to $\frac{3}{4}$ "

1. Stud top aluminum base
2. Delrin ball lower half
3. Delrin ball upper half
4. Aluminum cap
5. 9/16" SAE Nylok jam nut
6. Threaded stud (screwed onto shock shaft)
7. Rebound adjusting knob
8. Screw

5.

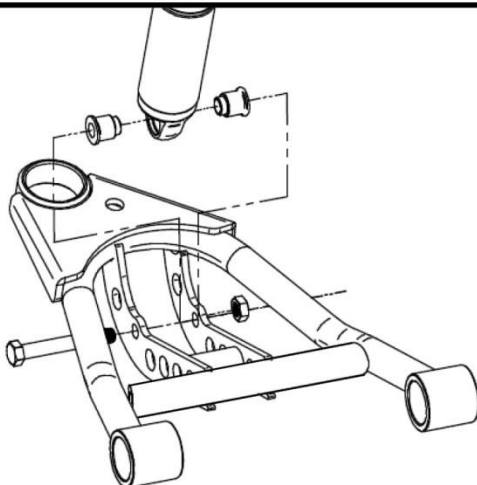

5. Raise the lower arm up to the Shockwave and bolt them together using the $\frac{1}{2}$ " x $3 \frac{1}{4}$ " bolt and Nylok supplied w/ the lower arms. An aluminum spacer will be on each side of the bearing. Torque to 75 ftbs.

6. Raise the lower control arm to full compression and double-check to make sure the Shockwave does not rub on anything at any-time. Allowing the Shockwave to rub on anything will cause failure and is not a warrantable situation.

7. The best ride quality will occur around 50-60% suspension travel; depending on vehicle weight this typically occurs around 85-100 psi.



Notes and Care of your Shockwaves

NOTES:

WARNING: ATTEMPTING TO REMOVE THE AIR FITTING WILL DAMAGE IT AND VOID THE WARRANTY.

TIGHTENING THE TOP 9/16"-18 NUT: SNUG THE NUT DOWN AGAINST THE TOP CAP. YOU NEED TO BE ABLE TO ARTICULATE THE SHOCK BY HAND.

You can clock the airfitting location on the ShockWave by turning the AirSpring assembly of the shock. Make sure the fitting doesn't contact the frame.

When cutting the airline, use a razor blade. The cut needs to be a clean cut and square for the airline to seal properly.

The Locking ring on the shock is **NOT** adjustable. These rings are set at the factory to optimize the AirSpring stroke with the shock stroke.

The care and feeding of your new ShockWaves

1. Although the ShockWave has an internal bumpstop, **DO NOT DRIVE THE VEHICLE DEFLATED RESTING ON THIS BUMPSTOP. DAMAGE WILL RESULT.** The internal bumpstop will be damaged, the shock bushings will be damaged, and the vehicle shock mounting points may be damaged to the point of failure. This is a non warrantable situation.
2. Do not drive the vehicle overinflated or "topped out". Over a period of time the shock valving will be damaged, possibly to the point of failure. This is a non warrantable situation! If you need to raise your vehicle higher than the ShockWave allows, you will need a longer unit.
3. The ShockWave is designed to give a great ride quality and to raise and lower the vehicle. **IT IS NOT MADE TO HOP OR JUMP!** If you want to hop or jump, hydraulics are a better choice. This abuse will result in bent piston rods, broken shock mounts, and destroyed bushings. This is a non warrantable situation.
4. Do not let the ShockWave bellows rub on anything. Failure will result. This is a non warrantable situation.
5. The ShockWave product has been field tested on numerous vehicles as well as subjected to many different stress tests to ensure that there are no leakage or durability problems. Failures have been nearly nonexistent unless abused as described above. If the Shockwave units are installed properly and are not abused, they will last many, many years. ShockWave units that are returned with broken mounts, bent piston rods, destroyed bumpstops or bushings, or abrasions on the bellows will not be warrantied.



350 S. St. Charles St. Jasper, In. 47546
Ph. 812.482.2932 Fax 812.634.6632

www.ridetech.com

Part # 11162899

67-69 GM "F" Body & 68-74 GM "X" Body Lower StrongArms

For Use w/ Shockwave or CoilOver

Components:

1	90000621	Driver side lower arm
1	90000622	Passenger side lower arm
2	90000898	Ball joint (includes boot, grease fitting, castle nut & cotter pin)
4	90000516	Inner bushing sleeve - .5" I.D. x .75" O.D. x 2.375" long
8	70010759	Delrin bushing half – 1.5" O.D.
4	90002062	Aluminum spacers – shock to lower arm

Hardware:

2	99501024	1/2"-13 x 3 1/4" Gr.5 bolt	Shockwave to lower arm
4	99501005	1/2"-13 x 3 1/2" Gr.5 bolt	Lower arm to frame
6	99502001	1/2"-13 Nylok Nut	Lower arm
2	99371010	3/8" x 5 1/2" USS bolt	Sway bar end link
4	99372002	3/8" USS Nylok Nut	Sway bar end link & Steering Stop
2	99371004	3/8" x 1 1/4" USS bolt	Steering stop

STRONG ARMS™

by Air Ride Technologies

Installation Instructions



1. After removing the factory lower control arm, clean the bushing mounting surfaces on the frame.
2. Fasten the lower arm to the frame with the $\frac{1}{2}$ " x $3 \frac{1}{2}$ " bolts and Nylok nuts supplied.

Note: On some cars the frame brackets may be pinched and will need to be spread back apart to allow bushing to slide in.

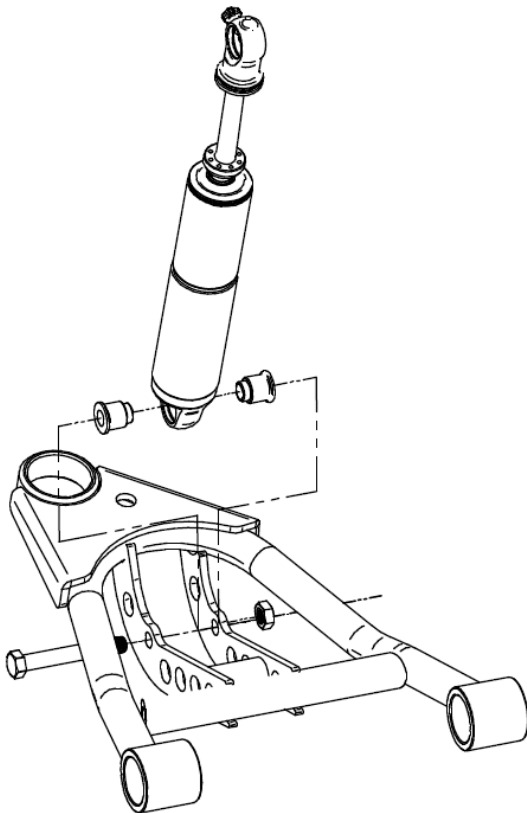

3. Swing the lower StrongArm up to the Shockwave and secure with the $\frac{1}{2}$ " x $3 \frac{1}{4}$ " bolt and Nylok nut, an aluminum spacer must be installed on each side of the bearing.
4. Slide the ball joint boot over the stud, then push the stud up through the spindle. Secure w/ the new castle nut and cotter pin supplied.
5. Grease the ball joints.
6. The Delrin Bushings are self-lubricating, no grease is required.



7. Screw a 3/8" x 1 1/4" bolt and nut into the hole in the side of the lower arm. This will act as an adjustable steering stop. After the wheel is install check wheel clearance all full lock and adjust as necessary.

8. If using factory style sway bar, shorten the sway bar end link spacer to 1 1/2" tall. New 3/8" x 5 1/2" bolts and Nylok nuts are supplied.

STRONG ARMS™

by Air Ride Technologies

Item #	Description	Qty.
1.	Passenger side arm	1
1.	Driver side arm	1
2.	Aluminum bearing spacer	4
3.	Ball joint	2
5.	Inner bushing sleeve	4
6.	1/2"-13 x 3 1/4" bolt	2
7.	1/2"-13 x 3 1/2" bolt	4
8.	1/2"-13 Nylok nut	6
9.	3/8"-16 x 1 1/4" bolt	2
10.	3/8"-16 Nylok nut	2
11.	Delrin Bushing Half	8

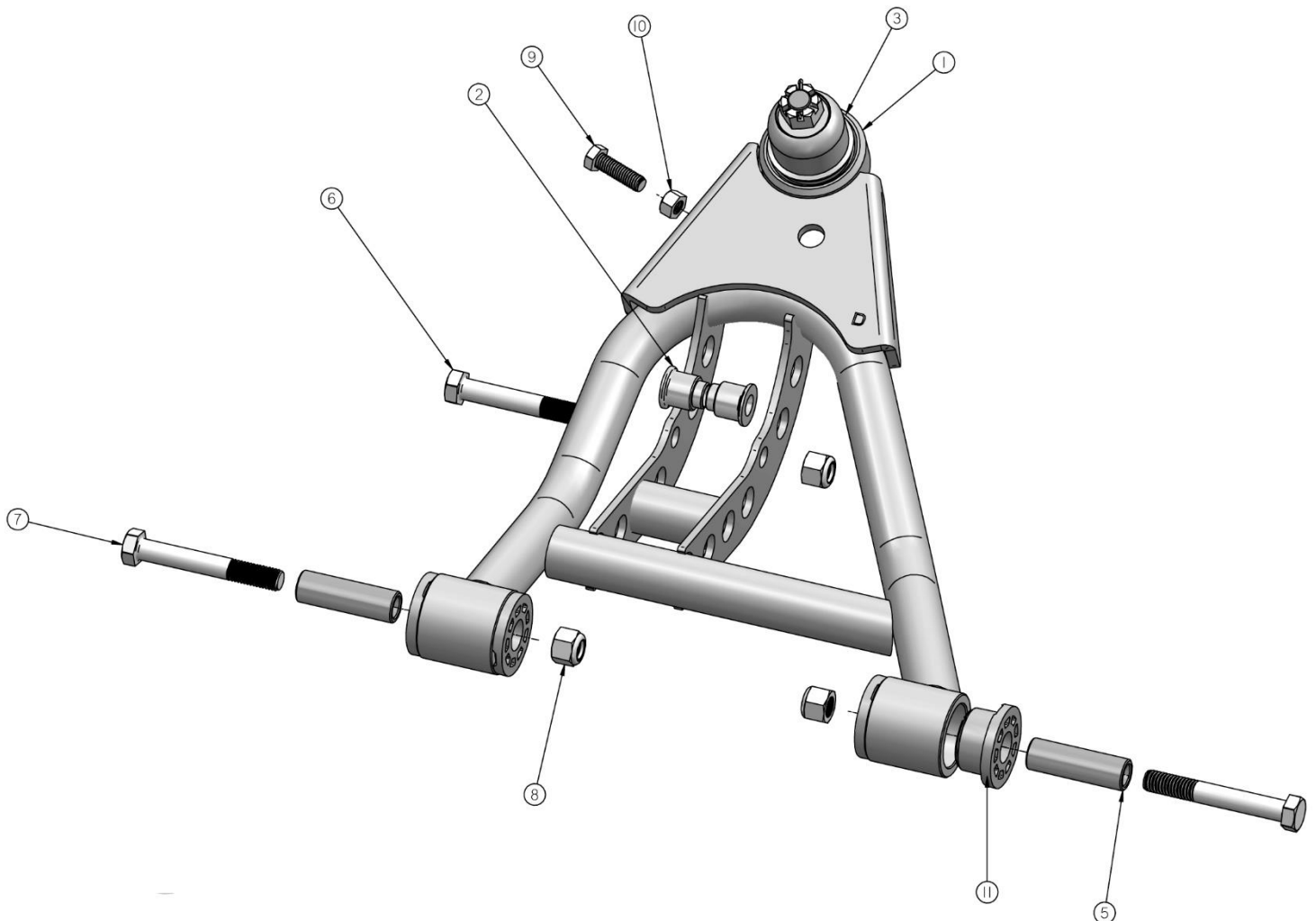



350 S. St. Charles St. Jasper, In. 47546
Ph. 812.482.2932 Fax 812.634.6632

www.ridetech.com

Part # 11163699
67-69 GM "F" Body & 68-74 GM "X" Body Upper StrongArms

Components:

1	90002390	Drivers side arm
1	90002391	Passenger side arm
2	90000908	Ball joint (includes boot, grease fitting, castle nut & cotter pin)
2	90000914	Caster Adjustable Cross shaft w/Hardware
2	70010826	Delrin Bushing – no ledge
2	70010827	Delrin Bushing – small ledge
4	70010759	Delrin Bushing – outer
4	90002737	Cross shaft T-washer
4	70010883	Zero Offset Caster Slugs
2	90001083	Medium bump stop w/ hardware

Installation Instructions



Driver Side Top View

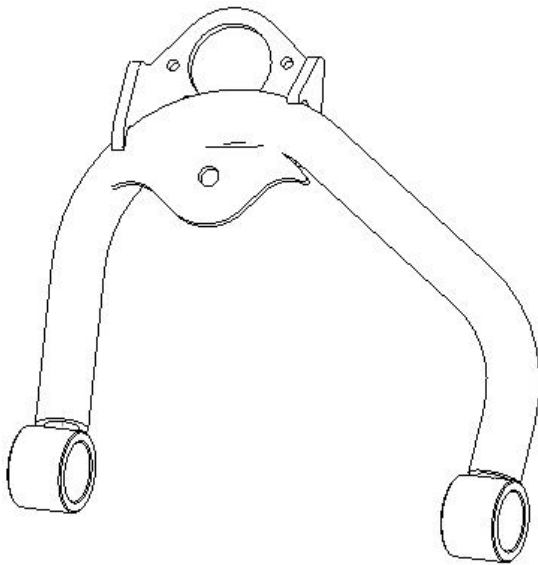

1. On some cars, to remove the upper control arm you must remove the bolts, which are pressed into the frame. We made a slide hammer adapter (a nut with a piece of angle iron welded to it) to aid in removing the bolts.

2. Fasten the upper arm to the frame using the factory hardware. Reinstall the current alignment shims, but **vehicle must be realigned**. This arm was designed with an extra 2 degrees of positive caster with the centered caster slugs. Additional caster slugs are available if more or less caster is desired. By changing the caster slugs you can achieve the caster setting you are wanting without having to run a lot of shims. Caster is explained on the next page.

3. Drop ball joint down through upper arm. Slide ball joint boot over stud, then place boot retainer over the boot. Clamp assembly tight w/ the hardware supplied.

4. Fasten the ball joint to the spindle w/ the new castle nut and cotter pin supplied.

5. Tighten the cross shaft nuts enough to create drag on the delrin bushings, the arm should still move.

6. Lubricate the ball joint w/ standard grease.

STRONG ARMS™

by Air Ride Technologies

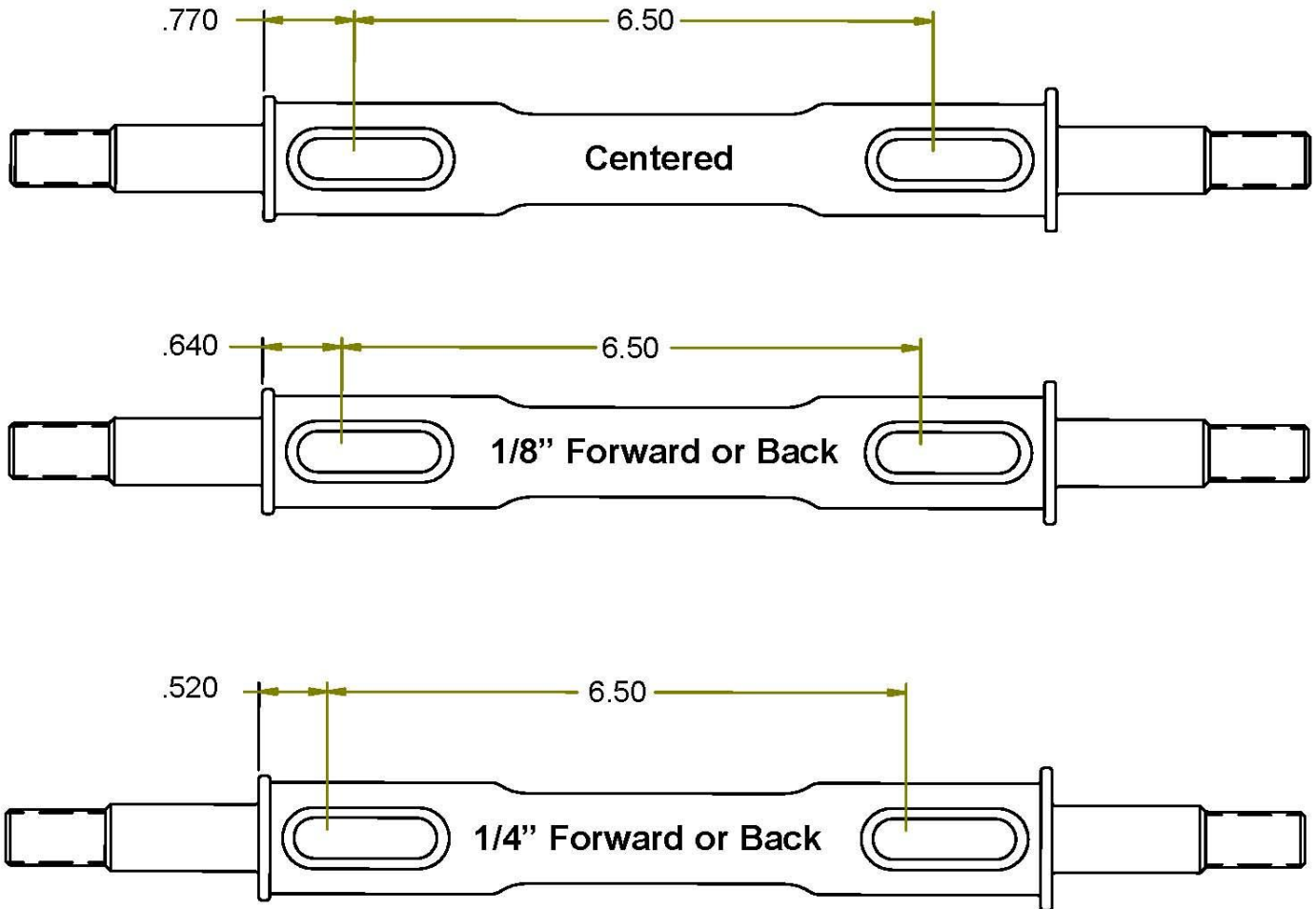

These Strong Arms come equipped with a changeable caster slug setup. This allows you to add or remove caster from the front suspension, if desired. The caster slugs that come in the kit are setup to put the control arm in the centered position, which is approximately 3 degrees of caster. The caster slugs allow you to add or remove caster without having to use a stack of shims. If more or less caster is desired, optional caster slugs can be purchased from your Ridetech dealer or Ridetech.

Caster Explained:

To understand caster you need to picture an imaginary line that runs through the upper ball joint and extends through the lower ball joint. From the side view the imaginary line will tilt forward or backward. The tilting of this imaginary line is defined as caster.

Caster is measured in degrees by using a caster camber gauge. If the imaginary line described above tilts towards the back of the car, at the top, then you will have positive caster. If the imaginary line tilts forward then you would have negative caster.

Positive caster provides the directional stability in your car. Too much positive caster will make the steering effort difficult. Power steering will allow you to run more positive caster. Negative caster requires less steering effort but can cause the car to wander down the highway.

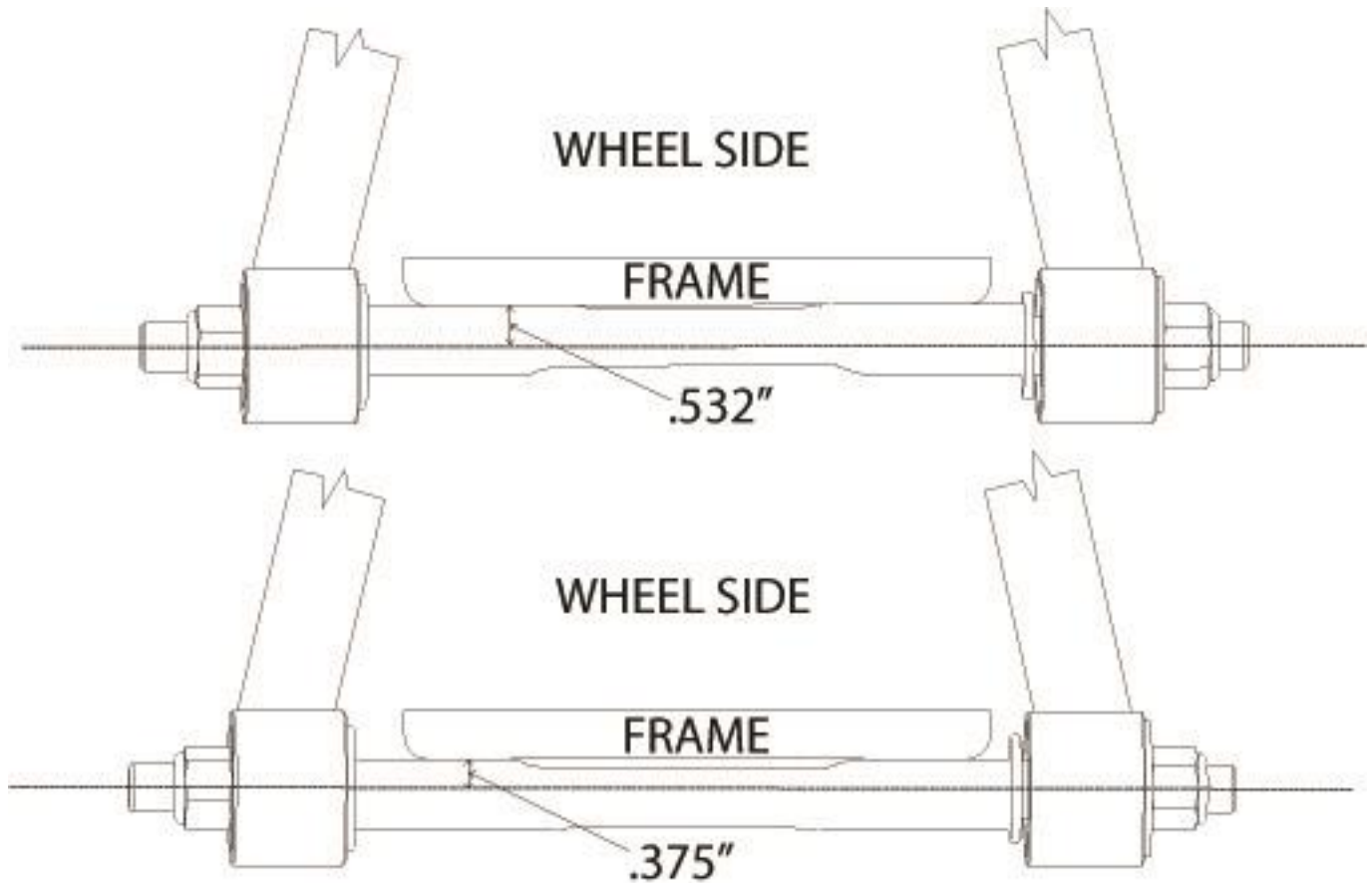

Offset Upper Cross Shaft

The cross shaft that is used in the upper control arm is offset. The offset combined with the caster slug option allows you to achieve the alignment setting you desire with minimal shims. To change the direction that the Icon faces, simply spin the cross shaft in the control arm.

If you are after an aggressive **Track or Autocross Alignment**, bolt the control arm to the frame bracket with the arm offset to the inside of the car (like the top illustration). The Ridetech Icon will be facing the engine.

If a **Street Alignment** is desired, bolt the control to the frame bracket with the arm offset to the outside of the car (like the bottom illustration). The Ridetech Icon will be facing the wheel.

STRONG ARMS™

by Air Ride Technologies

Item #	Description	Qty.
1.	Passenger side arm	1
1.	Driver side arm (Shown)	1
2.	Extension stop	2
3.	Ball joint	2
5.	3/8"-16 Nylok nut & washer	2
6.	1/4"-28 x 7/8" hex bolt	8
7.	1/4"-28 nut	8
8.	Inner Delrin bushing w/ledge	2
9.	Inner Delrin bushing no ledge	2
10.	Outer Delrin bushing	4
11.	T-Washer washer	4
12.	5/8"-18 lock nut	4
13.	Caster Adjustable Cross shaft	2
14.	Caster Slug	4

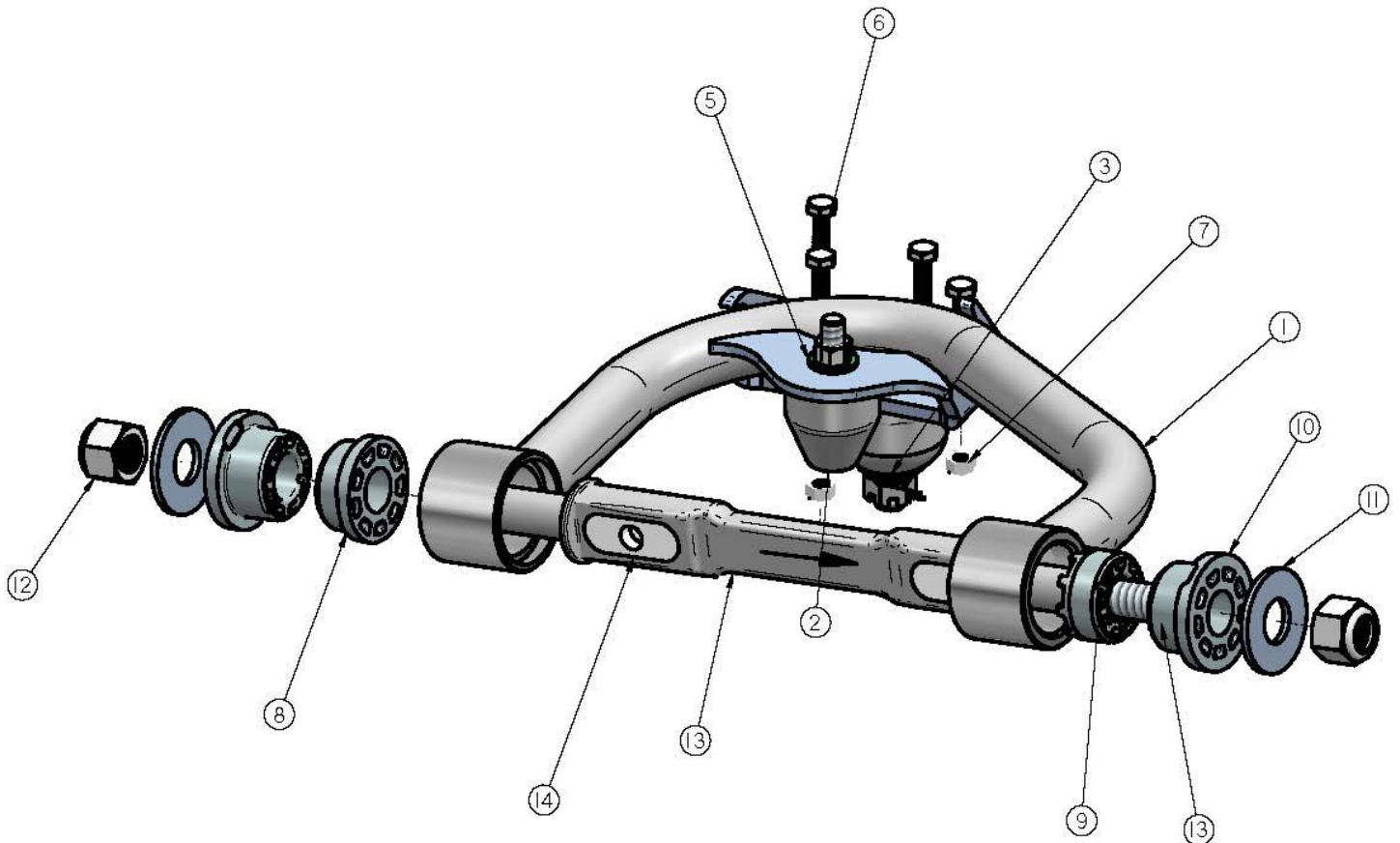



350 S. St. Charles St. Jasper, In. 47546
Ph. 812.482.2932 Fax 812.634.6632

www.ridetech.com

11009300 GM "A" & "F" Body Tall Spindles

2 Tall Spindles

Hardware:

Lower steering arm bolts

(4) 1/2NFX 2 1/2" flathead socket head bolts with Nyloc nuts

Lower caliper bracket bolts

(2) 1/2NFX 2" flathead socket head bolts with Nyloc nuts (Wilwood and Baer Brake kits)

(2) 1/2NFX 2" Grade 8 hex head bolts (use with stock stamped 1/2" thick caliper brackets)

INSTRUCTIONS FOR Ridetech Tall SPINDLES

These spindles will fit '67-69 Camaro, '64-'72 Chevelle, and '68-'74 Nova. They will provide a 2" drop, and are taller than stock to improve the car's cornering ability. The raised upper ball joint will cause the tires to lean into the corner, like a motorcycle, rather than outboard as the shorter stock spindles do. This camber action change also raises the roll center for less body roll, and transfer the car's center of gravity inboard in the turn as well. You will see an appreciable improvement in handling. Standard size anti sway bars will work well with those improvements, without the need for monster sway bars that can cause a harsh ride.

The spindles are modeled after stock disc brake spindles and will accept any disc brake set up designed for those. If your car came with drum brakes, be sure to swap to the appropriate disc brake master cylinder and valving. We have test fitted ECI, Wilwood, Baer, Aerospace, and stock GM kits. The only modification we discovered to be necessary was a small trim on the bottom of the stamped ¼" steel caliper bracket that holds the caliper. It is an area that is not stressed and will not cause any loss of strength. There are variations among the various reproduction the shaft to be flipped in it's bushings for brackets, so the trim will be seen only on some of those.

Stock stamped control arms will accept these spindles, as will any aftermarket arms we have seen. Our own tubular control arms have the upper ball joint plates rotated slightly for better ball joint angles on lowered cars. We also set the ball joint ¾" to the rear of the car to allow more aggressive positive caster settings, as well as to compensate for the normal forward rake seen on hot rods. The upper control arms shaft has a 3/16" offset, allowing the shaft to be rotated in it's bushings for a 3/8" net change in the upper arm's effective length. That design was pioneered by the MOOG company, as many stock autos suffer from a sagged cross member, making it difficult to obtain good alignment numbers. We suggest the alignment be done with 1/8" toe in, ½ degree positive camber, and 3 degrees positive caster with power steering, 2 degrees manual.

It is important to be sure you have the proper steering arms. Many cars were updated to disc brakes in the past by using disc brake and spindle assemblies from a donor car. However, the Chevelle steering arms are front steer, and the tie rod is roughly the same height as the lower ball joint. The Camaro and Nova arms are rear steer, with the outer tie rod end much lower than the ball joint. If the incorrect arms are used, the incorrect height tie rod end will cause major bump steer problems. Our testing of prototype versions of these spindles revealed that a small additional lowering of the mounting holes for the steering arms was necessary to remove the small amount of factory bumpsteer, and to account for the changes made by the taller spindle. We included that enhancement in the production version of your new dropped spindles.



Disassembly of the ball joints from the spindles can be eased by making the simple tool shown in the photo below. A pair of 1 ½" long bolts are threaded into a matching hex coupler. The ball joint cotter pins are removed, and the hex nuts loosened a couple turns. Place the tool between the ball joint studs, and turn a bolt to expand the tool, gently popping the ball joint studs loose. If your ball joint boots are torn, as often happens when a pickle fork is used to separate the ball joints, NAPA has replacements. The best way to remove the outer tie rod pivot is to loosen the hex nut, and then rap the steering arm boss with a hammer. Tie rod ends pullers are also available if you want to be more gentle on the parts. Do NOT hammer on the tie rod stud itself! Be sure to leave the shock absorber in place to control the spring and prevent it jumping out.

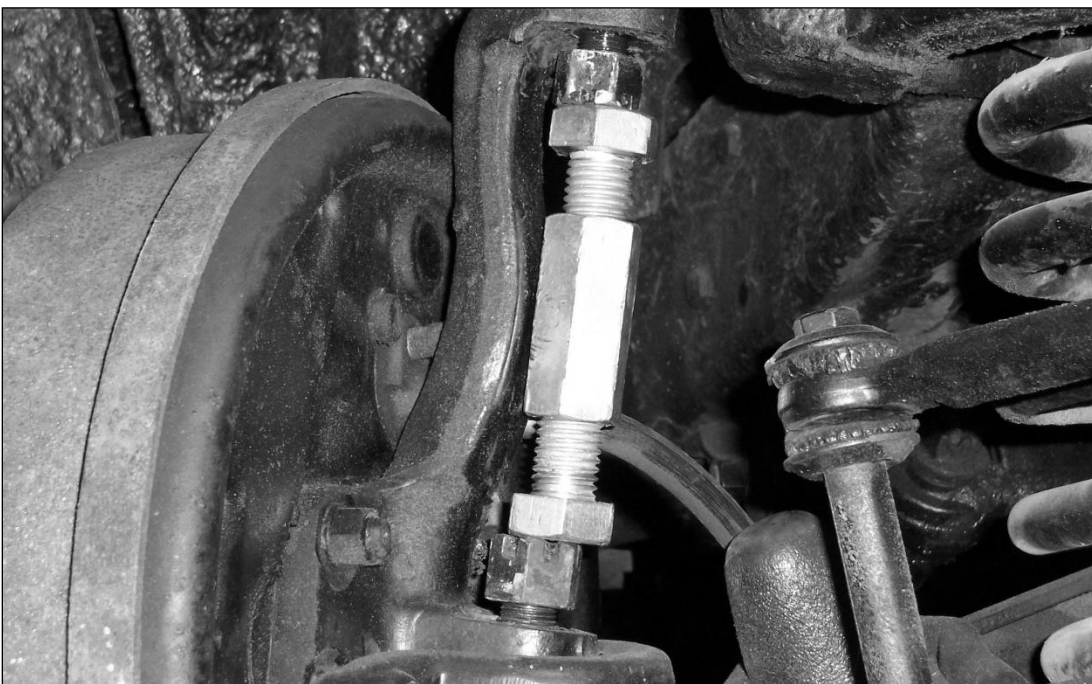

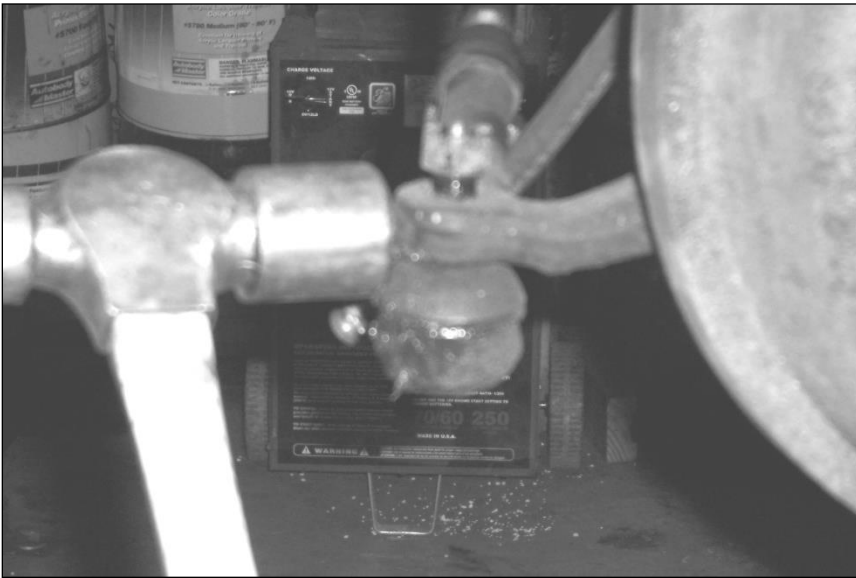

If you remove the calipers but leave the hoses attached, supporting them to avoid stressing the hoses, you won't even need to rebleed the brakes!

Reattach the new spindle, being sure to get the castle nuts tight, and install new cotter pins. Attach the steering arms into the lower holes in the spindles using the 4 supplied 1/2NFx2 1/2" long flathead bolts and Nylok nuts supplied. The 1/2NFx 2" long flat head bolts and nylok nuts we supply are for use with Wilwood and Baer brake kit lower bracket bolts. The 1/2NFx2" hex head bolts are used with stock caliper brackets. Reassemble your disc brakes as well. Now would be a good time to clean and grease the bearings.

BEFORE you try moving the car, pump the brakes to reset the pads to the rotors. Rebleed if necessary. Have the alignment shop set the car with 1/2 degree negative camber, 3-5 degrees positive caster, and 1/16"-1/8" toe in. We're sure you'll be amazed at the difference in handling!



Note: If using a factory style stamped caliper bracket, the bracket may need to be trimmed. The dust shield may also need to be modified.



350 S. St. Charles St. Jasper, In. 47546
Ph. 812.482.2932 Fax 812.634.6632

www.ridetech.com

Part # 11169100
**67-69 GM "F" Body & 68-74 GM "X" Body Front MuscleBar
w/ PosiLinks**

Components:

1	90000116	Sway bar	
1	90000121	Driver side arm	
1	90000122	Passenger side arm	
2	90000137	Frame bracket	
2	90001099	Polyurethane frame bushing	
2	90000924	10mm straight PosiLink	
2	90000926	10mm 90 degree PosiLink	
4	90000717	T-bushings	
2	99250001	Grease Zerk fittings – ¼"-20	
2	90001092	Tube of lithium grease	
2	99115001	10 x 1.5 x 36mm stud	In PosiLinks (use Loc-tite)

Hardware Kit: 99010044

4	99112002	10mm Nylok nut	PosiLinks
2	99373003	3/8" SAE flat washer	PosiLinks
4	99311009	5/16" x 1" USS SHCS	Frame bracket
4	99312003	5/16" USS Nylok nut	Frame bracket
8	99313002	5/16" SAE flat washer	Frame bracket
6	99371021	3/8"-16 x 1" FHSCS	Arm to sway bar (Use Loc-tite)
2	99502003	½" SAE Nylok jam nut	Steering arm

MUSCLEbar[™]

by Air Ride Technologies

POSI • *Link*[™]

11169100 Installation Instructions

1. This sway bar is designed for use with our lower StrongArms. Installation on other arms may require modification.
2. Remove the end links from the factory sway bar. Then remove the bolts attaching the sway bar to the frame.
3. On some cars, the compression stop bracket that is welded to the frame will need to be removed to allow clearance for the sway bar arm.



3. On some cars, the compression stop bracket that is welded to the frame will need to be removed to allow clearance for the sway bar arm.



4. Apply lithium grease to the poly bushing then slide it over the sway bar.



5. Secure the sway bar to the frame with two 5/16" x 1" Socket Head Cap Screws, flat washers and Nylok nuts.

Note: Due to the larger diameter bar, the front hole must be drilled with a 5/16 bit, in front of the factory hole. Use the bracket as a template.



6. On some cars clearance of the cross member may be needed for sway bar clearance.



7. Attach the arm to the bar using three 3/8" x 1" Flat Head Cap Screws. **Blue or Green Loc-tite must be applied to the threads of these bolts.**

Note: With the Arms installed, the lower portion of the MuscleBar should be towards the ground. If it is pointing toward the front of the car, remove the bar a flip it end for end and reinstall the bar and arms.

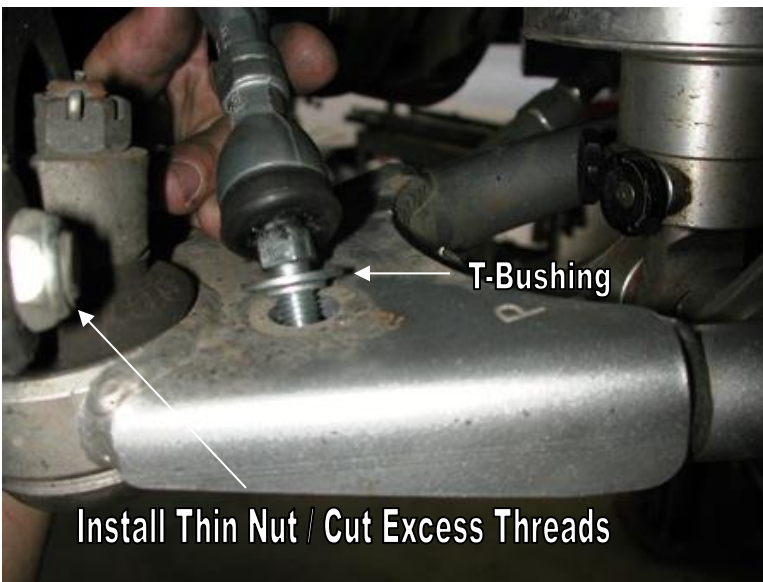

8. The straight end of the PosiLink will attach to the lower control arm. **A "T"-Bushing must be installed on each side of the control arm.** Secure the assembly with a 10mm Nylok nut.

Note: To avoid the front steering arm bolt hitting the PosiLink, a thin Nylok jam nut is installed and the excess threads must be cut off.



9. Attach the other end of the PosiLink to the sway bar arm with a 3/8" flat washer and a 10mm Nylok nut.

10. Check sway bar and PosiLink clearance through full suspension travel, turning the wheel lock to lock. Make sure that the PosiLinks do not bind.



350 S. St. Charles St. Jasper, In. 47546
Ph. 812.482.2932 Fax 812.634.6632

www.ridetech.com

Part # 11267199
68-72 Nova Rear AirBar

Components:

1	90002077	Lower axle bracket – Driver
1	90002078	Lower axle bracket - Passenger
2	90001624	Lower billet Shockwave mount
2	90001617	Lower Shockwave stud
4	90002067	Aluminum spacer for stud
2	90000704	Tall Axle tabs (Outside)
2	90000705	Short Axle tabs (Inside)
1	90000703	Upper cradle assembly
2	90002857	Upper bars – TW 7.375" (C-C length 9.250")
2	90002860	Lower bars – WW 24.75"
2	70013364	R-Joint Housing end
2	99752004	3/4"-16 jam nut – for rod end
14	70013334	R-Joint Spacers
2	70013537	Front Lower outer R-Joint Spacer
2	70010694	Jig brackets for upper bar installation



R-Joint Components (installed in bar ends)

70013279	Retaining Ring
70012380	Wavo Wave Spring
70013275	R-Joint Center Ball
70013276	R-Joint Composite Center Ball Cage

MODIFICATIONS MAY BE NECESSARY TO FIT 1973 & 1974 NOVA.

Hardware Kit: (Part # 99010030)

Front of lower bar

2	99621007	5/8"-18 x 5" bolt
2	99622006	5/8"-18 Nylok jam nut
2	99623010	5/8" sae Flat washer

Billet mount to axle bracket

2	99501019	1/2"-13 x 1 1/4" Gr. 5 bolt
2	99501046	1/2"-13 x 1 3/4" Gr. 5 bolt
4	99502001	1/2"-13 Nylok nut

Bar ends

6	99621020	5/8"-11 x 2 3/4" Gr.5 bolt
6	99622008	5/8"-11 Nylok jam nut

Upper Shockwave mount

2	99501026	1/2"-13 x 2 1/4 Gr.5 bolt
2	99502007	1/2"-13 Nylok jam nut

Upper cradle assembly

16	99373007	3/8"-16 x 1" Thread forming bolt
16	99373003	3/8" SAE flat washer

Lower axle mount - U bolts

8	99432002	7/16"-20 Nylok nut
---	----------	--------------------

Upper bar installation jig

2	99371001	3/8"-16 x 3/4" Gr. 5 bolt
2	99372004	3/8"-16 nut

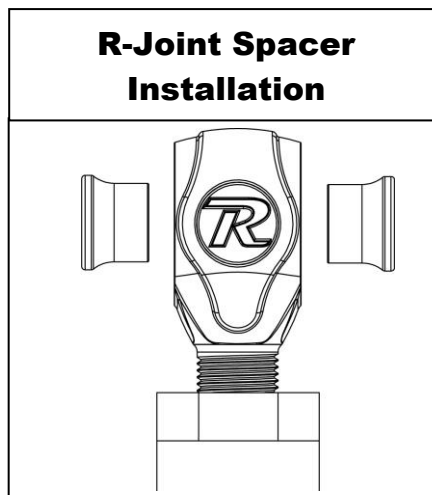

New R-Joints will be quite stiff (75-90 in/lbs breakaway torque) until they "break in" after a few miles of use. After the break in period they will move much more freely. Because the composite bearing race contains self-lubricating ingredients, no additional lubrication is needed or desired. Any additional lubrication will only serve to attract more dirt and debris to the R-Joint and actually shorten its life.

AirBAR[®]

by Air Ride Technologies

1. Raise the vehicle to a safe and comfortable working height. Use jack stands to support the vehicle with the suspension hanging freely.
2. Support the axle and remove the bump stops, leaf springs, shocks and tail pipes. Refer to the factory service manual for proper disassemble procedures. Keep the factory upper shock bolts, bump stop bolts, U-bolts, and front leaf spring mount and bolts.



3. One more thing needs to be removed before starting the assembly; it's the pinion snubber and mount. For a clean cut use a cut off wheel and smooth any burrs.

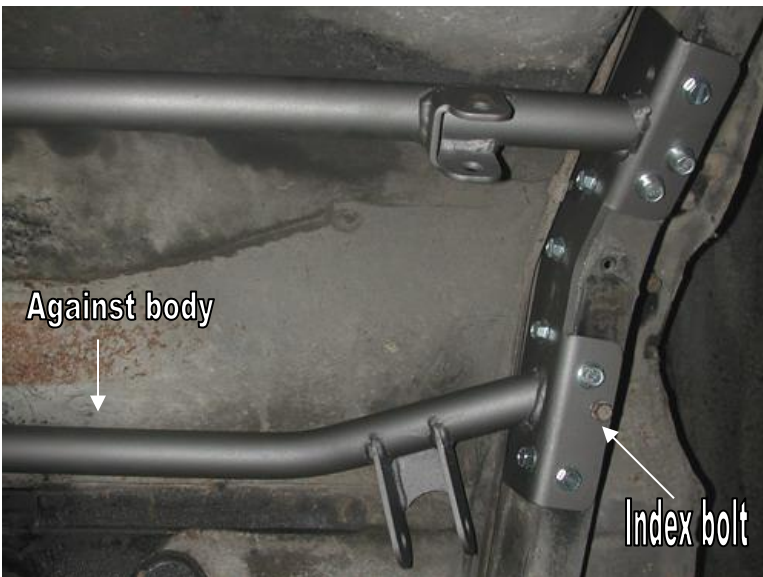

4. Lower the axle enough to slide the upper cradle into place. On most cars the location of the cradle will index off of the factory bump stop bolt hole. If your car has the bump stop beside the frame, slide the cradle forward until the front tube touches the body.

Note: The gas line may need to be moved.

5. A series of self-tapping 3/8" bolts are used to hold the cradle in place. First drill the holes with a 5/16" bit and then thread the bolts into the frame.



6. The heim end bar setup is designed to be offset to the inside of the car. The bolt hole in the mounting bracket has to be drilled out to 5/8" and the new longer bolt is used. The wider spacer is used on the outside with a narrow spacer on the inside. The bar is offset to provide better wheel and tire clearance.

The bolt needs to go in the bracket like seen in the picture

7. Bolt the bar and mount back onto the car using the factory hardware.

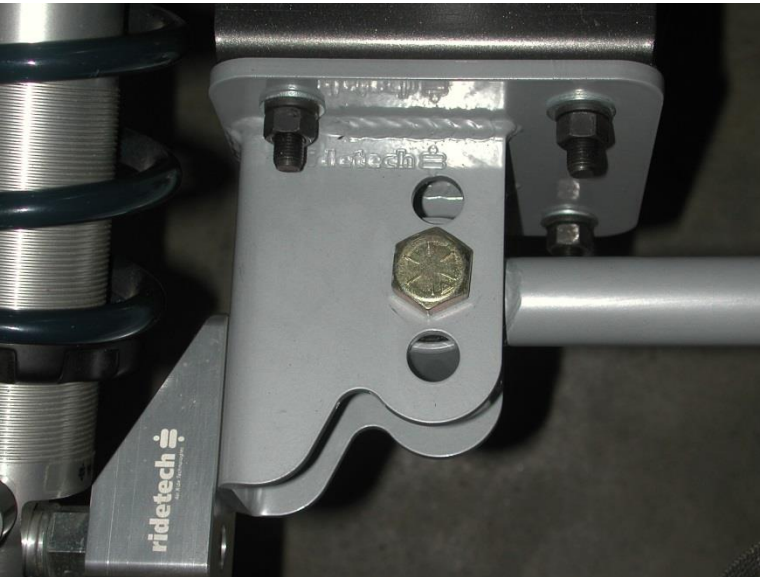

8. The lower axle bracket will be fastened to the leaf spring pad using the factory U-bolts. It is offset to the inside of the car. New 7/16" nylocs are supplied.

9. Bolt the lower Shockwave mount to the lower holes of the axle bracket if you have a monoleaf car. If you have a multileaf car the bottom of the billet mount will be flush with the axle bracket.

10. Insert R-Joint Spacers into each side of the center pivot of the R-Joint. Swing the lower bar up to the axle bracket and insert 5/8" x 2 3/4" bolt. The standard hole is the center hole like in the picture. Thread 5/8" Nylok onto the bolt but **do not tighten** yet.



11. Check the length of the upper bar; it should be 9 1/4" C-C. Bolt the axle tabs to the setting jig (**The setting jig is explained on the next page**) . (Longer ears to the front) Then place the other end of the jig into the cradle. Both ends use a 5/8" x 2 3/4" and should not be fully tightened yet. For now just the let axle tabs sit on the axle.

12. Before welding these tabs to the axle you will need to center the axle and set pinion angle. We used a plum on the outside of the quarter panel to center the axle left to right. Setting the pinion angle is explained on the pinion angle page.

This must be done at ride height.

Upper Bar Installation Jig

- This jig has been supplied to aid in the installation of the upper 4 link bar. It can be temporarily used to properly align, locate and weld the tabs onto the axle. It will also ensure that the mounting bolts are parallel to the ground.
- Follow the diagram below to set the jig to the same length as the upper bar, use the 3/8" x 3/4" bolt and nuts to set the length.
- Position the axle at ride height. Center the axle left to right between the quarter panels. Set pinion angle.
- Bolt one end of the jig to the cradle using a 5/8" x 2 3/4" bolt.
- Using another 5/8" x 2 3/4" bolt, fasten the axle tabs to the other end. The tabs must be bolted to the **outside** of the jig. **Short tab goes to the inside with the long ear forward, the Tall Tab goes to the outside of the car with the long tab forward.**
- Swing the bar down letting the tabs rest onto the axle. Trim the brackets as necessary to minimize the gap to be welded.
- Check pinion angle, ride height and axle center. Tack-weld the tabs in place.
- Remove jig and install upper bar.
- Repeat this process for the other side.
- Recheck pinion angle, ride height and axle center. (Sound familiar?)
- After the tabs have been tack welded on both sides, remove the upper bars to avoid melting the rubber bushings. Let the axle drop down for better access to the tabs. Lay 1" welds on the inside and outside of the tabs. Skip around from one side to the other to avoid overheating the tube.

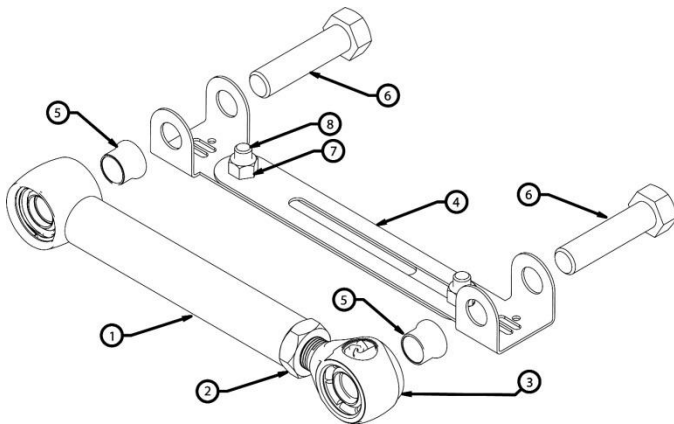

Item #	Description
1.	Upper bar
2.	3/4"-16 jam nut
3.	R-Joint End
4.	Alignment jig
5.	R-Joint spacer
6.	5/8"-11 x 2 3/4" bolt
7.	3/8"-16 nut
8.	3/8"-16 x 3/4" bolt



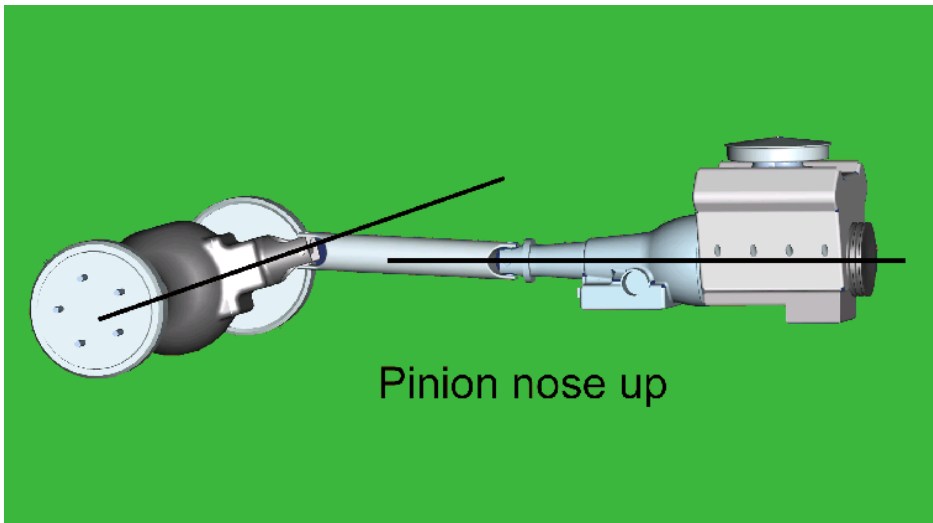
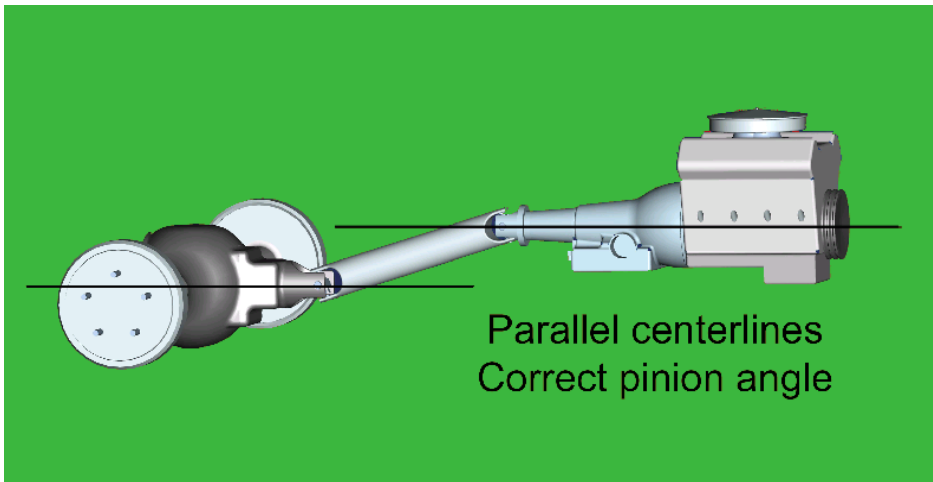
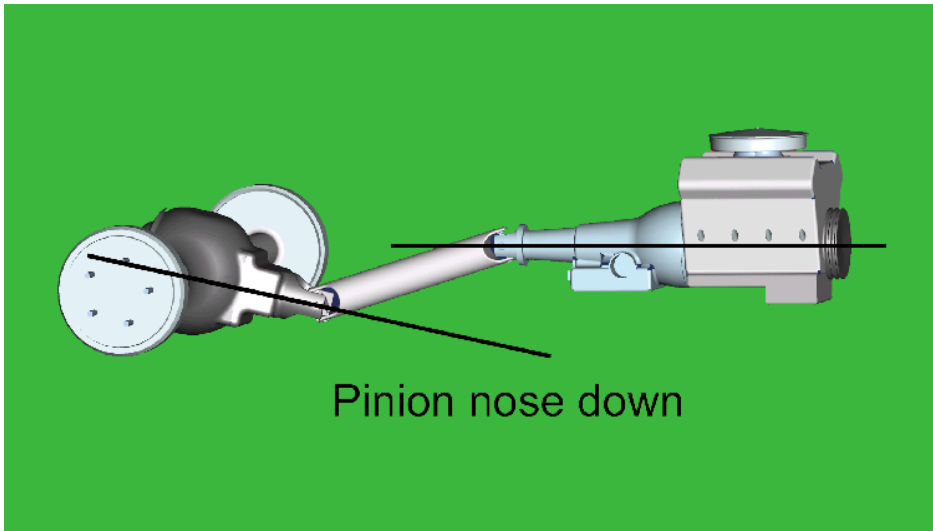

13. How do you set the pinion angle? On a single-piece shaft you want to set it up where a line drawn through the center of the engine crankshaft or output shaft of the transmission and a line drawn through the center of the pinion are parallel to each other but not the same line.

Your transmission angle should be around 3 degrees down in the rear. If it is more or less than 3 degrees, you might want to consider changing it. Too little angle on the transmission reduces the amount of oil getting to the rear bushing. Too much transmission angle will increase the working angles of the u-joints which will increase the wear. With the transmission at 3 degrees down in the rear, you will want to set the pinion 3 degrees up in the front.

A simple way to do this is to place a digital angle finder or dial level on the front face of the lower engine pulley or harmonic balancer. This will give you a reading that is 90 degrees to the crank or output shaft unless you have real problems with your balancer. At the other end, you can place the same level or angle finder against the front face of the pinion yoke that is also at 90 degrees to the centerline. If you rotate the yoke up or down so both angles match, you have perfect alignment.

Road testing will tell you if you have it right. If you accelerate and you get or increase a vibration, then the pinion yoke is too HIGH. Rotate it downward in small increments of a degree or two until the problem goes away. If you get or increase a vibration when decelerating, then the pinion yoke is too LOW. Rotate it upward to correct it.



14. One helpful trick to help maintain ride height and pinion angle while adjusting is to tack weld a spacer between the axle and the outside of the frame as shown in the picture. This spacer should be 8 3/8" tall giving the Shockwave an eye-to-eye measurement of 14 1/2" to 15".

15. After double-checking pinion angle, ride height, and axle center the tabs can be tack welded.

16. Tack-weld the tabs to the axle then recheck alignment. To avoid warping the axle, weld 1" at a time and skip around.

17. Insert R-Joint spacers into the r-Joint in the upper bars and install the bars using 5/8" x 2 3/4" Bolts and 5/8" Nylok Nuts.



18. Apply thread sealant to the air fitting and screw it into the Shockwave.

19. Install the Shockwaves using the 1/2" x 2 1/4" bolt and nyloc on top and the 7/16" nyloc on the lower stud mount. There should be a washer on either side of the Shockwave on the stud and none on the upper mount.

20. You can now go back and snug all of the bar end nylocs. This must be done at ride height.

21. You can now remove the spacer from between the axle and frame.

22. The installation is complete but you want to check clearance of the brake lines, parking brake cables, vent tubes and exhaust. For the exhaust you can either install a turndown or reroute the exhaust under the axle.

23. Ride height is 14.5", around 70psi.

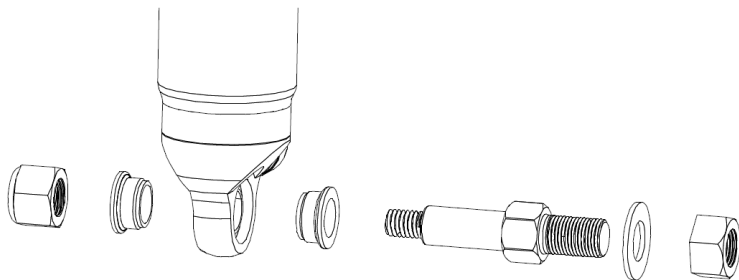



350 S. St. Charles St. Jasper, In. 47546
Ph. 812.482.2932 Fax 812.634.6632

www.ridetech.com

Should I weld my AirBar 4 link assembly in?

Since we get this question quite often, it deserves a proper explanation.

The AirBar has been designed for bolt-in installation. We have paid special attention to interfacing with key structural areas of each vehicle, fastening bracketry in at least two planes to properly distribute load paths, and to using appropriate fasteners that roll, rather than cut, threads into the vehicle structure.

Having said that, you could potentially encounter a vehicle that has rust or collision damage in these areas. Or maybe you intend to consistently place the vehicle in severe racing applications with sticky racing slicks and high speed corners. In these cases it is perfectly acceptable to weld the AirBar components into your vehicle. Even in these severe cases we recommend that you install the entire AirBar assembly first [including the fasteners], and then use short 1" long tack welds to secure your installation. Remember that the vehicle structure metal is typically much thinner [.060"-.120"] than the .188" thick AirBar brackets. If you burn through the vehicle sheet metal structure you may end up with an installation that is weaker than before you tried to weld it.

The other reason to weld in your AirBar assembly is...you simply want to. You're a welding kind of guy...that's the way you've always done it...you have the skills and equipment to do it. In that case...weld away with our blessing!



Part # 21150701 - 5.2" Stroke HQ Series Shockwave

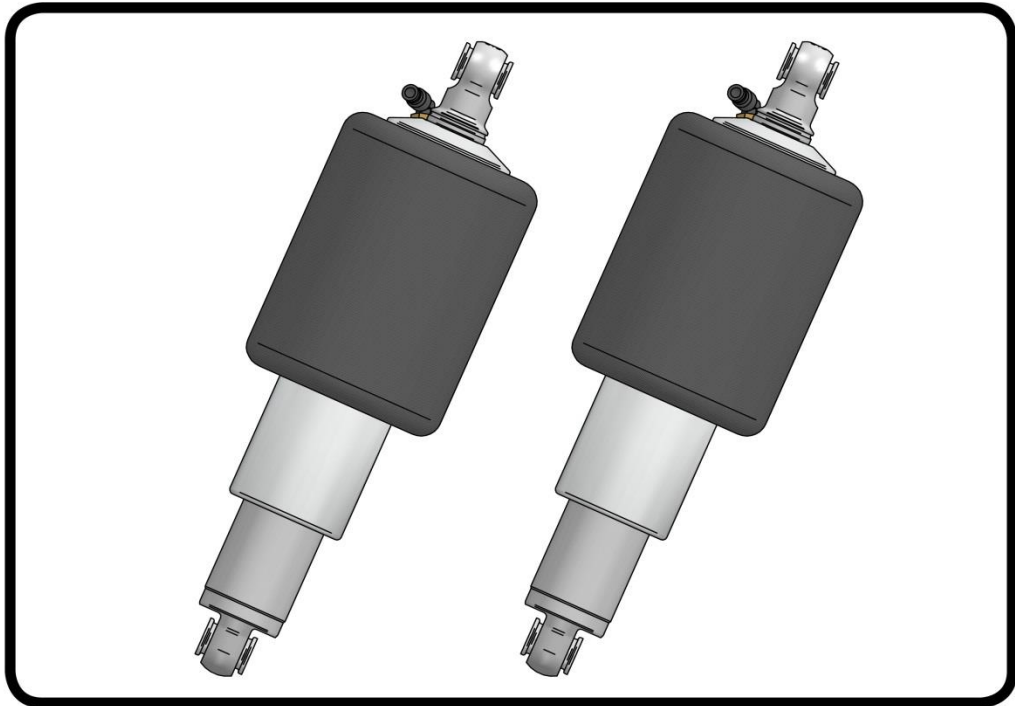

Recommended Tools



7000 Series Bellow, Eye/Eye 5.2" Shock Installation Instructions

Table of contents

Page 2..... Included components

Page 3..... Notes and Care of Your Shockwave

Page 4..... Shock Adjustment

ShockWave Dimensions:

Center of bearing to Center of bearing:	
Compressed:	11.85"
Ride Height:	14.60"
Extended:	16.42"



Major ComponentsIn the box

Item #	Part #	Description	QTY
1	24159999	5.2" Stroke HQ Series Shock	2
2	90002024	Shock Eyelet	2
3	24090799	7000 Series, 4" Diameter AirSpring	2
4	70008193	AirSpring Locking Ring (Installed on Shock)	2
5	90002044	Spacer kit - 1/2" ID and 5/8" ID	4
	90001994	5/8" ID Bearing (installed in shock and eyelet)	4
	90001995	Bearing Snap Ring (installed in shock and eyelet)	8

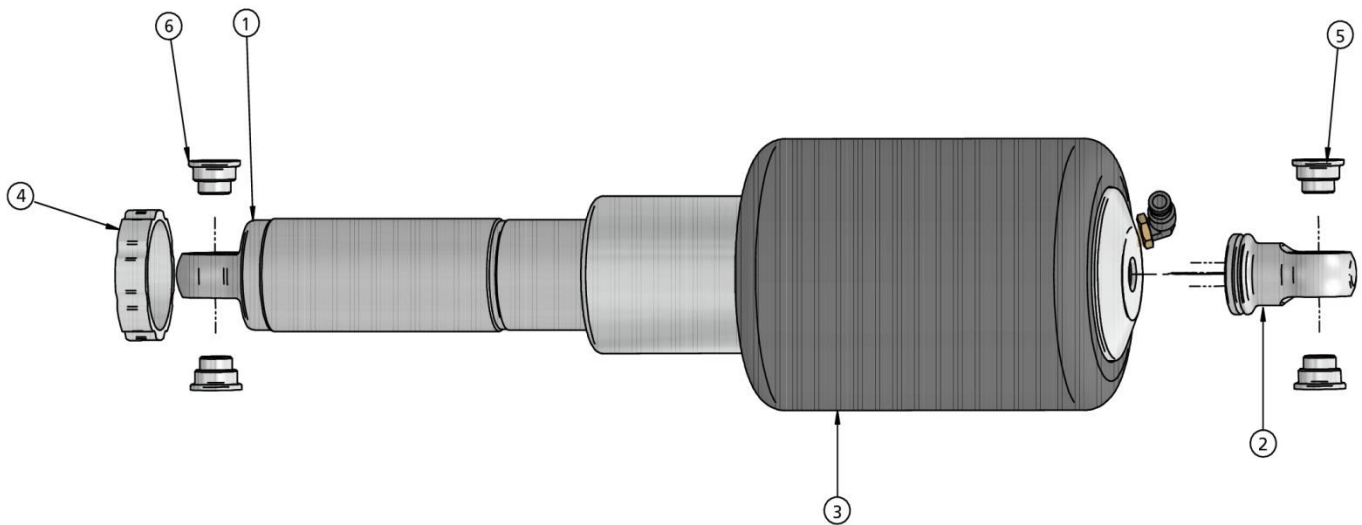

WARNING: ATTEMPTING TO REMOVE THE AIR FITTING WILL DAMAGE IT AND VOID THE WARRANTY.



Notes and Care of your Shockwaves

NOTES:

WARNING: ATTEMPTING TO REMOVE THE AIR FITTING WILL DAMAGE IT AND VOID THE WARRANTY.

You can clock the airfitting location on the ShockWave by turning the AirSpring assembly of the shock. Make sure the fitting doesn't contact the frame.

When cutting the airline, use a razor blade. The cut needs to be a clean cut and square for the airline to seal properly.

The Locking ring on the shock is **NOT** adjustable. These rings are set at the factory to optimize the AirSpring stroke with the shock stroke.

The care and feeding of your new ShockWaves

1. Although the ShockWave has an internal bumpstop, **DO NOT DRIVE THE VEHICLE DEFLATED RESTING ON THIS BUMPSTOP. DAMAGE WILL RESULT.** The internal bumpstop will be damaged, the shock bushings will be damaged, and the vehicle shock mounting points may be damaged to the point of failure. This is a non warrantable situation.
2. Do not drive the vehicle overinflated or "topped out". Over a period of time the shock valving will be damaged, possibly to the point of failure. This is a non warrantable situation! If you need to raise your vehicle higher than the ShockWave allows, you will need a longer unit.
3. The ShockWave is designed to give a great ride quality and to raise and lower the vehicle. **IT IS NOT MADE TO HOP OR JUMP!** If you want to hop or jump, hydraulics are a better choice. This abuse will result in bent piston rods, broken shock mounts, and destroyed bushings. This is a non warrantable situation.
4. Do not let the ShockWave bellows rub on anything. Failure will result. This is a non warrantable situation.
5. The ShockWave product has been field tested on numerous vehicles as well as subjected to many different stress tests to ensure that there are no leakage or durability problems. Failures have been nearly nonexistent unless abused as described above. If the Shockwave units are installed properly and are not abused, they will last many, many years. ShockWave units that are returned with broken mounts, bent piston rods, destroyed bumpstops or bushings, or abrasions on the bellows will not be warrantied.



Shock Adjustment

Shock adjustment 101- Single Adjustable

Rebound Adjustment:

How to adjust your new shocks.

The rebound adjustment knob is located on the top of the shock absorber protruding from the eyelet.

You must first begin at the ZERO setting, then set the shock to a soft setting of 20.



-Begin with the shocks adjusted to the ZERO rebound position (full stiff). Do this by rotating the rebound adjuster knob clockwise until it stops.



-Now turn the rebound adjuster knob counter clock wise 20 clicks. This sets the shock at 20. (settings 21-24 are typically too soft for street use).

Take the vehicle for a test drive.



-if you are satisfied with the ride quality, do not do anything, you are set!

-if the ride quality is too soft increase the damping effect by rotating the rebound knob clock wise 3 clicks. **CONTINUE ON NEXT PAGE.**

Take the vehicle for another test drive.



-if the vehicle is too soft increase the damping effect by rotating the rebound knob clock wise 3 additional clicks.



-If the vehicle is too stiff rotate the rebound adjustment knob counter clock wise 2 clicks and you are set!

Take the vehicle for another test drive and repeat the above steps until the ride quality is satisfactory.

Note:

One end of the vehicle will likely reach the desired setting before the other end. If this happens stop adjusting the satisfied end and keep adjusting the unsatisfied end until the overall ride quality is satisfactory.

STILL HAVE QUESTIONS?

Tech line hours

Monday - Friday

8AM - 6PM (EST) 812-482-2932

www.ridetech.com
812-482-2932