



**Part # 11170297 - 1970-1981 GM "F" Body ShockWave System**

**Recommended Tools**

**Front Components:**

- 11179599 Front TruTurn System
- 11173001 Front ShockWave Instructions
- 11179120 Front SwayBar Instructions

**Rear Components:**

- 11177150 Rear 4Link System
- 21150701 Rear ShockWave Instructions

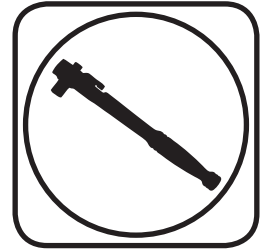

**1970-1981 GM "F" Body ShockWave  
Installation Instructions**

**Table of contents**

- Pages 2-11..... Front TruTurn System
- Pages 12-15..... Front ShockWaves
- Pages 16-18..... Front MuscleBar
- Pages 19-48..... Rear 4 Link System
- Pages 59-52..... Rear ShockWaves

**The OEM Front Brakes will not work with this kit.**  
(See Page 7 for details)

**www.ridetech.com**  
**812-482-2932**





### Part # 11179599 - 1970-1981 GM F-Body Front TruTurn System

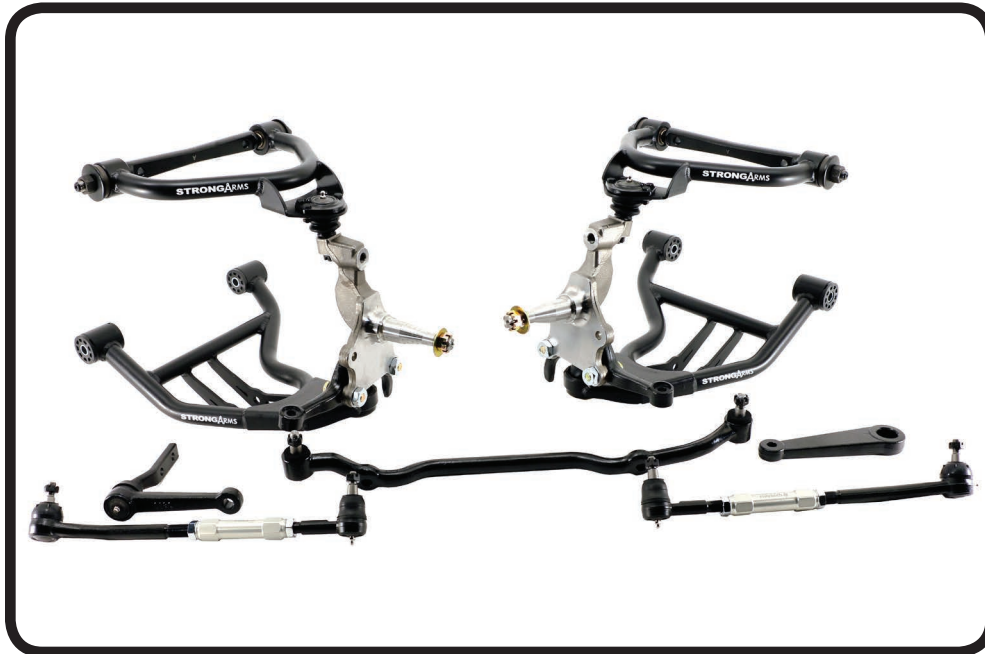

#### Recommended Tools

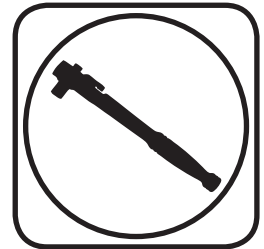

## 1970-1981 GM F-Body TruTurn System Installation Instructions

### Table of contents

Page 3.....	Included components
Page 4.....	Upper Control Arm Components
Page 5.....	Lower Control Arm Components
Page 6.....	TruTurn Steering Components
Page 7.....	Getting Started
Page 8.....	Installing Lower and Upper Control Arm
Page 9.....	Installing Spindles and Steering Arms
Page 10.....	Tie-Rod Assembly and Installation
Page 11.....	The Finish

The OEM Front Brakes will not work with this kit.  
(See Page 7 for details)





### Major Components .....In the box

Item #	Part #	Description	QTY
1	90002832	Driver Upper Control Arm	1
1	90002833	Passenger Upper Control Arm (Not Shown)	1
2	90002830	Driver Lower Control Arm	1
2	90002831	Passenger Lower Control Arm (Not Shown)	1
3	11009300	Tall Spindle (Driver and Passenger)	1pr
4	90003000	Steering Arm - 1 Set - includes driver and passenger	Set
5	90002836	Tie-Rod Adjuster	2
6	90002834	Tall Outer Tie Rod End	2
7	90009932	Steering Arm Tapered Nut	2
8	99501010	1/2"-20 x 2 1/4" Hex Bolt	2
9	99502005	1/2"-20 x 2" Hex Bolt	2
10	99800002	5/8" SAE RH Jam Nut	2
	99800001	11/16" SAE LH Jam Nut	2
	90003036	Center Link - (Not Shown)	1
	90003025	Left Inner Tie Rod - (Not Shown)	1
	90003026	Right Inner Tie Rod - (Not Shown)	1

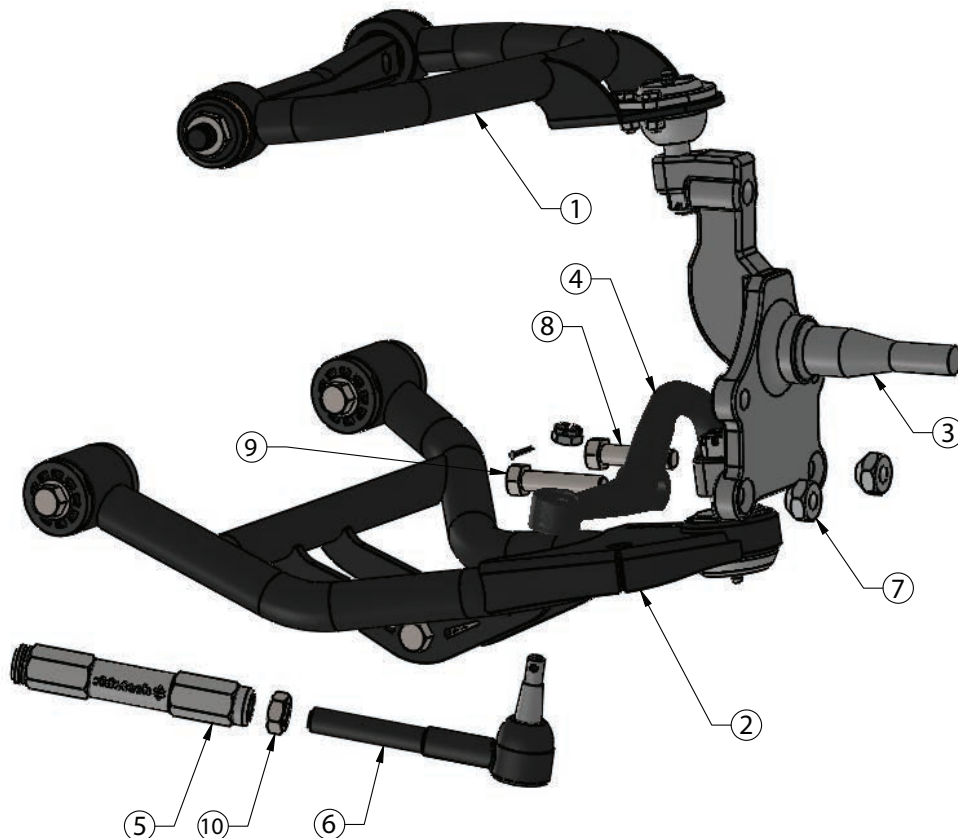



### Upper Control Arm Components .....In the box

Item #	Part Number	Description	QTY
1	90000894 Kit	Upper Balljoint Assembly	2
2	90002832	Driver Upper Control Arm <b>(Shown)</b>	1
2	90002833	Passenger Upper Control Arm	1
3	70012819	Delrin Control Arm Bushing	4
4	90002661	Delrin Bushing Inner Sleeve	4
5	90000917 kit	Upper Cross Shaft Kit	2
6	90000917 kit	5/8" Bushing Washer - included with 90000917	4
7	90000917 kit	5/8"-18 Locking Nut - included with 90000917	4

Driver Side Shown

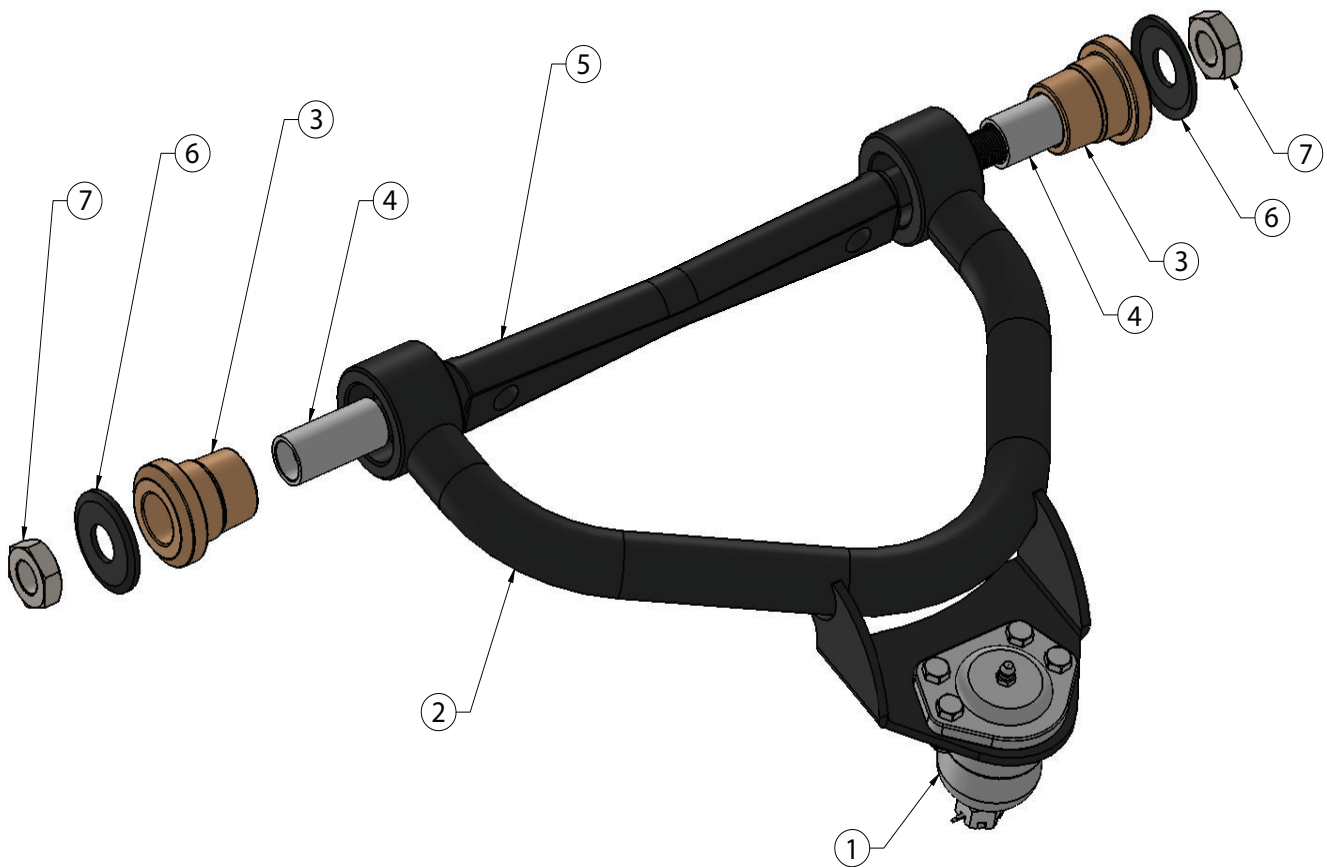





### Lower Control Arm Components .....In the box

Item #	Part Number	Description	QTY
1	90002830	Driver Lower Control Arm <b>(Shown)</b>	1
1	90002831	Passenger Lower Control Arm	1
2	90000898	Lower Balljoint Assembly	2
3	70010759	Delrin Bushing - with 2" Diameter Ledge	8
4	90002062	CoilOver Bearing Spacers	4
5	90000516	1/2" ID Inner Sleeve	4
5	90000517	9/16" ID Inner Sleeve	4
6	99501005	1/2"-13 x 3 1/2" Hex Bolt	4
7	99502009	1/2"-13 Nylok Nut	6
8	99503014	1/2" SAE Flat Washer	10
6	99561010	9/16"-12 x 3 1/2" Hex Bolt	4
7	99562006	9/16"-12 Nylok Nut	4
8	99563002	9/16" SAE Flat Washer	8
9	99501006	1/2"-13 x 3 1/2" Hex Bolt	2
10	99311011	5/16"-18 x 1 1/4" Hex Bolt	2
11	99312007	5/16"-18 Hex Nut	2

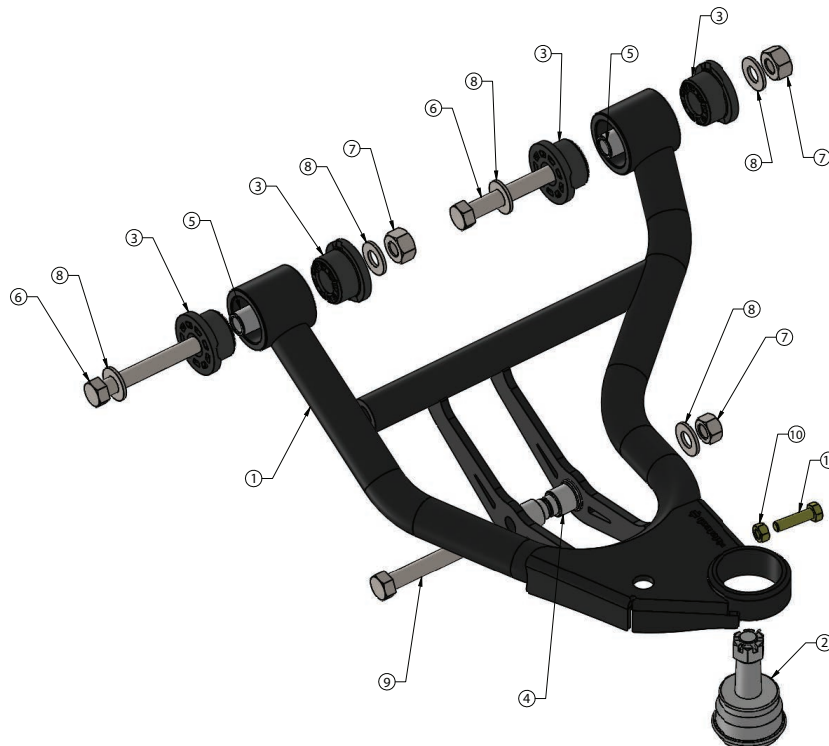

Driver Side Shown



### TruTurn Steering Components .....In the box

Item #	Part Number	Description	QTY
1	11009300	Ridetech Tall Spindle	1pr.
2	90003000	Driver Steering Arm	set
2	90003000	Passenger Steering Arm (not shown)	set
3	90003036	Center Link (not shown)	1
4	90002836	Tie-Rod Adjuster	2
5	90003025	Left Inner Tie Rod End (not shown)	1
5	90003026	Right Inner Tie Rod End (not shown)	1
6	90002834	Tall Outer Tie Rod End	2
7	90009932	Tapered Steering Arm Attaching Nut	4
8	90002835	Pitman Arm	1
9	90003007	Idler Arm	1
10	99502005	1/2"-20 x 2" Hex Bolt	2
11	99501010	1/2"-20 x 2 1/4" Hex Bolt	2
12	99800002	5/8"-18 RH Jam Nut	2
13	99800001	1 1/16"-16 LH Jam Nut	2
	99431023	7/16"-14 x 1 3/4" Hex Bolt GR 8 - Idler Arm	2
	99433005	7/16" SAE Flat Washer GR8 - Idler Arm	4
	99432010	7/16"-14 Nylok Nut GR8 - Idler Arm	2

Driver Side Shown

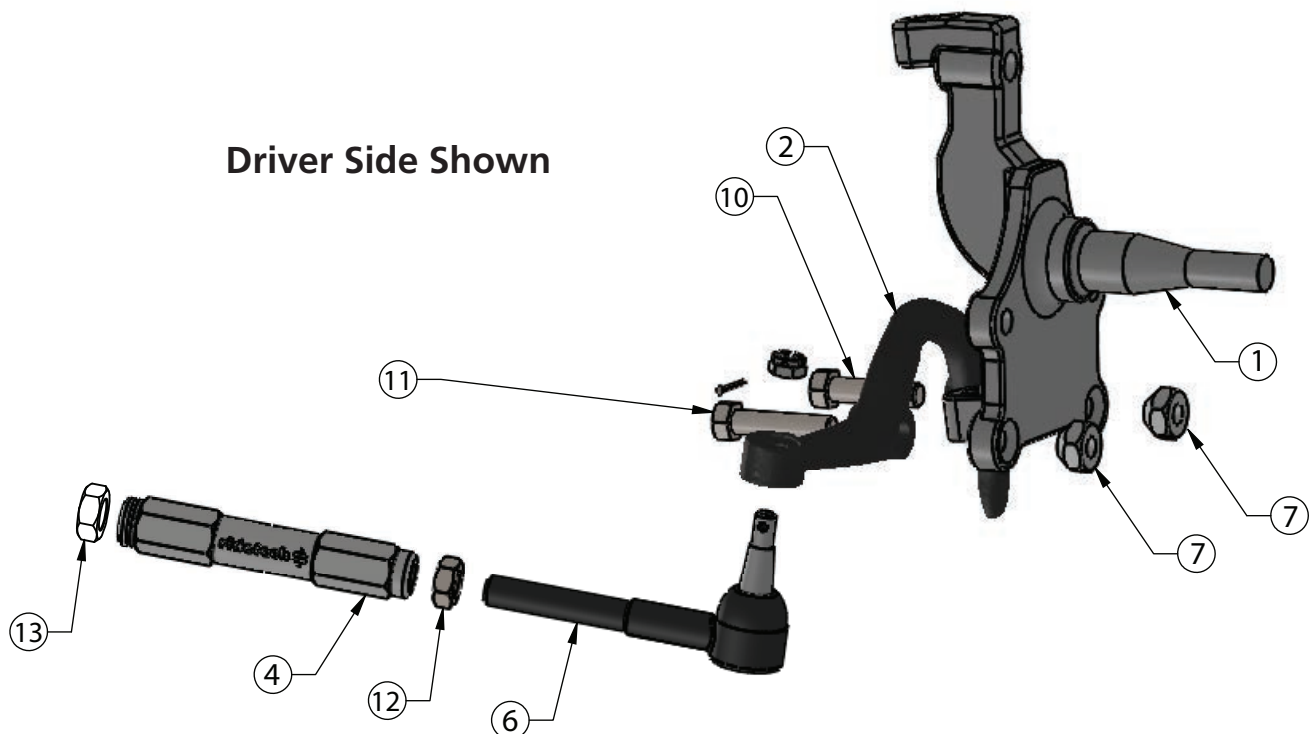



### Getting Started.....

Congratulations on your purchase of the Ridetech TruTurn System. This System have been designed to give your Camaro excellent handling along with a lifetime of enjoyment. Some of the key features of the TruTurn System: Balljoint angles have been optimized for the lowered ride height, Delrin bushings are used to eliminate bushing deflection along with providing free suspension movement through the entire travel. The Geometry has been optimized for excellent handling, driveability and minimal bumpsteer. The Delrin bushings are made from a material that is self lubricating so no grease zerks are needed.

**Note:** These control arms are designed for use with the Ridetech CoilOvers and the MuscleBar swaybar. **The factory shocks and springs or the factory sway bar will not fit these arms.**

**Note:** The Camaro TruTurn Suspension package uses a GM Spindle used on 67-69 F body, 64-72 A body, and 68-74 X body. Any Brake Kit designed to fit the OEM Disc Brake Spindle of the listed cars will fit the Spindle in your TruTurn System

**When assembling the Control Arms tighten the cross shaft nuts enough to create drag on the delrin bushings, the arm should still move through its travel by hand.**

### Installation

1. Remove the entire front suspension from the car including the centerlink, idler arm, and pitman arm. Refer to a Factory Service Manual for the proper method. The Control Arms, Spindles, and all the Steering Linkage will all be replaced with the TruTurn package.
2. Drill the factory upper shock mounting hole to 3/4". This can be done easily with a Unibit.



3. After removing the factory lower control arm, clean the bushing mounting surfaces on the frame. The Control Arms are marked "D" for Driver and "P" for Passenger. The Balljoint Pin points up and the Sway bar mount is on the front side of the arm. Fasten the lower arm to the frame with the hardware supplied. There are two different size bushing sleeves supplied 1/2" and 9/16". '71-'74 model years will use 1/2". '75-'81 will use 9/16".

Note: On some cars the frame brackets may be pinched and will need to be spread back apart to allow the bushing to slide in.



### Installing Lower & Upper Control Arm

**Install the CoilOvers at this time. Refer to the CoilOver instructions for Assembly.**

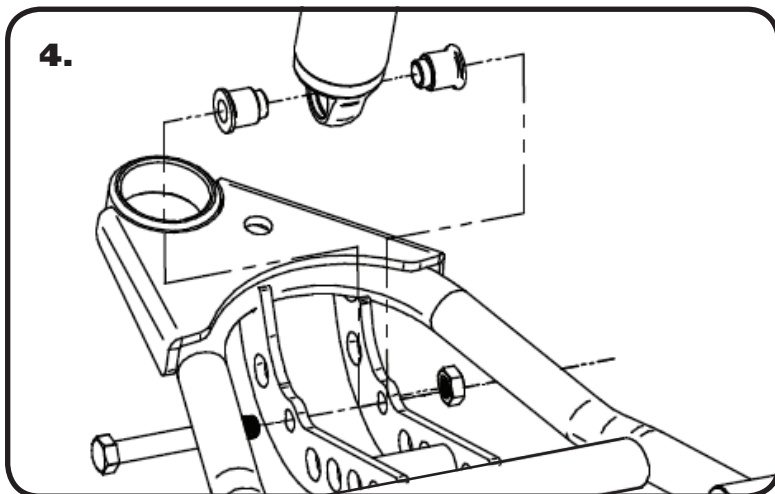

4. Insert the Bearing Spacers into the lower shock bearing. Swing the Control Arm up, line up the 1/2" holes with the bearing spacers, insert 1/2"-13 x 3 1/2" bolt. Install a 1/2" flat washer and nylok nut.



5. The Upper Control Arm is attaching the factory mount using factory hardware. The driver side arm is shown in Figure "5". The Balljoint located on the arm to the rear of the car.

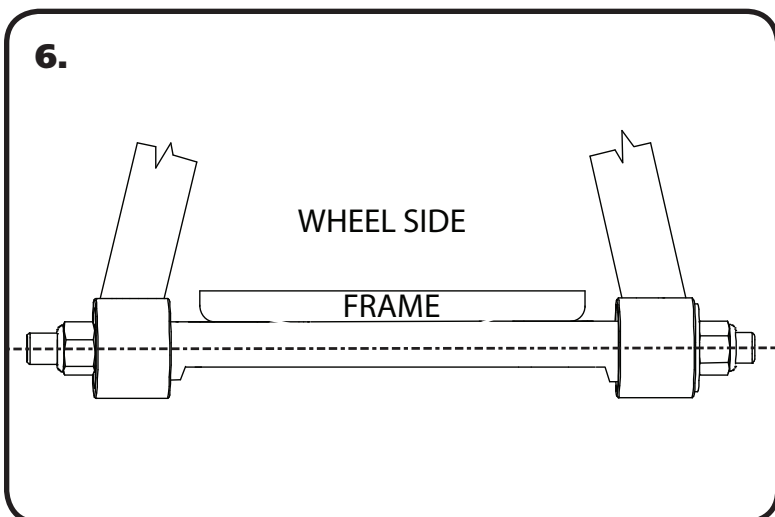

6. Attach the Upper Control Arm with the FLAT Side of the cross shaft against the frame. Attach the upper control arms using the OEM hardware.



### Installing Spindle and Steering Arm

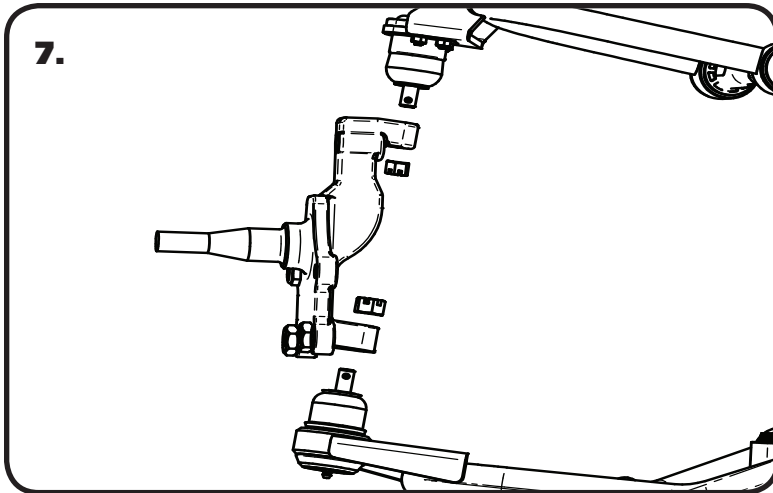

7. Attach the Spindle to the control arms. The Spindle is the same for Driver and Passenger.

**Torque Specs:**

Lower Balljoint - 65 ftlbs and tighten to line up cotter pin.

Upper Balljoint - 50 ftlbs and tighten to line up cotter pin.

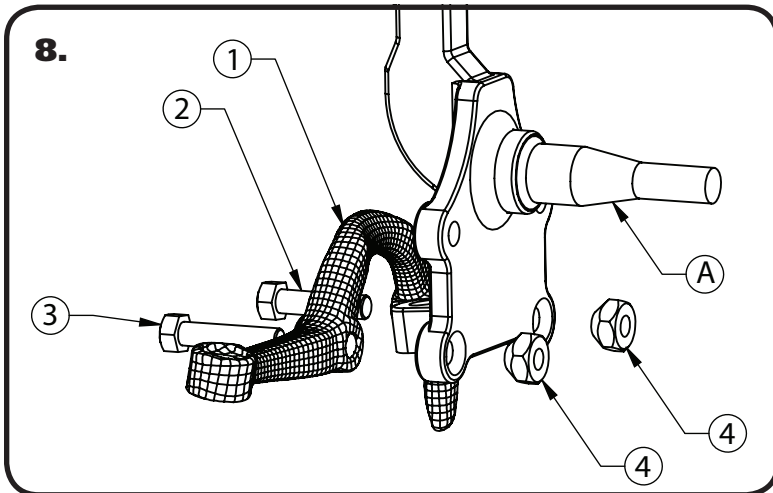

8. Attach Steering Arm(1) to Spindle(A). 1/2" x 2"(2), 1/2"x 2 1/4"(3) Hex Bolts, & Tapered Nuts(4) are used to attach them. The Steering Arm is positioned with the Tie Rod End pointing to the front of the car and toward the engine. Use Red Loctite (Supplied in the Kit) on the Bolts for the Tapered Nuts and Torque to 75 ftlbs.



9. The TruTurn kit includes a new centerlink, pitman arm, idler arm. All of these components must be replaced to optimize the suspension. A pitman arm puller is necessary to replace the pitman arm.





### Tie Rod Assembly and Installation

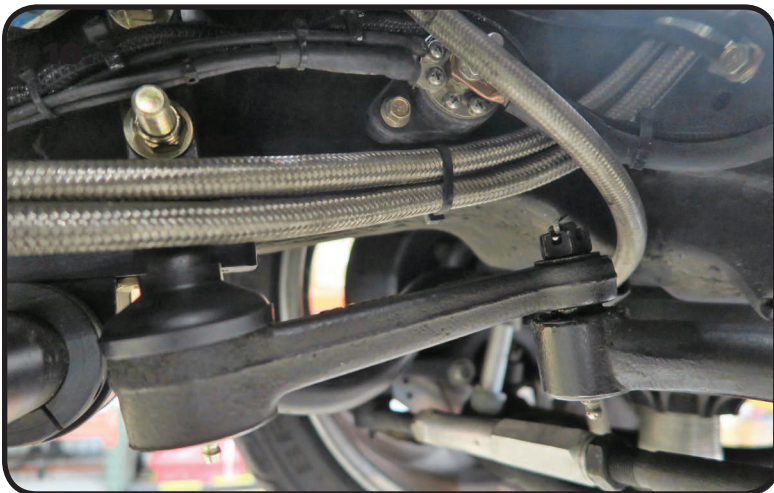

**10.** Early Cars(70-72) used 3/8" bolts to attach the Idler Arm, these will need the holes drilled to 7/16". New 7/16"-14 x 1 3/4" Bolts, 7/16" Flat Washers, & 7/16"-14 Nylok Nuts are supplied to attach the new Idler Arm.

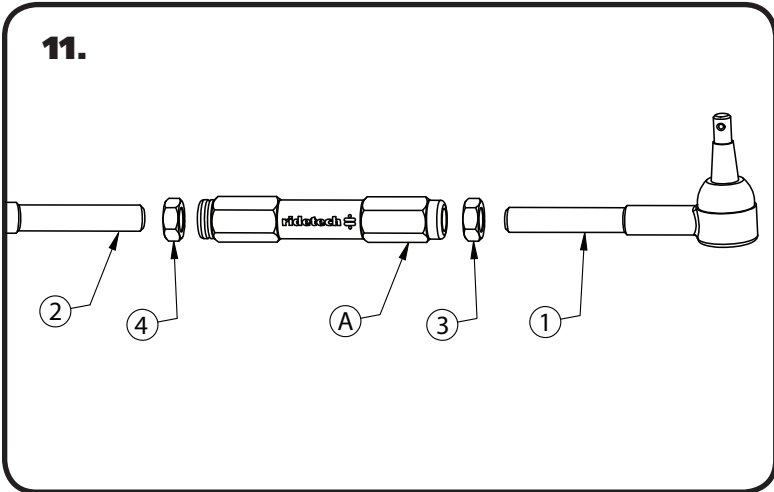

**11.** The Tie Rod Adjuster has 2 threads in it; 5/8-18 RH & 11/16-16 LH. The 11/16-16 LH thread is for the inner tie rod and is marked with a groove on the outside of the adjuster. Thread a 11/16"-16 LH Jam Nut on each of the inner Tie Rods. Thread a 5/8-18 RH Jam nut on each of the outer Tie Rods. Apply Antiseize to the threads of the adjuster. Thread the adjuster onto the inner tie rod, then thread the outer tie rod into the adjuster. You can keep the thread engagement by starting the inner and outer tie rods the same number of revolutions, then hold the outer tie rod from turning while turning the adjuster to thread it on the tie rods. This will thread them in evenly.

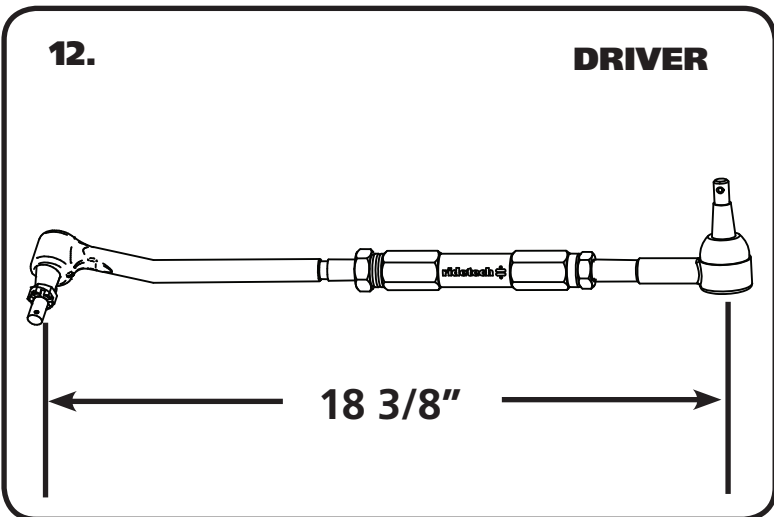

**12.** Assemble the Tie-Rod to a center to center length of 18 3/8" to start with, having equal amount of thread engagement on both ends. Use anti-seize on the threads of the Tie Rod and Heim end before threading them into the adjuster. The kit includes a Driver and Passenger Inner Tie Rod. The Tie Rods are installed with the BEND to the BOTTOM for better frame clearance. The Driver side is shown in **Image 11**.



### Finishing

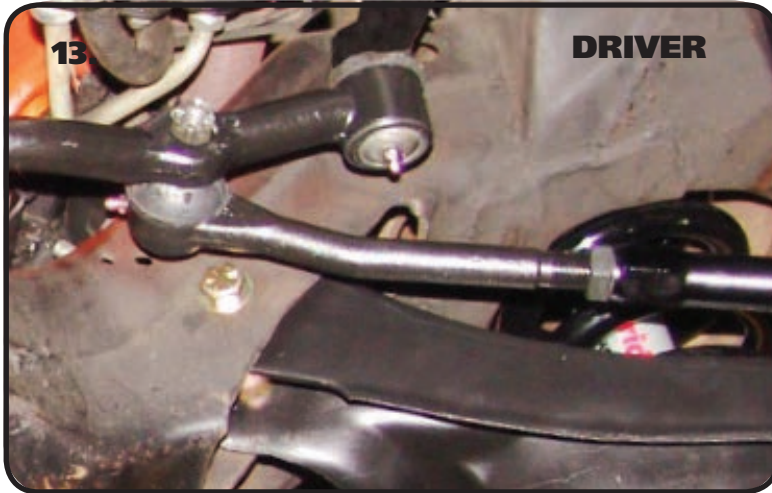

**13.** Install Inner Tie Rod into Centerlink using a 7/16" Castle Nut and 3/32" Cotter Pin. Insert the tapered end of the tie rod into the taper of the centerlink. Thread the 7/16" Castle nut on the stud. Torque to 35 ftlbs and then tighten to align Cotter Pin hole with slot on Castle Nut. Install Cotter Pin. Make sure the correct inner tie rods are on the correct sides. The driver is shown in **Image 12**.

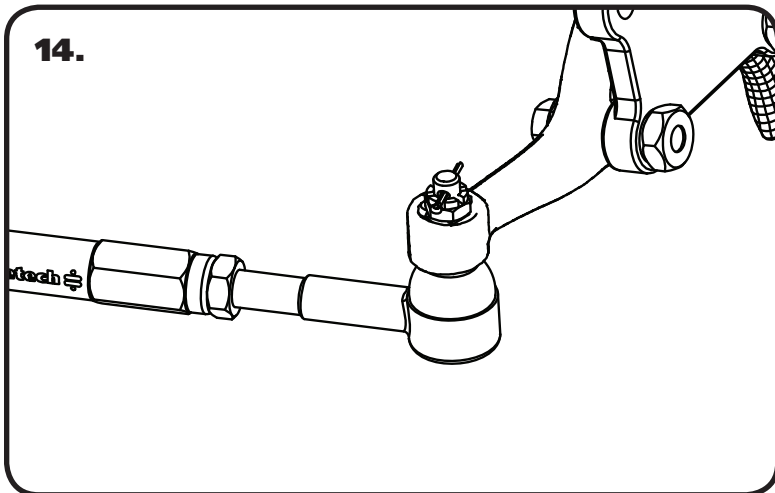

**14.** Install Outer Tie Rod into Steering Arm using a 7/16" Castle Nut and 3/32" Cotter Pin. Insert the tapered end of the tie rod into the taper of the steering arm. Thread the 7/16" Castle nut on the stud. Torque to 35 ftlbs and then tighten to align Cotter Pin hole with slot on Castle Nut. Install Cotter Pin.

**15.** Tighten all fasteners. If you are going to install the Ridetech MuscleBar, now is a good time to do it.

**When assembling the Control Arms tighten the cross shaft nuts enough to create drag on the delrin bushings, the arm should still move through its travel by hand.**

#### Suggested Alignment Specs:

Camber: Street: -.5 degrees  
Caster: Street: +3.0 to + 5.0 degrees  
Toe: Street: 1/16" to 1/8" toe in





**Part # 11173001 - 70-81 GM F-Body Front HQ Series Shockwave**

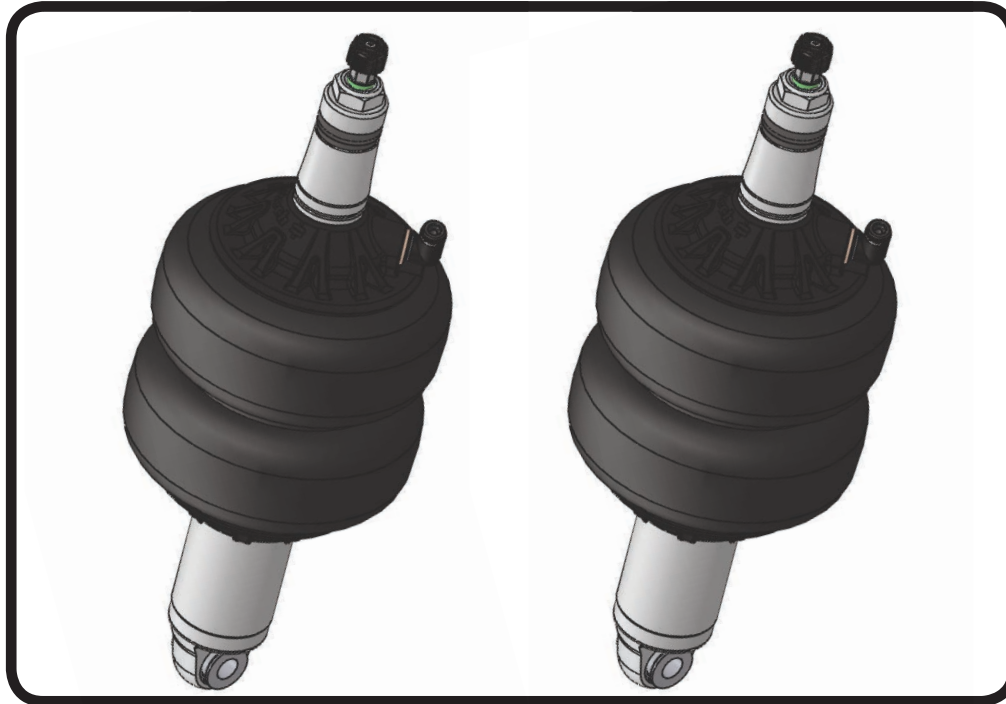

Recommended Tools

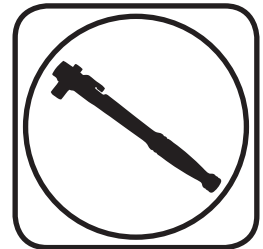

## 1000 Series Bellow, 2.75" Stud/Eye 3.6 " Shock Installation Instructions

### Table of contents

Page 13..... Included components

Page 14-15..... ShockWave installation

### ShockWave Dimensions:

Center of bearing to Center of bearing:

Compressed: 11.05"

Ride Height: 12.85"

Extended: 14.05"

THE DELRIN BALL REQUIRES A 3/4" HOLE FOR THE FLANGE TO GO THROUGH. THIS CAN BE DRILLED WITH A UNIBIT.





### Major Components .....In the box

Item #	Part #	Description	QTY
1	24139999	3.6" Stroke HQ Series Shock	2
2	90009989	2.75" Stud Top (Installed on Shock) - Includes Adjuster Knob & Screw	2
3	24090199	1000 Series 6.5" Double Convoluted AirSpring	2
4	70008193	AirSpring Locking Ring (Installed on shock)	2
5	99055000	Locking Ring Set Screw (Installed on shock)	2
6	90002062	Spacers - INCLUDED WITH STRONGARMS	4
7	90002313	2.75" Aluminum Stud Top Base	2
8	90001904	Bottom Delrin Ball	2
9	90001903	Top Delrin Ball	2
10	90001902	Delrin Ball Aluminum Top Cap	2
11	99562003	9/16" -18 Thin Nylok Nut	2
12	90009972	Adjuster Knob - (90009989 assembly)	2
13	90009969	#4-40 X 1/4" SS, 18-8 Pan Head Torx Cap - (90009989 assembly)	2
	70012161	2.75" Stud Top Metering Rod (installed in stud top)	2
	90001994	5/8" ID Bearing (installed in shock and eyelet)	4
	90001995	Bearing Snap Ring (installed in shock and eyelet)	8

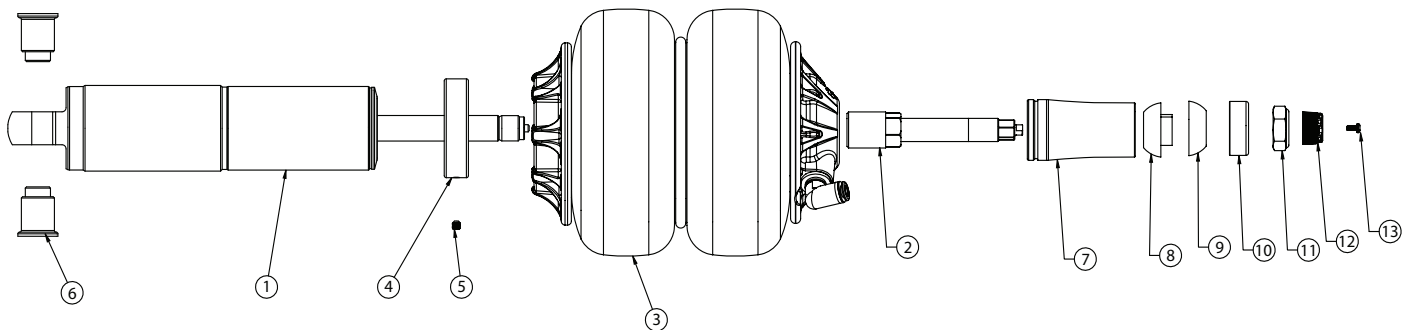

**THE DELRIN BALL REQUIRES A 3/4" HOLE FOR THE FLANGE TO GO THROUGH. THIS CAN BE DRILLED WITH A UNIBIT.**

**WARNING: ATTEMPTING TO REMOVE THE AIR FITTING WILL DAMAGE IT AND VOID THE WARRANTY.**



### ShockWave Installation

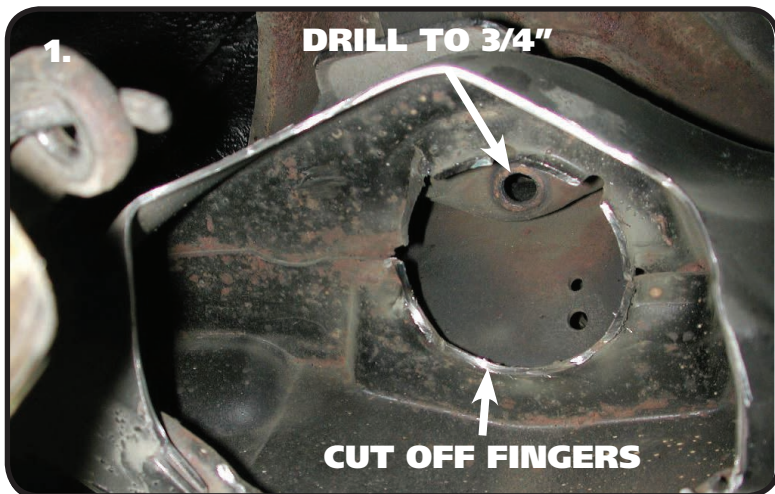

1. Drill the OEM shock hole out to 3/4". This can be done with a Unibit. The Shockwave top will come in contact with the coil spring retaining fingers, they must be cut off. A die grinder works well here.



2. Some trimming must also be done on the outside of the frame pocket to allow clearance for the Shockwave.

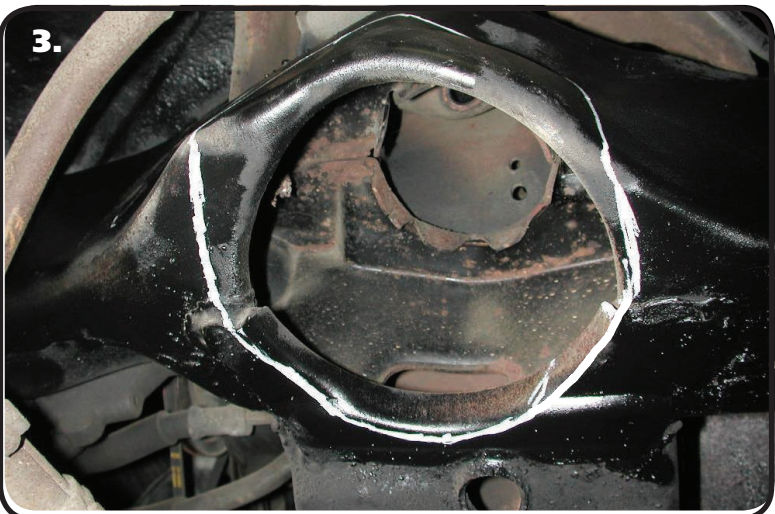

3. To allow clearance for the Shockwave, some trimming must be done on the inside of the coil spring pocket as shown by the white line in the picture. This is best done with either a cut off wheel or plasma cutter. Grind all cuts smooth when finished.

**Note:** It may be helpful to go ahead and install the lower StrongArms and Shockwaves to determine exactly what needs to be removed.



### ShockWave Installation

4.

1. Stud top aluminum base
2. Delrin ball lower half
3. Delrin ball upper half
4. Aluminum cap
5. 9/16" SAE Nylok jam nut
6. Threaded stud (screwed onto shock shaft)
7. Rebound adjusting knob
8. Screw

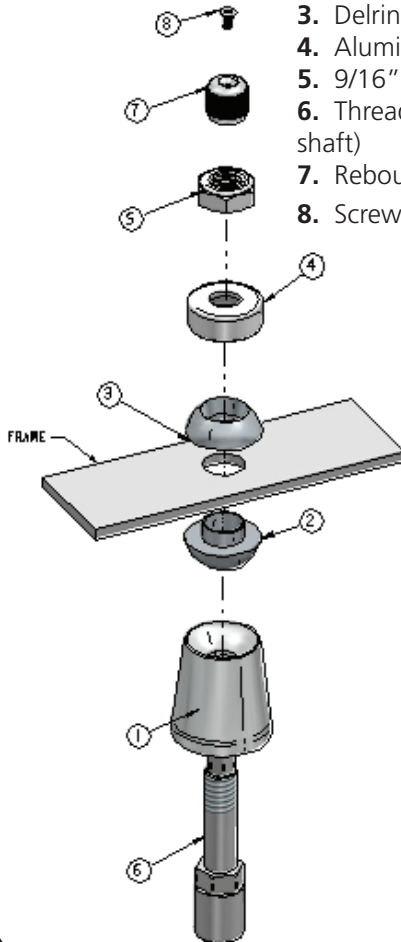

**Note:** The airline must also be routed at this time. It can be ran through the subframe toward the rear of the vehicle.

4. The air fitting location can be rotated by twisting the bellow assembly separate of the shock. Place the Shockwave into the coil spring pocket with the stud sticking through the OEM shock hole. See assembly **Diagram 4**. OEM Shock hole **must** be drilled out to  $\frac{3}{4}$ "

1. Stud top aluminum base
2. Delrin ball lower half
3. Delrin ball upper half
4. Aluminum cap
5. 9/16" SAE Nylok jam nut
6. Threaded stud (screwed onto shock shaft)
7. Rebound adjusting knob
8. Screw

5.

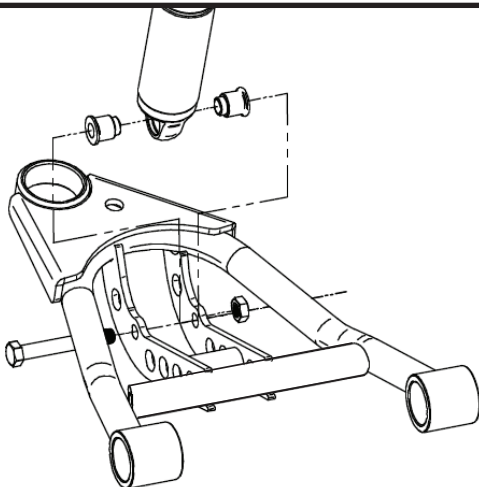

5. Raise the lower arm up to the Shockwave and bolt them together using the  $\frac{1}{2}$ " x  $3\frac{1}{4}$ " bolt and Nylok supplied w/ the lower arms. An aluminum spacer will be on each side of the bearing. Torque to 75 ftbs.

6. Raise the lower control arm to full compression and double-check to make sure the Shockwave does not rub on anything at any-time. Allowing the Shockwave to rub on anything will cause failure and is not a warrant-able situation.

7. The best ride quality will occur around 50-60% suspension travel; depending on vehicle weight this typically occurs around 85-100 psi.





### Part # 11179120 - 1970-1981 GM F-Body Front SwayBar

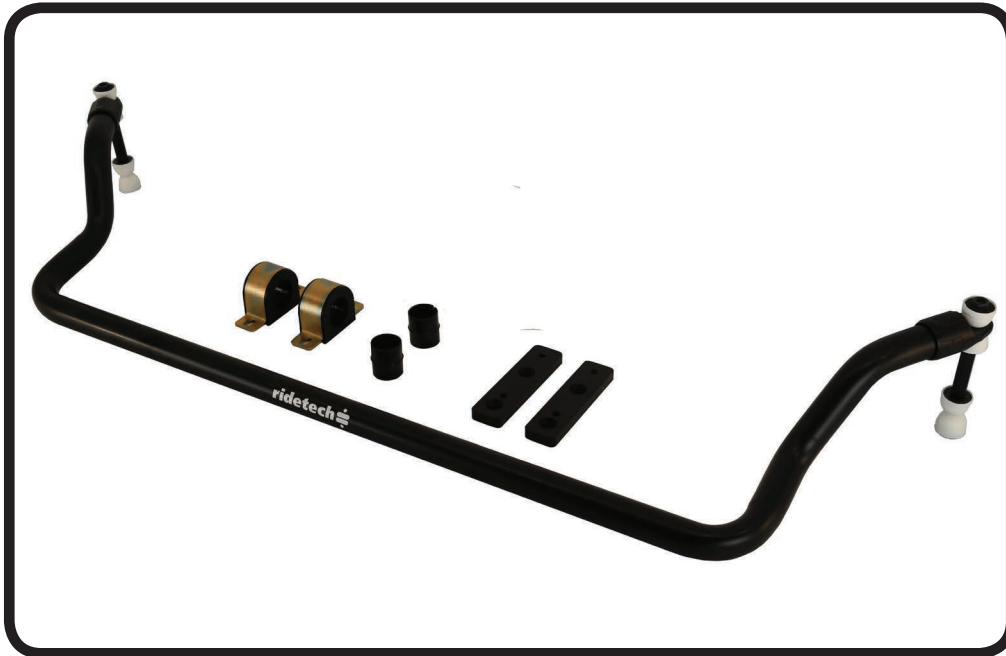

#### Recommended Tools

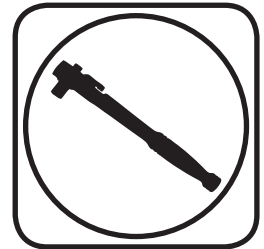

## 1970-1981 GM F-Body Front SwayBar Installation Instructions

#### Table of contents

- Page 17..... Included Components and Hardware List
- Page 18..... SwayBar Installation

#### Hardware Torque Specifications

- 5/16"-16..... 17 ftlbs
- 3/8"-16..... 30 ftlbs



# Major Components .....In the box

Part #	Description	QTY
90001226	Front SwayBar	1
90002933	End Link Kit	1
70012394	Delrin Sway Bar Bushing Liner	2
90002513	Bushing Strap	2
90001099	SwayBar Bushing	2
90001254	Bushing Mount Adapter	2

## HARDWARE KIT .....99010083

QTY	Part Number	Description
<b>ADAPTER PLATE</b>		
2	99371032	3/8"-16 x 1 1/4" Flat Head
2	99311025	5/16"-18 x 1 1/4" Flat Head
2	99371005	3/8"-16 x 1 1/4" Hex Bolt
2	99311011	5/16"-18 x 1 1/4" Hex Bolt
2	99373002	3/8" Flat Washer
2	99313001	5/16" SAE Flat Washer
2	99373006	3/8" Split Lock Washer
2	99313003	5/16" Split Lock Washer
1	90002263	Red Loctite

QTY	Part Number	Description
<b>BUSHING STRAP</b>		
4	99371065	3/8"-16 x 3/4" Hex Bolt
4	99373002	3/8" Flat Washer
4	99373006	3/8" Split Lock Washer

## Getting Started.....

This SwayBar Kit utilizes a Delrin Liner in the SwayBar Bushing. The Delrin Liner allows the SwayBar to move freely and quietly in the Bushing. The Delrin is self-lubricating, no lubrication is required.

**Note: The threaded holes in the frame can be either 5/16"-18 or 3/8"-16. Hardware is supplied for both.**

1. Jack the vehicle up to a safe working height and support with jack stands. Make sure the jack stands are stable before working under the car.
2. Remove the stock sway bar.
3. After removing the stock sway bar, determine what size hardware the frame will require.



**4.** Open the Delrin Liner at the split and slip it over the SwayBar. Position it in the area that the bushing will ride based on the location of the stock swaybar. Do this on both ends of the swaybar.



**5.** Open the SwayBar Bushing at the split and slide it **OVER** the Delrin Liner. Do this on both Delrin Liners.



6.

6. Slip the Bushing Straps over the SwayBar Bushings.

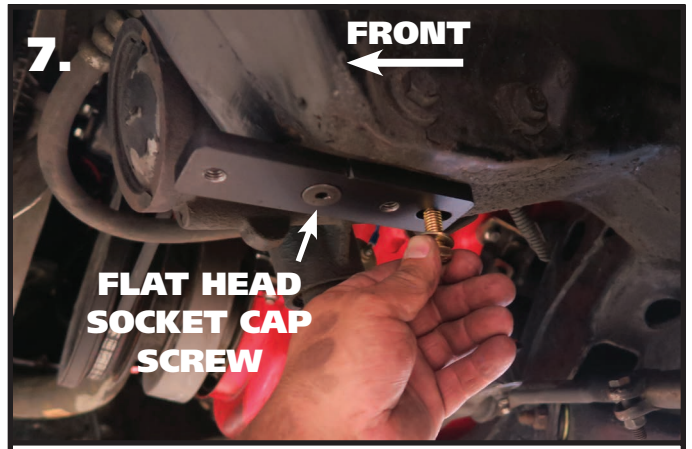

7.

FLAT HEAD  
SOCKET CAP  
SCREW

7. Hold the Frame Plate up to the OEM holes, the Counter Sunk hole will be positioned over the front hole with the slot to the rear. Apply Red Loctite to the Flat Head Bolt. The rear 1 1/4" long bolt uses a Split Washer and Flat Washer. Torque Hardware.



8.

8. Slide the SwayBar into position on the car with the SwayBar arms above the tie rods. Install a 3/8" Lock Washer & 3/8" Flat Washer on the 3/8"x 3/4" Hex Bolts. Do **NOT** Complete tighten the Hardware, it will be left partially loose until the End Links are installed.

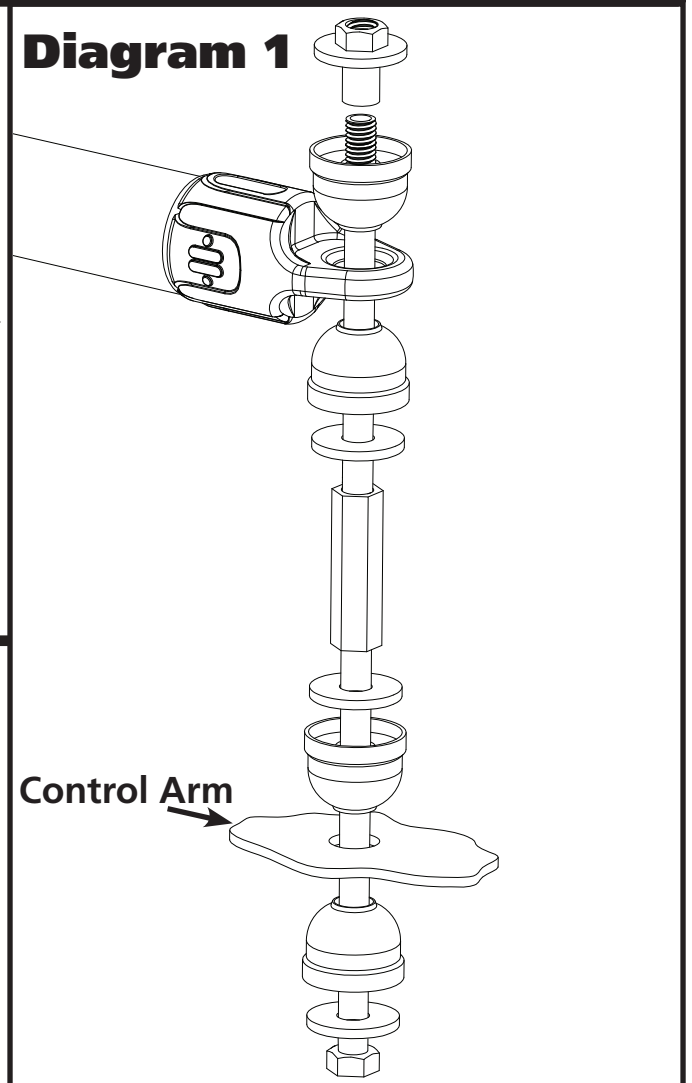

Diagram 1

Control Arm



9

9. Install the End Links using **Diagram 1** as a reference. Install both end links before tightening the end link hardware. Tighten the end link barrel nut until it is flush with the end of the bolt, and then tighten it 2 more complete rounds.

10. Torque the SwayBar mounting hardware to 30 ftlbs.





**Part # 11177150 -1970-1981 GM "F" Body Rear Bolt-in 4 Link**

### Recommended Tools

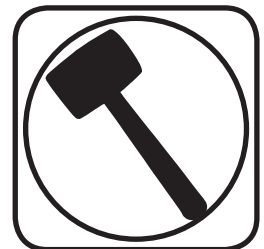
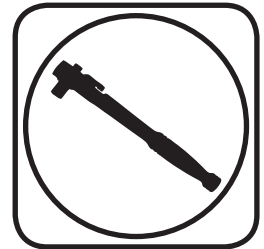
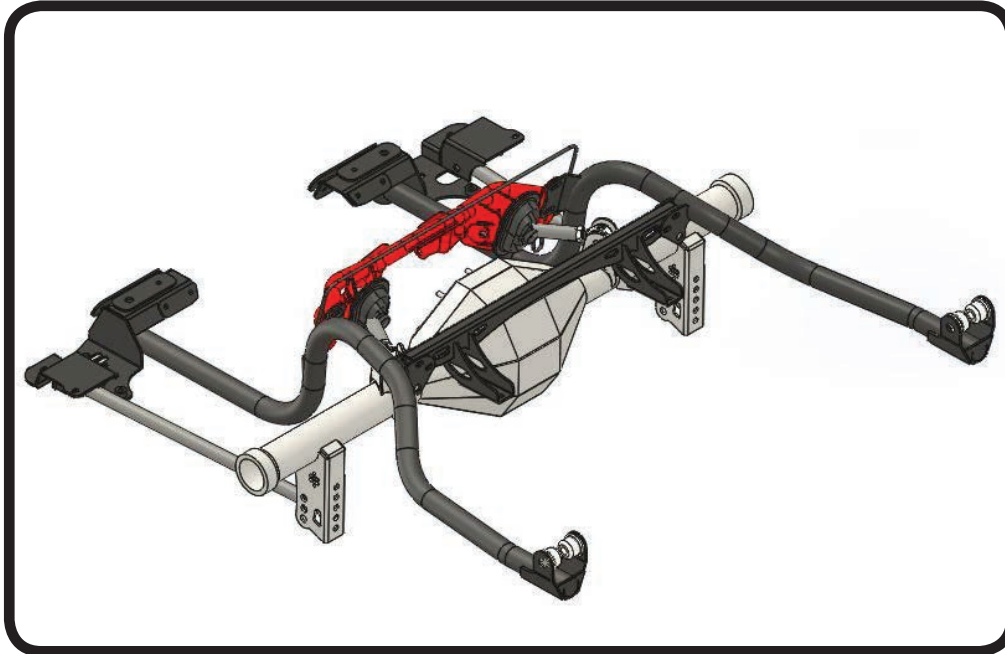

## 1970-1981 GM "F" Body Rear Bolt-in 4-Link Installation Instructions

### Table of contents

Page 20-21.....	Included Components
Page 22.....	Hardware List
Page 23-25.....	Disassembly
Page 26-27.....	Front Lower Bar & Subframe Mount Installation
Page 28-29.....	Subframe Installation
Page 30-32.....	Upper Bulkhead Installation
Page 33.....	Using Template
Page 34-37.....	Cutting Upper Bar Holes
Page 35.....	Installing Lower 4 Link Bars
Page 36 .....	Installing Lower Axle Mounts
Page 37 .....	Attaching Lower 4 Link Bars to Differential
Page 38 .....	Setting Pinion Angle
Page 39 .....	Upper 4 Link Bar Installation
Page 40-41.....	Upper Bar Tab Installation
Page 42-43.....	Installing Upper 4 Link Bars
Page 43.....	Shock Crossmember Installation
Page 44.....	Installing Lower Shock Mount
Page 44-45.....	Installing ShockWaves/CoilOvers
Page 46-48.....	Rear Seat Modification





### Major Components .....In the box

Item #	Part #	Description	QTY
1	90002785	Subframe Rail - Driver	1
2	90002786	Subframe Rail - Passenger	1
3	90002787	Rear Frame Bushing	4
4	90002788	Lower Bar Front Frame Bracket - Driver	1
5	90002789	Lower Bar Front Frame Bracket - Passenger	1
6	90002790	Lower Bar Front Frame Bracket Inner Reinforcing Plate - Front	2
7	90002791	Lower Bar Front Frame Bracket Inner Reinforcing Plate - Top	2
8	90002792	Lower Bar Front Frame Bracket Inner Reinforcing Plate - Rear	2
9	90002802	Front Frame Bracket Spacer	2
10	90002793	Upper 4 Link Bar Front Bulkhead	1
11	90002794	Front Bulkhead Reinforcing Plate	1
12	90002795	Upper Bar Adjustment Washer	4
13	90002796	Rear Shock Crossmember	1
14	90002797	Upper 4 Link Bar (9.250" center to center)	2
15	90002798	Lower 4 Link Bar (24.500" center to center)	2
16	90002771	Complete R-Joint - Installed in Upper Bars	2
17	70013442	Weld-On Lower Bar/Shock Mount	2
18	70013439	Upper Bar Tab	4
19	70013441	Axle Tab Rear Brace	2
20	90001617	Lower Shock Stud	2
21	90001624	Aluminum Lower Shock Mount	2
22	90002067	Lower Shock Spacers	4
23	70013554	Seat Frame Wire	1
24	70013618	Upper 4 Link Bar Rubber Boot	2
	70013655	2" Steel Loop, Rounded	10
	70013656	5/8" Hog Rings	12
	70013657	7/8" Hog Rings	12
	70013334	R-Joint Spacers	16
	70013675	Safety Wire	6
	70010694	Bar Tab Setting Jig	2
	Template	Upper Bar Hole Cutting Template	1

**New R-Joints will be quite stiff (75-90 in/lbs breakaway torque) until they "break in" after a few miles of use. After the break in period they will move much more freely. Because the composite bearing race contains self lubricating ingredients, no additional lubrication is needed or desired. Any additional lubrication will only serve to attract more dirt and debris to the R-Joint and actually shorten its life.**



### Major Components .....In the box

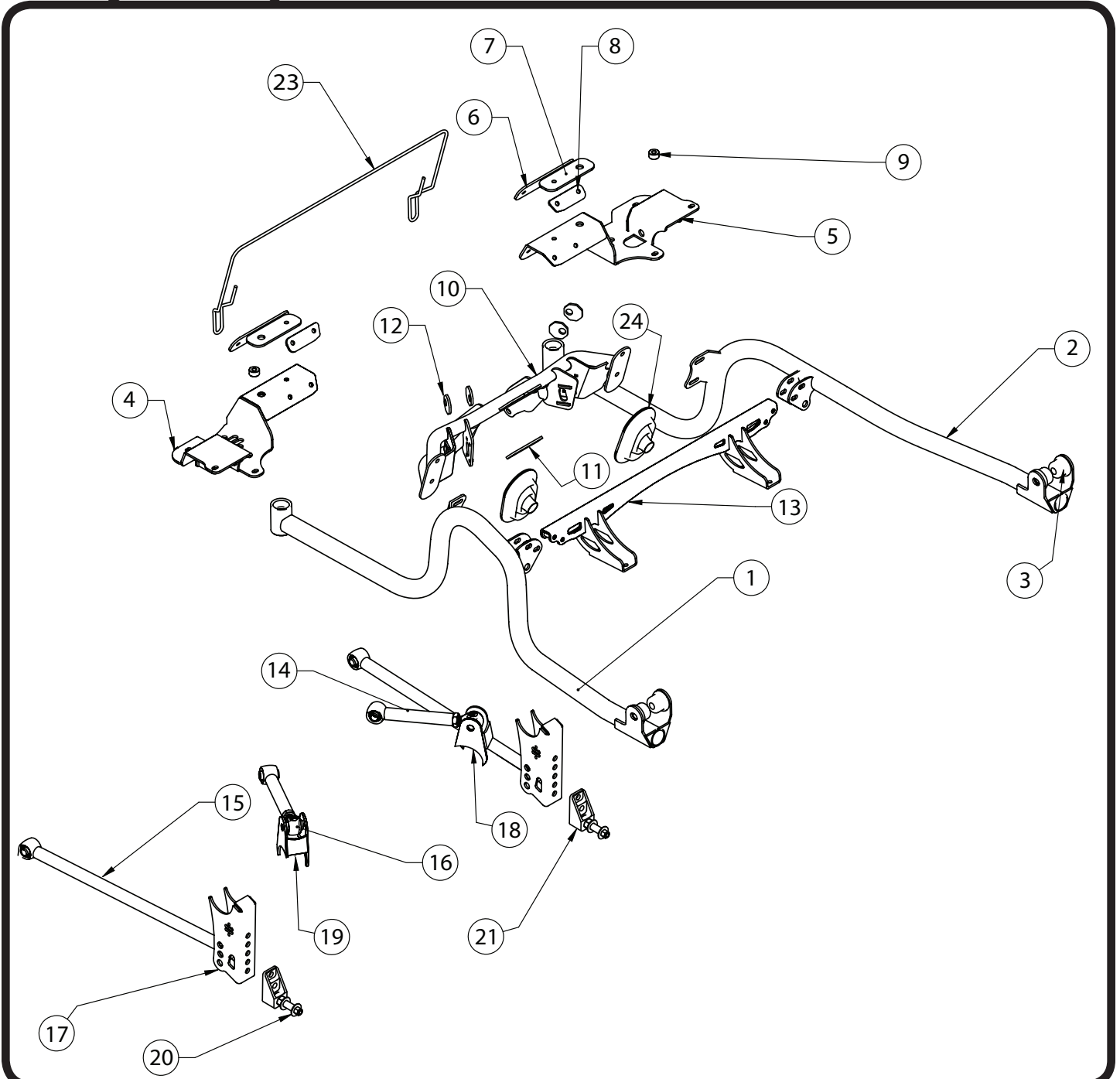

New R-Joints will be quite stiff (75-90 in/lbs breakaway torque) until they "break in" after a few miles of use. After the break in period they will move much more freely. Because the composite bearing race contains self lubricating ingredients, no additional lubrication is needed or desired. Any additional lubrication will only serve to attract more dirt and debris to the R-Joint and actually shorten its life.



### Hardware List .....In the box (Kit# 99010072)

The Hardware Kit contains bags to help aid in selecting the correct hardware for the component being installed. The hardware list shows how the hardware is bagged.

QTY	Part Number	Description	QTY	Part Number	Description
<b>LOWER BAR/SUBFRAME MOUNT</b>			<b>UPPER 4 LINK BARS</b>		
16	99371005	3/8"-16 x 1 1/4" Hex Bolt	2	99621004	5/8"x 3" Gr. 8 Bolt
12	99372001	3/8-16" Nylok Nut	2	99621005	5/8"x 3 1/2" Gr. 8 Bolt
30	99373002	3/8" SAE Flat washer	4	99622006	5/18"-18 Thin Nylok Nut
2	99371007	3/8"-16 x 1 1/2" Hex Bolt	8	99623010	5/8" SAE Flat Washer Gr. 8
6	99372009	3/8"-16 U-Nut	<b>LOWER 4 LINK BARS</b>		
<b>SUBFRAME MOUNTING</b>			2	99621004	5/8"x 3" Gr. 8 Bolt
2	99621024	5/8"-11 x 4 1/2" Gr. 8 Bolt	2	99621003	5/8"x 2 3/4" Gr. 8 Bolt
8	99623010	5/8" SAE Flat Washer Gr. 8	4	99622006	5/18"-18 Thin Nylok Nut
2	FULLY THREADED	5/8"-11 x 4 1/2" Gr. 8 Bolt	6	99623010	5/8" SAE Flat Washer Gr. 8
4	99622008	5/8"-11 Thin Nylok Nut	<b>UPPER SHOCK MOUNTING</b>		
<b>UPPER BAR BULKHEAD</b>			2	99621022	5/8"-18 x 2 1/2" Gr. 8 Bolt
6	99371005	3/8"-16 x 1 1/4" Hex Bolt	2	99622006	5/18"-18 Thin Nylok Nut
6	99372001	3/8-16" Nylok Nut	4	99623010	5/8" SAE Flat Washer Gr. 8
12	99373002	3/8" SAE Flat washer	<b>LOWER SHOCK MOUNT</b>		
2	99501062	1/2"-13 x 1 1/4" Hex Bolt	2	99501019	1/2"-13 x 1 1/4" Hex Bolt
2	99502001	1/2"-13 Nylok Nut	2	99501046	1/2"-13 x 1 3/4" Hex Bolt
4	99503014	1/2" SAE Flat Washer	4	99502001	1/2"-13 Nylok Nut
<b>UPPER SHOCK CROSSMEMBER</b>			4	99503001	1/2" SAE Flat Washer
4	99371052	3/8"-16 x 2 1/4" Hex Bolt	<b>BAR SETTING JIG</b>		
4	99372001	3/8-16" Nylok Nut	2	99371001	3/8"-16 x 3/4" Hex Bolt
8	99373002	3/8" SAE Flat washer	2	99372004	3/8"-16 Hex Nut

### Getting Started.....

Congratulations on your purchase of the Ridetech Rear 4-link System. This system has been designed to give your Camaro excellent handling along with a lifetime of enjoyment. This kit replaces the Leaf Springs, this allows the 4-Link to locate the rearend and the CoilOvers/ShockWaves to support the car. This allows each to be optimized for the best performance.

**Note:** These system is designed for use with the Ridetech Shockwaves or CoilOvers and the MuscleBar swaybar. **The factory shocks and springs will not fit this setup.**



### Disassembly

1. Raise the vehicle to a safe and comfortable working height. Use jack stands to support the vehicle with the suspension hanging freely.
2. Support the axle and remove the leaf springs, shocks, and tail pipes. If your car is equipped with a rear sway bar, it will also need to be removed. Disconnect the emergency brake cables and brake line from the differential. Plug or cap the rear brake line to keep debris out of the line and to keep from losing all the brake fluid from the rear line. Remove the rear differential, it will make it easier to cut the OEM leaf spring mounts off. Refer to the factory service manual for proper disassembly procedures. The back seat of the car will also need removed for installation of the some of the brackets. **If the rear brake line gets detached, you will need to bleed the rear brakes. You may need to redo the brake lines that are on the differential.**

The following steps show the removal of brackets, these can vary depending on the year of the car. Some years do NOT have some of the brackets shown. If your car doesn't have the particular bracket shown in a step, skip to the next step.



3. Disconnect the emergency brake cables from the main cable at the adjuster. It is located under the driver side rear foot well. After it is removed, disconnect the cables from the connector that joins the rear cables together. Set the hardware and connector aside, you will need them for reassembly.



4. Remove the retaining clips that hold the emergency brake cable in place.





### Disassembly



5. Remove the bracket on the outside of the frame that holds the emergency cable in place. This will allow the cable to be pulled out of the car. You do NOT need to remove the cables from the differential.



6. Remove the emergency brake cable bracket from the frame. You can do this by drilling out the spot welds or cutting it flush with the frame rails. We used a sawzall to remove them.



7. Cut the corner braces off that are located above the axle where the frame rail drops down. **Depending on the year of your car, it may not be equipped with these braces.** These can be removed by drilling the spot welds or cutting them of flush with the tabs.



### Disassembly



**8.** If your car has this style of exhaust bracket behind the axle, they will need to be cut off. Again, this can be done by drilling the rivets or cutting off flush with the tabs. The early cars have a different style of mount that doesn't need to be cut off.



**9.** Remove the U-joint straps from the yoke. Disconnect the driveshaft from the rear differential. It is a good idea to wrap masking tape around the end of the driveshaft to help keep the u-joint caps in place.



**10.** Unbolt the pinion snubber and remove it.





### Front Lower Bar & Subframe Mount Installation



**11.** Remove the rear shackle bushings from the frame on both sides of the car. Clean the hole to remove any debris that may be in the hole.



**12.** The front OEM leaf spring mount is attached to the body using u-nuts. New 3/18"-16 U-Nuts are supplied in the kit. Install the U-Nuts in place of the OEM u-nuts.



**13.** Insert a 3/8"-16 x 1 1/2" Hex Bolt in the rear hole of the Lower Bar/Subframe Mount. This needs to be inserted from the bottom with the threads sticking up. Install the Aluminum Spacer on the bolt.



### Front Lower Bar & Subframe Mount Installation



**14.** Hold the Bolt/Spacer in place by hand. Flip the bracket over with the bolt pointing up. Hold the Assembly in place lining up the holes with the U-nuts. The 3/8"-16 x 1 1/2" Bolt installed in the previous step will thread into the U-nut that is in the frame rail. Thread it in while holding the mount in place. The bar mount area will fit into the OEM leaf spring area. The part of the Mount with the Bung welded to it will nest up into the floor pan of the car, similar to **Image 13**. Install a 3/8" Flat Washer on each of (2) 3/8"-16 x 1 1/4" Bolts and thread them into the remaining to OEM mounting locations with U-Nuts in them. **DO NOT TIGHTEN THE (3) BOLTS.** Repeat on the other side.



**REMOVE THE REAR SEAT BEFORE DOING THE NEXT STEPS. YOU WILL BE DRILLING THROUGH THE HUMP IN FRONT OF THE BOTTOM SEAT LATCH, PULL THE CARPET AND SOUND DEADENER UP TO EXPOSE THE AREA.**

**15.** Use a jack, or something similar, to push up on the inside of the Lower Mount. This will help nest the mount up into the floor pan. While pushing up on the inside of the mount, drill the top hole through the floor pan using a 3/8" drill bit. Also drill up through the center of the Bung. After you drill through the center of the bung, drill the hole to 5/8" from the top side. The hole through the flat plate will remain 3/8"



**16.** The kit includes (3) pairs of Backer Plates with (3) different hole configurations. The Top Plate only has a 3/8" & 5/8" hole. This is the Plate you will be installing at this time. Align the hole in the Top Plate with the hole you just drilled. Install a 3/8" Flat Washer on a 3/8"-16 x 1 1/4" Hex bolt and insert it through the hole in the Top Plate, Floor Pan, and Lower Mount. Install a 3/8" Flat Washer and 3/8"-16 Nylok Nut on the threads sticking through the Lower Mount. Tighten this bolt and the (3) already threaded into the U-Nuts.





### Front Lower Bar & Subframe Mount Installation

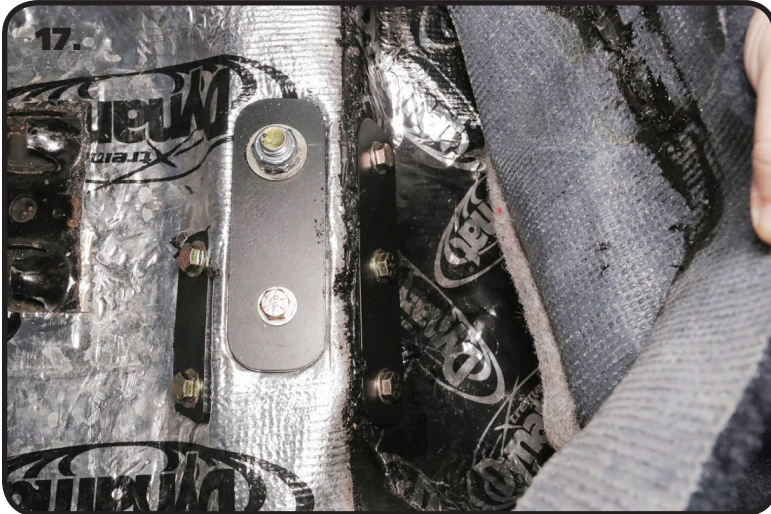

**17.** Drill the remaining 5 holes with a 3/8" drill bit. Install a 3/8" Flat Washer on each of (5) 3/8"-16 x 1 1/4" Hex Bolts. Line the 3 Hole Backer up with the front 3 drilled holes. Install a Bolt/Washer in each hole. Install a 3/8" Flat Washer & 3/8"-16 Nylok Nut on each bolt sticking through the Lower Bracket. Line the 2 Hole Backer up with the rear 2 drilled holes. Install a Bolt/Washer in each hole. Install a 3/8" Flat Washer & 3/8"-16 Nylok Nut on each bolt sticking through the Lower Bracket. Tighten all hardware to 45ftlbs. **NOTE: The 5/8" bolt will be installed later.**



**18.** Install the Aluminum Rear Frame Bushings in the rear shackle bushing holes. They are installed like the OEM shackle bushings, 1 into each side. The fit can vary due to the condition of the holes on your car. If the bushings are tight, you can pull them in by inserting the 5/8"-16 x 4 1/2" bolt through both of them, install a 5/18"-16 Nut and tightening the bolt/nut until the bushings are fully seated in the frame hole. Remove the bolt/nut after seating the bushings. Install the bushings in the driver and passenger side.



**19.** Attached the rear of the subframes to the newly installed Rear Frame Bushings. The kit includes a Driver and Passenger Subframe. Each one will be installed with the tabs to the inside of the car. Install a 5/8" Flat Washer on a 5/8"-11 x 4 1/2" bolt and insert it through the tabs and bushings with the threads to the inside of the car. With the bolt/washer installed, install a 5/8" Flat Washer and 5/8-11 Thin Nylok Nut on the threads sticking through. **DO NOT TIGHTEN.**





### Subframe Installation



**20.** The front of the Subframes will swing up and engage onto the Bung on the Front Lower Mount as seen in **Image 21**. Later cars have the brake line mounted on the drivers rear frame rail, this will need to be clearanced to allow the Subframe to swing up in place. **Image 20** shows this mount.



**21.** Swing the Subframe up in place and engage it with the Bung on the Lower Mount. Push the end of the Subframe up to seat it on the bung. Install a 5/8" Flat Washer on a 5/8"-11 x 4 1/2" **FULLY THREADED** Hex Bolt. Thread the Bolt/Washer in through the center hole of the Bung. Do this for both Subframes. Torque the front and rear 5/8" bolts to 100 ftlbs. After torquing the Hardware, install a 5/8" Flat Washer and 5/8"-11 Thin Nylok Nut on the Threads of the 5/8"-11 x 4 1/2" Bolt that is sticking up through the floor off the car. This is located by the top backing plate.

**THE SEAT BACK AND DIVIDER WILL NEED TO BE REMOVED FOR THE FOLLOWING STEPS.**



**22.** Center punch **ONLY** the lower hole of the forward tabs of the Subframes.



**23.** Drill the center punched hole with a 3/8" drill bit. **ONLY DRILL THE LOWER HOLE IN THE FORWARD TABS.**



### Upper Bar Bulkhead Installation



24. Use a die grinder, or similar tool, to slot the lower hole of the forward tabs. Use the Tab as a template for slotting the hole.



25. Set the Upper Bar Bulkhead in place over the driveshaft tunnel lining up the 2 lower holes with the 2 slots you just created.

**Note:** You will notice we used the bulkhead as a template to trim the rear seat divider. You can do this now or after the bulkhead is installed.



26. Install a 3/8" Flat Washer on each of (2) 3/8"-16 x 1 1/4" Hex Bolts. Insert a bolt/washer into the lined up lower holes. Install a 3/8" Flat Washer & 3/8"-16 Nylok Nut on bolts where they come through the forward tab of the subframe. Lightly tighten the bolts.





### Upper Bar Bulkhead Installation



**27.** Use the "V" in the top of the Upper Bar Bulkhead to measure center. Measure from each wheel well to determine the center of the bracket. You may need to tap the Bulkhead to one side or the other to get it close to centered. Snug the 2 bolts after getting it centered.

**Note:** The car in the image had OEM wheel tubs. IF YOU HAVE MINITUBS, YOUR MEASUREMENT WILL BE DIFFERENT FROM THE ONE IN IMAGE 27.

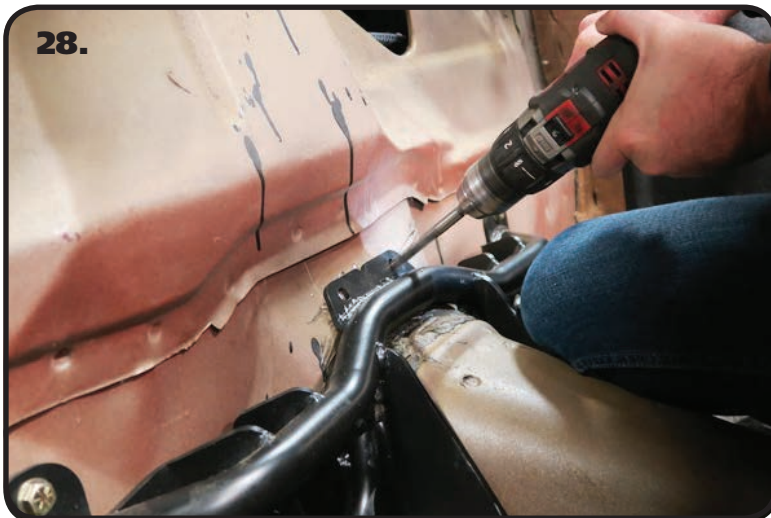

**28.** Drill the top 2 holes in the Bulkhead with a 3/8" Drill Bit. Install a 3/8" Flat washer on each of (2) 3/8"-16 x 1 1/4" Hex Bolts and insert them into the drilled holes.



**29.** Install the supplied Backer Plate on the bolts sticking through the floor pan. Install a 3/8" Flat Washer & 3/8"-16 Nylok Nut on each bolt. Torque to 45 ftlbs.



### Upper Bar Bulkhead Installation



**30.** The Bulkhead has a tab the goes forward on each side of the driveshaft tunnel, in the end of each tab is a 1/2" hole. Using the Bulkhead holes as a template, drill the driveshaft tunnel with a 1/2" drill bit. Do this for the forward hole in each tab. Insert the supplied 1/2"-13 x 1 1/4" bolt in each drilled hole with a 1/2" washer on the top side and bottom side, follow the bottom washer with a 1/2"-13 Nylok Nut. Torque the 2 bolts/nuts to 110 ftlbs.



**31.** Drill the top 2 outer holes in the Bulkhead with a 3/8" Drill Bit. Install a 3/8" Flat washer on each of (2) 3/8"-16 x 1 1/4" Hex Bolts and insert them into the drilled holes.



**32.** Removed the lower nut and washers from the Forward Subframe Tabs.





### Using the Template

33.



**33.** Cut the 4 Outer Slots out of the template. Slide it over the 4 bolts sticking through the Forward tabs. Make sure the ARROW POINTS UP!

34.

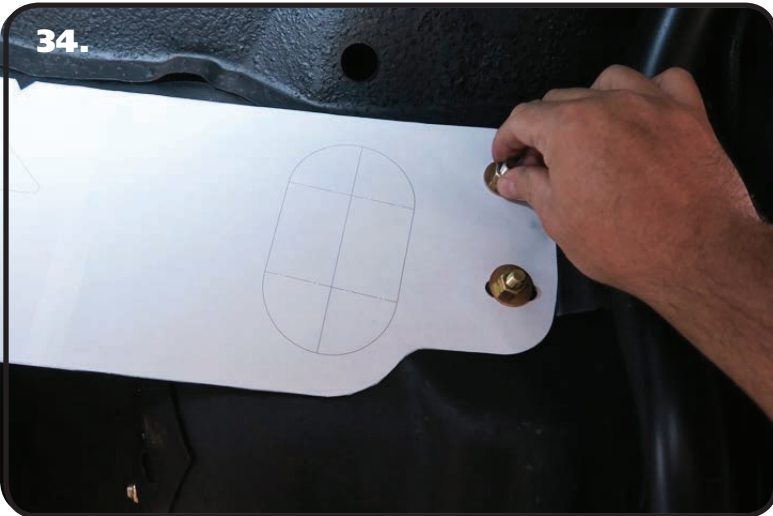

**34.** Install a 3/8" Flat Washer and 3/8"-16 Nylok Nut on the bolts sticking through the Forward Tabs and Template. Tighten the nuts finger tight to help hold the template in place.

35.

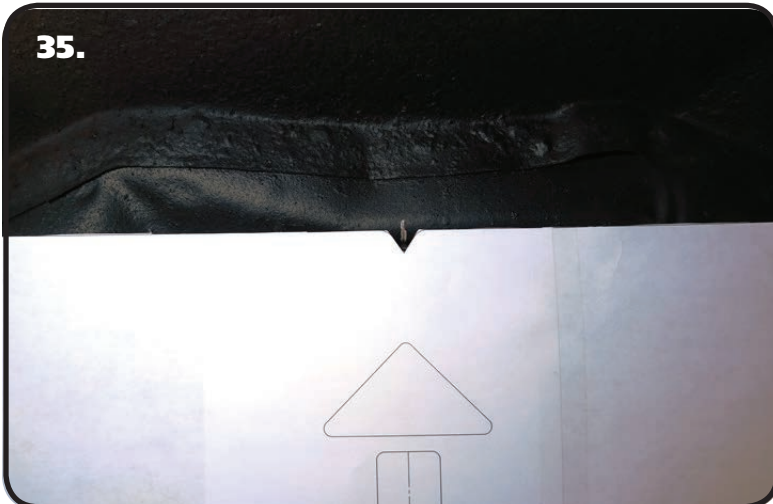

**35.** Use the Notch in the top of the Template to center it. Measure out from the frame rail on each side to find center. We found it easier to put a mark on the car, then align the template notch with the mark.



### Upper Bar Hole Cutting

36.

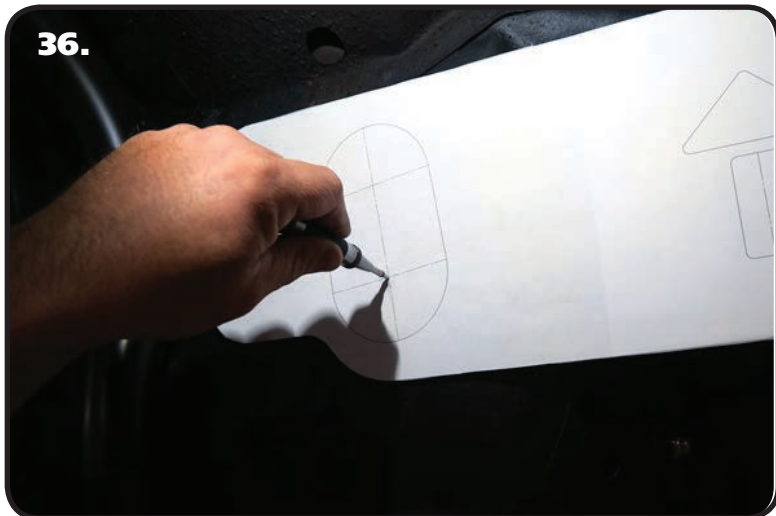

36. Use the " + " marks in the template to center punch the car body. Center punch all (4) " + " marks.

37.



37. Drill the center punched spots with a 3" hole saw.

38.

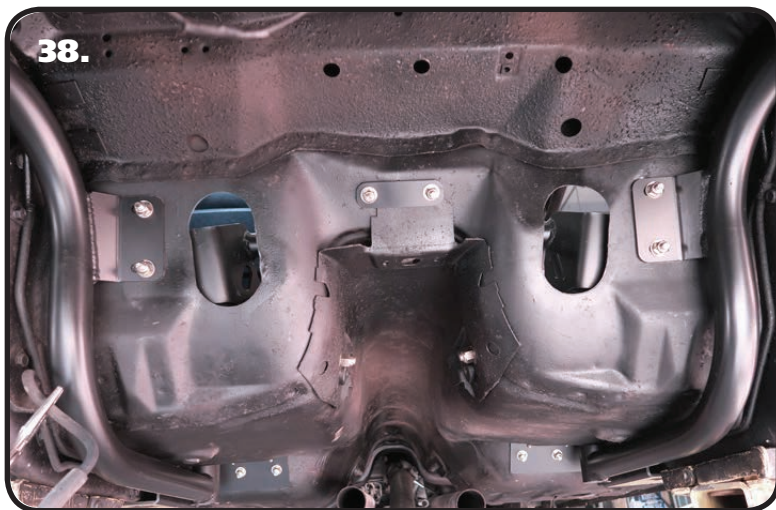

38. Use a straight edge to draw a reference line from circle to circle. You will be cutting out the rest to make an obround. **Image 38** shows both sides cut out. After connecting the holes, remove any burrs from the edge of the holes. Install a 3/8" Flat Washer & 3/8" -16 Nylok Nut on each of the 4 bolts sticking through the Forward Tabs that were installed previously. **DO NOT TIGHTEN THESE 4 BOLTS AT THIS TIME, THEY WILL GET TIGHTENED AFTER THE SHOCK CROSSMEMBER IS INSTALLED.**



### Upper Bar Hole & Installing Lower 4 Link Bars



**39.** Depending on the year of your car, you may need to smooth out the outer edge of the upper 4 link bar hole to make the surface even. You can do this by inserting a solid object on the inside and hammering it smooth.



**40.** The 4 Link Bars in this kit are equipped with R-Joints. The R-Joints require spacers to be installed in them. Insert a Spacer into each side of the R-Joints. The Spacers are installed into the R-Joint with the small diameter going into the center pivot ball. Push them in until they stop.



**41.** The Long 4 Link Bars are the lower bars. They are attached to the Lower Mount with a 5/8"-16 x 2 3/4" & 5/8"-18 Thin Nylok Nut. With the R-Joint spacers already installed, insert one end of the Lower Bar into the Lower Mount. Line up the R-Joint with the holes in the Lower Mount and insert the bolt through the holes. The Bolt can only be installed from the outside. Insert the Nut through the access hole in the lower mount. You may have to pull the bolt out some to get the nut inserted. Repeat on both sides and tighten the Bolts/ Nuts enough to eliminate any gaps.





### Installing Lower Axle Mounts

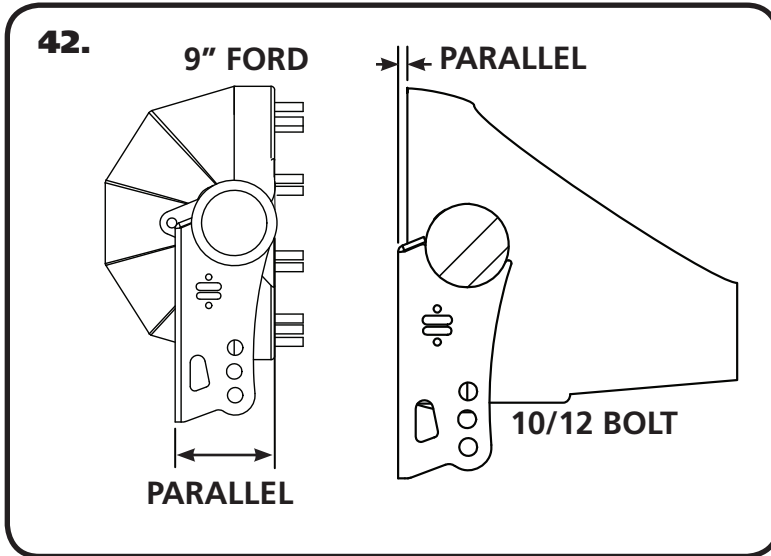

**42.** The Lower Axle Mounts need to be welded to the rear differential before placing it in the car. The Lower Axle Mounts need to be parallel to the flat surface of the center section. On a 10/12 bolt, it is the surface the rear cover bolts to. On a 9", it's the surface the center section bolts to. The axle mounts need to be installed at 40" center to center and centered on the differential. **Image 42** shows a side view of a 10/12 bolt and 9" illustrating the surface we used as a reference to place the Lower Mount. It is best done on a flat surface. We start by placing the differential on jack stands. We use a digital angle finder to get the vertical surface, shown in **Image 42**, straight up and down.

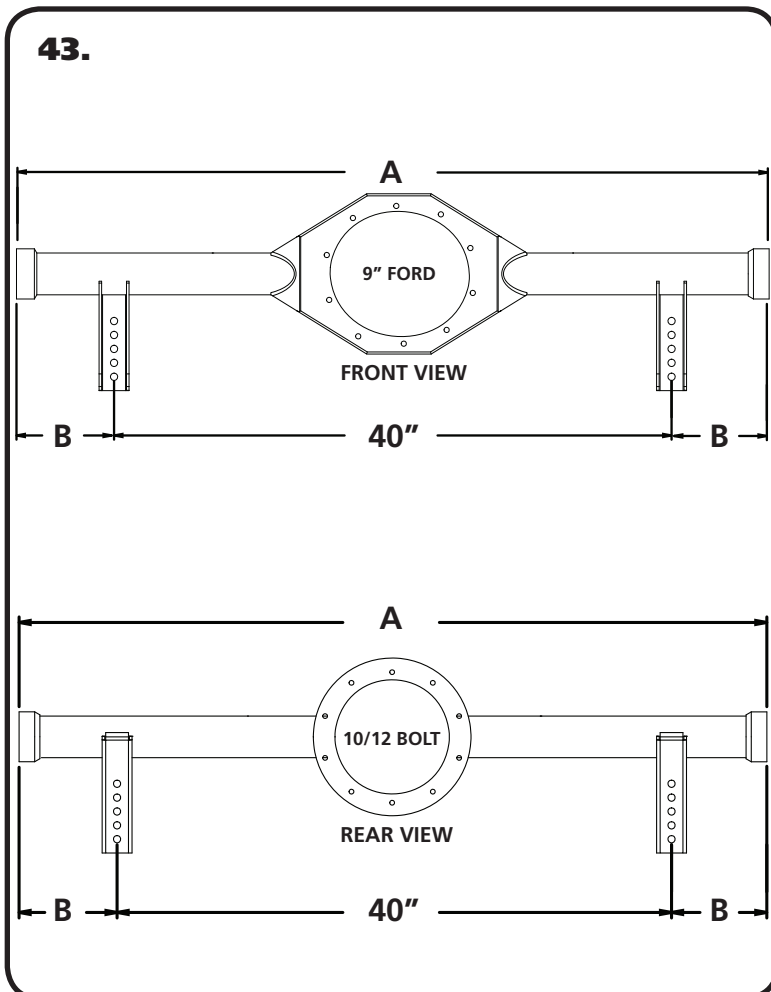

**43.** The Lower Axle Mounts need to be 40" center to center and centered on the differential. Start by establishing a common measurement point on each side of the axle to get a width measurement, Measurement "A". You will need this to get the "B" Measurement to use as a reference when positioning the lower mounts. Once the width measurement "A" is established, subtract 40 from that measurement. Take the remainder of A - 40 and divide by 2. The remainder will be your "B" measurement that will be used on both sides. Using the "B" measurement, measure from the location that was used to establish your width and put a mark on the axle tube. Do this for both sides. To check your self, measure from mark to mark to see if it is 40". The CENTER of the lower mounts will be placed at the mark on each side of the differential with the rear surface parallel with vertical surface shown in **Image 42**.

**Formula:**

$$A - 40 = X$$

$$X/2 = B$$

**44.** Place the mounts using Steps 42 & 43. Tack weld the brackets in place and verify their location. Lay 1" welds on the inside and outside of the lower mounts. Skip around from one side to the other to avoid overheating the tube.



### Attaching 4 Link Bars to Differential



45.

**AFTER THE LOWER MOUNTS HAVE COOLED, REPOSITION THE REAR DIFFERENTIAL UNDER THE CAR.**

45. Verify that the Spacers are installed in the lower bars rear R-Joints. The Spacers are installed into the R-Joint with the small diameter going into the center pivot ball. Push them in until they stop.



46.

46. Insert the Lower Bar R-Joint into the Lower Axle Bracket. Line the through hole of the R-Joint with the MIDDLE set of holes of the Axle Bracket. Install a 5/8" Flat Washer on to a 5/8"-16 x 3" Hex Bolt, insert into the lined up holes. Install a 5/8" Flat Washer followed by a 5/8"-18 Thin Jam Nylok Nut. Repeat on both sides and tighten the Bolts/Nuts enough to eliminate any gaps..



47.

47. One helpful trick to help maintain ride height and pinion angle while positioning the differential is to put a spacer between the axle and the outside of the frame as shown in **Image 47**. This spacer should be 5 1/4" tall giving the Shockwave an eye-to-eye measurement of approximately 14 1/2". When measuring the axle center you can measure off of the frame rails. We also use a plum bob off the quarter panels to double check the axle center. Refer to Page 20 on Setting the Pinion Angle.



### Setting Pinion Angle

**READ PAGES 20-23 ON SETTING PINION ANGLES, UPPER BAR TAB JIG INSTALLATION, & SETTING RIDE HEIGHT.**

How do you set the pinion angle? On a single-piece shaft you want to set it up where a line drawn through the center of the engine crankshaft or output shaft of the transmission and a line drawn through the center of the pinion are parallel to each other but not the same line.

Your transmission angle should be around 3 degrees down in the rear. If it is more or less than 3 degrees, you might want to consider changing it. Too little angle on the transmission reduces the amount of oil getting to the rear bushing. Too much transmission angle will increase the working angles of the u-joints which will increase the wear. With the transmission at 3 degrees down in the rear, you will want to set the pinion 3 degrees up in the front.

A simple way to do this is to place a digital angle finder or dial level on the front face of the lower engine pulley or harmonic balancer. This will give you a reading that is 90 degrees to the crank or output shaft unless you have real problems with your balancer. At the other end, you can place the same level or angle finder against the front face of the pinion yoke that is also at 90 degrees to the centerline. If you rotate the yoke up or down so both angles match, you have perfect alignment.

Road testing will tell you if you have it right. If you accelerate and you get or increase a vibration, then the pinion yoke is too HIGH. Rotate it downward in small increments of a degree or two until the problem goes away. If you get or increase a vibration when decelerating, then the pinion yoke is too LOW. Rotate it upward to correct it.

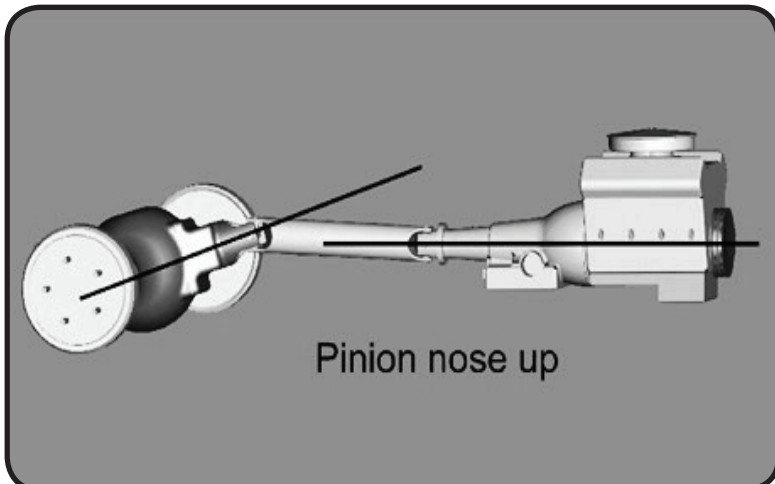
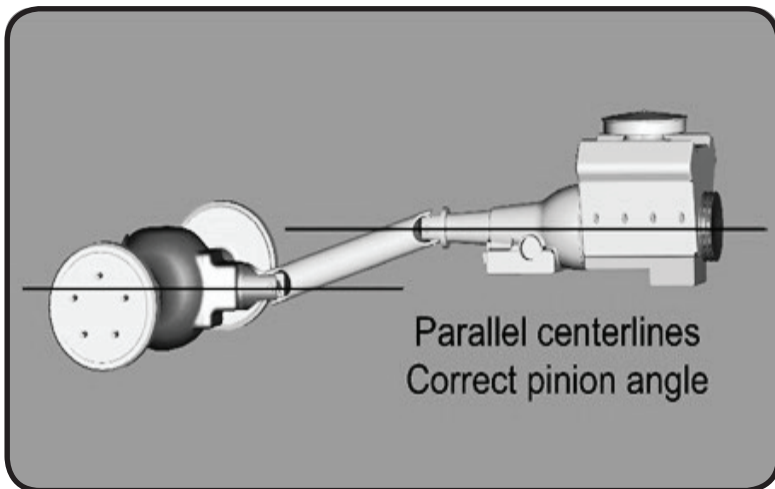
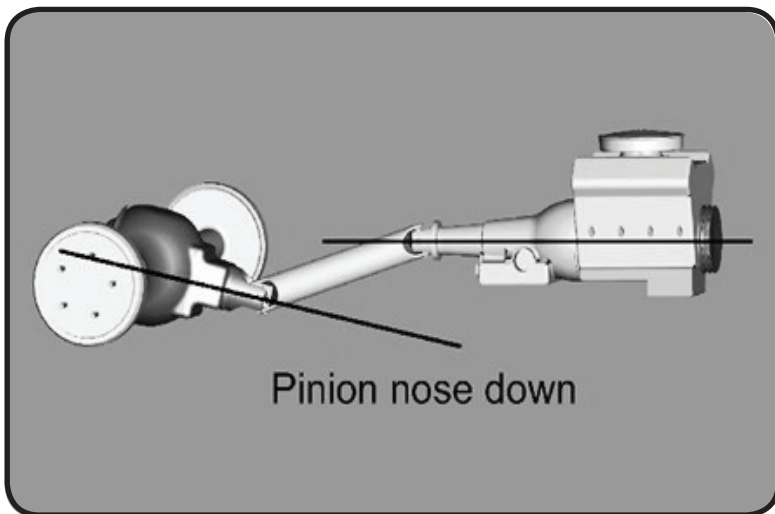





### Upper 4 Link Bar Installation

**48.** The Upper Bar Bulkhead is designed with adjustable Anti Squat. Anti Squat reduces the amount the rear suspension squats on acceleration. Anti Squat is measured in a percentage, the higher the percentage of anti squat the less the rear of the car squats. Reducing the rear squat keeps the rear suspension from compressing as much therefor reducing the amount the front suspension extends. This will help keep the suspension geometry in it's optimized range. Anti squat uses the mechanics of the rear suspension to reduce squat rather than the shocks and springs. It uses the same mechanics to help put weight to the rear tires during acceleration. Several factors effect the amount of anti squat a car needs; horsepower, tires, vehicle weight, and track surface are some of the main ones. You can use the different settings in this suspension to help dial in your car's handling. Keep in mind, the higher the rear squat percentage the less effective the rear tires will be under hard braking for corner entry. We control the Anti squat percentage by raising and lowering the front of the upper control arm. The centered position is approximately 60% Anti Squat. We have found this to be a good starting point.

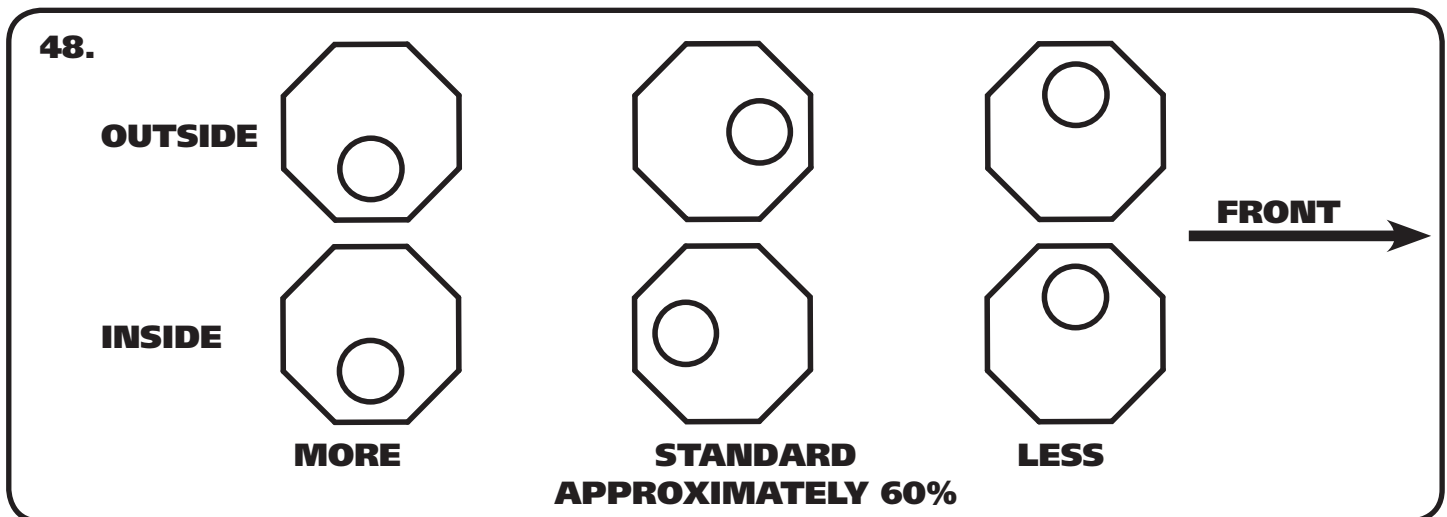

The Adjustment Washers supplied in the kit are octagon shaped with an offset hole. Due to the design of the Bulkhead and clearances, the standard centered position requires the Adjustment Washers to be ran offset of each other. This will make sense when you go to install them. **Illustration 48** shows how the Adjustment Washers should be positioned with the Bolt running through the Washers, Bulkhead, and R-Joint. The Bulkhead has an Arced Slot for the bolt to run up and down in. This Arc helps keep the Pinion Angle when you adjust the Anti Squat. The Upper Bar Bulkhead has tabs above and below the Washers to keep them in position. Tightening the Bolt/Nut locks them in place.



### Installing Axle Tabs

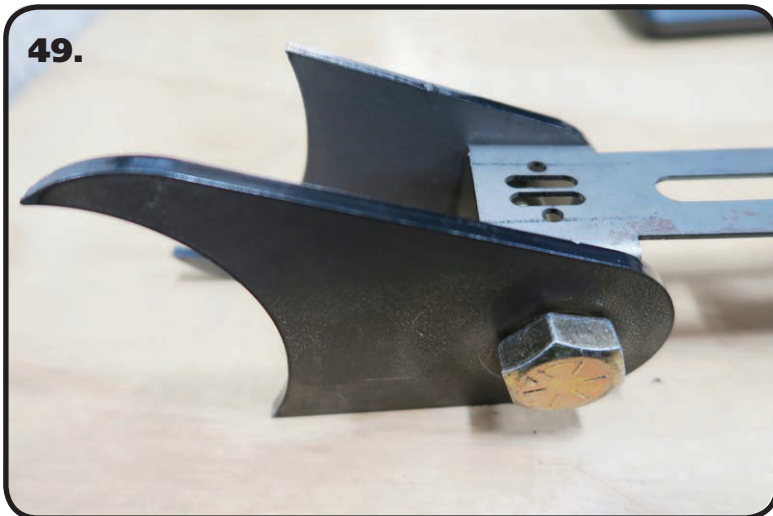

**49.** To simplify the upper tab installation, tack weld the assemblies together. The Upper Tab Assemblies are a mirror image of each other, **Image 49** shows the Driver Assembly. The (4) Tabs are identical. Start by putting a Tab on each side of the Setting Jig, 1 long side down, 1 long side up. Set the Tabs on a flat surface, the outer edges will be parallel with each other.



**50.** Set the Backer on the Tabs with the curved side toward the bolt. The flat side of the Backer needs to be positioned 1/4"-3/8" up from the bottom on the short side of the tabs. Center the Backer side to side and tack weld it in place. **Repeat this on the other set of tabs making a mirror image of the first.** Get both sets tacked together.



**51.** Use **Illustration 48** on Page 21 as a reference for installing the Indexing Washers. Install the Washers with the Setting Jig in the MIDDLE POSITION. The Outer Washer is installed with the hole forward. The Inner Washer is installed with the hole to the rear. The Setting Jig is attached to the Bulkhead using a 5/8"-18 x 3 1/2" Hex Bolt & 5/8"-18 Thin Nylok Nut with a 5/8" Flat Washer on each side.



### Upper Bar Tab Installation Jig

#### Upper Bar Installation Jig

- This jig has been supplied to aid in the installation of the upper 4 link bar. It can be temporarily used to properly align, locate and weld the tabs onto the axle. It will also ensure that the mounting bolts are parallel to the ground.
- Follow the diagram below to set the jig to the same length as the upper bar, use the 3/8" x 3/4" bolt and nuts to set the length.
- Position the axle at ride height. Center the axle left to right between the quarter panels. Set pinion angle.
- Bolt one end of the jig to the cradle using a 5/8" x 3 1/2" bolt.
- Using another 5/8" x 3" bolt, fasten the axle tab assemblies to the other end. There should be a driver and passenger assembly.
- Swing the bar down letting the tabs rest onto the axle. Trim the brackets as necessary to minimize the gap to be welded.
- Check pinion angle, ride height and axle center. Tack-weld the tab assemblies in place on the axle.
- Remove jig and install upper bar.
- Repeat this process for the other side.
- Recheck pinion angle, ride height and axle center. (Sound familiar?)
- After the tabs have been tack welded on both sides, remove the setting jig. Let the axle drop down for better access to the tabs. Lay 1" welds on the inside and outside of the tabs. Skip around from one side to the other to avoid overheating the tube.

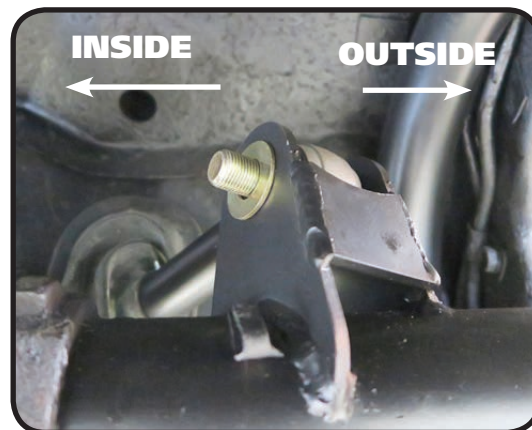
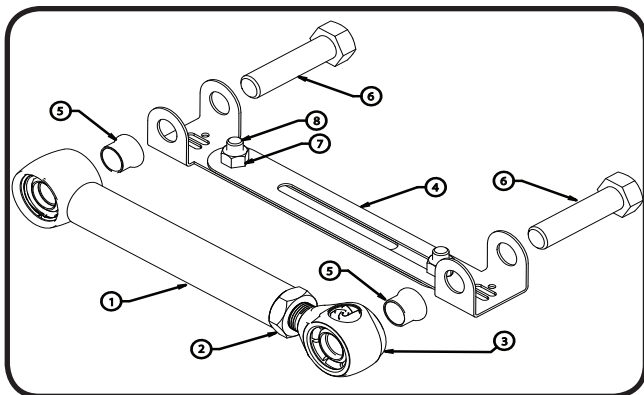

Item#	Description
1	Upper Bar
2	3/4" -16 Jam Nut
3	Heim End
4	Alignment Jig
5	Aluminum Spacer
6	5/8" x 2 3/4" Bolt
7	3/8" -16 Nut
8	3/8" -16 x 3/4" Bolt







### Installing Upper 4 Link Bars



**52.** Verify the Spacers are installed in the R-Joints of the Upper Bars. Insert the Upper Bar through the hole cut previously. The R-Joint will insert into the Bulkhead aligning the though hole with the slots in the Bulkhead.



**53.** Use **Illustration 50** on Page 23 as a reference for installing the Indexing Washers. Install the Washers with the upper bar in the MIDDLE POSITION. The Outer Washer is installed with the hole forward. The Inner Washer is installed with the hole to the rear. The R-Joint is attached to the Bulkhead using a 5/8"-18 x 3 1/2" Hex Bolt & 5/8"-18 Thin Nylok Nut with a 5/8" Flat Washer on each side. . Repeat on the other Bar. Torque the hardware to 75 ftlbs.



**54.** Slip the Rubber Boots over the Upper 4 Link Bars. Insert them into the cut holes. They install like a rubber grommet, they have a groove around the outside edge to nest the sheet metal into.



### Installing Upper Bars & Shock Crossmember

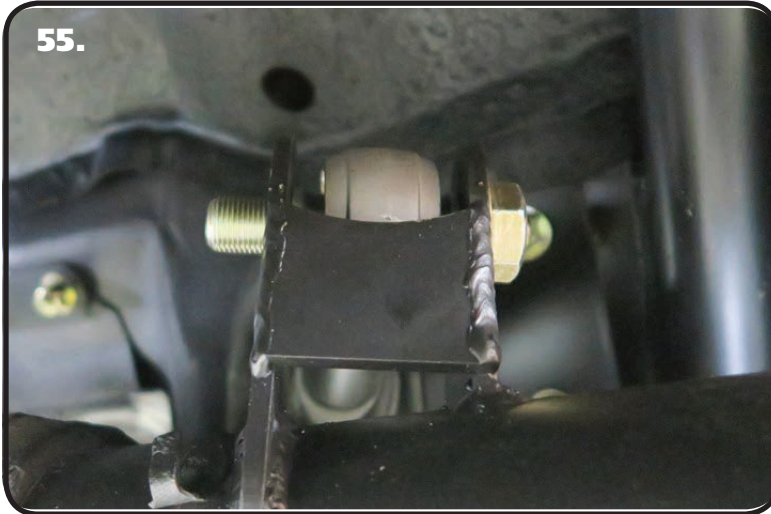

55.

55. Verify the Spacers are installed in the R-Joints of the Upper Bars. Insert the R-Joint into the upper bar mount of the rear differential. Install a 5/8" Flat Washer on to a 5/8"-16 x 3" Hex Bolt. Line up the holes in the axle tabs with the through hole of the R-Joint, insert the bolt/washer from the OUTSIDE with the threads pointing inward. Install a 5/8" Flat Washer followed by a 5/8"-18 Thin Jam Nylok Nut. Repeat on both sides and tighten the Bolts/Nuts enough to eliminate any gaps.



56.

56. Insert the Shock Crossmember into the tabs on the Subframe. It is installed with the Swaybar Mounts to the REAR of the car. There are (2) mounting holes on each side that line up with the slots in the Subframe Mounts.



57.

57. Install a 3/8" Flat Washer on each of (4) 3/8"-16 x 2 1/4" Hex Bolts. Install a Bolt/Washer in each of the (4) mounting holes. With the Bolts installed, install a 3/8" Flat Washer and 3/8"-16 Nylok Nut on each of them. Torque to 45 ftlbs. **ALSO TORQUE THE 4 BOLTS TO 45 FTLBS THAT WERE LEFT LOSE IN STEP 38.**

**IF YOUR ALSO INSTALLING THE REAR MUSCLEBAR, INSTALL IT BEFORE INSTALLING THE SHOCKWAVES/ COILOVERS.**





### Installing Lower Shock Mount & CoilOvers/ShockWaves



**58.** The Lower Shock Mount attaches with (1) 1/2"-13 x 1 1/4" Hex Bolt, (1) 1/3"-13 x 1 3/4" Hex Bolt, & (2) 1/2" Flat Washer, & (2) 1/2"-13 Nylok Nuts. The Lower Mount gets attached to the 2nd and 3rd hole up from the bottom of the Axle Mount. When the Shock Mount is installed correctly, the bottom of the Lower Shock Mount is 1/8" above the bottom of the Axle Mount. Insert the Bolts through the Aluminum Shock Mount with the 1 1/4" long bolt in the top bolt, 1 3/4" in the bottom hole. Insert the bolts through the Axle Mount and install the Flat Washers & Nylok Nuts on the Threads sticking through. Repeat on both sides and torque the Bolts/Nuts to 75 ftlbs.

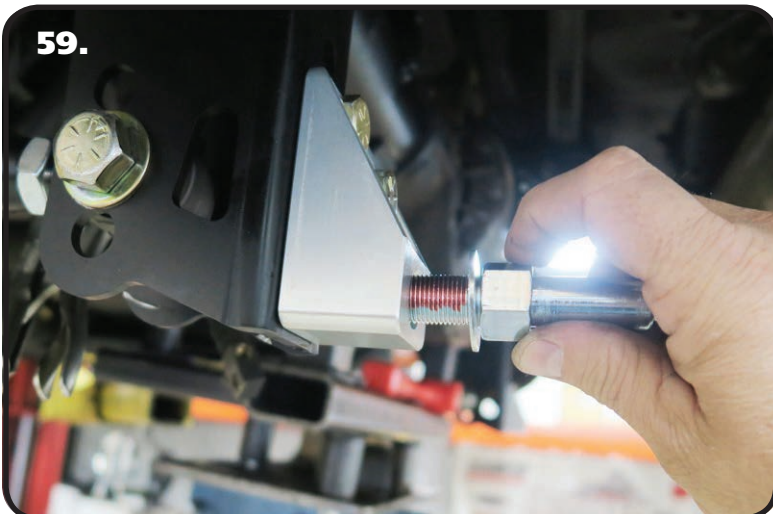

**59.** Installing the Shock Stud into the Lower Mount. Install a 5/8" Flat Washer onto the 5/8"-18 threads of the shock stud. Apply Red Loctite to the 5/8" threads of the stud. Thread the Shock Stud into the threaded hole of the Lower Mount. Repeat on both sides and torque the Shock Stud to 65-75 ftlbs.



**60.** Ridetech CoilOvers or ShockWaves require a spacer on each side of the bearing. The Upper Crossmember uses a 5/8" ID spacer that is 3/8" long (90002042). The overall width with a spacer on each side will be 1 1/4". **The small side of the spacer goes towards shock bearing.**





### Installing CoilOvers/ShockWaves



**61.** Insert the Shock with the 5/8" ID Spacers into the Shock Crossmember. Line up the holes in the crossmember with the spacers and shock bearing. Install a 5/8" Flat Washer on to a 5/8"-16 x 2 1/2" Hex Bolt, insert into the lined up holes. Install a 5/8" Flat Washer followed by a 5/8"-18 Thin Jam Nylok Nut. Torque to 75 ftlbs.



**62.** The Shock Stud requires spacers that are .400" long (90002067). Install a 5/8" ID 90002067 spacer (**Small side towards shock body**) onto the lower Shock Stud. Slide the bottom of the Shock onto the Stud. Install a second 5/8" ID 90002067 Spacer onto the Stud (**small side towards shock**). You may need to jack the rearend up to Slide the Shock onto the Stud.



**63.** Install the 7/16" Flat washer and 7/16" Nylok nut. Tighten the upper and lower shock bolts. Torque the Upper Bolt to 75 ftlbs and the Lower Nut to 40 ftlbs. The designed ride height of the CoilOver/Shockwave is 14 1/2" center to center.



### Rear Seat Modifications



**64.** The rear seat frame will need to be modified to clear the bulkhead. A new Frame Wire is included to help stiffen the seat. Safety Wire is included to wire the Frame Wire to the existing seat frame. **Image 64** has circles around the area that will need to be safety wired. You will also notice that part of the OEM seat frame has been cut out, we will show you where to cut it.

**Note:** The Frame Wire and safety wire is all Stainless, it does not need to be coated.

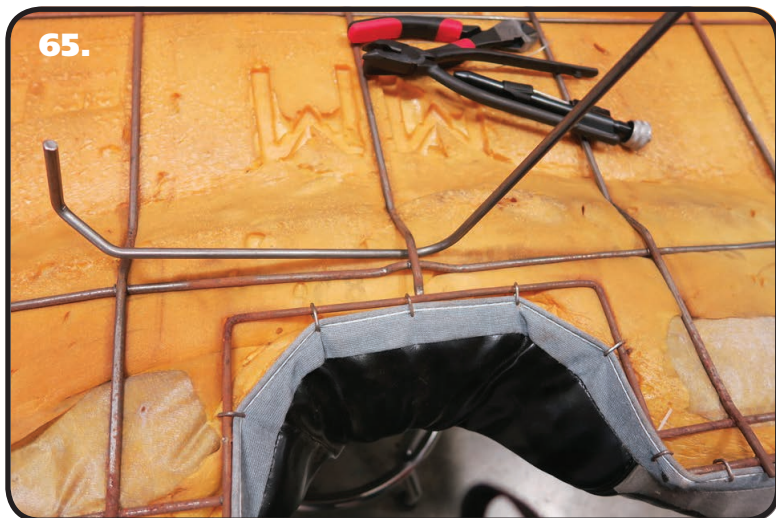

**65.** The Frame Wire needs to be inserted under the middle wire, right about the first LONG horizontal frame wire. It will lay on top or beside of other frame wires.



**66.** The kit includes (6) long pieces of Safety Wire. Cut the long pieces in about 3" pieces. We will start in the location close to the attaching loop. Start by wrapping a 3" piece of Safety Wire around the Frame Wire and seat frame close to the 1st bend of the frame wire. Twist it a little to hold it in place.





### Rear Seat Modifications



**67.** We used Safety Wire Pliers to twist the wires, but you can use regular Pliers or Vise-Grips to twist it. Grab the wire approximately 1" from the frame wire and twist it until it is tight. If you twist it too much, it will break. After twisting the safety wire, trim off some of the twisted part leaving approximately 1/2". Safety Wire the Frame Wire to the seat frame at every location circled in **Image 64**.

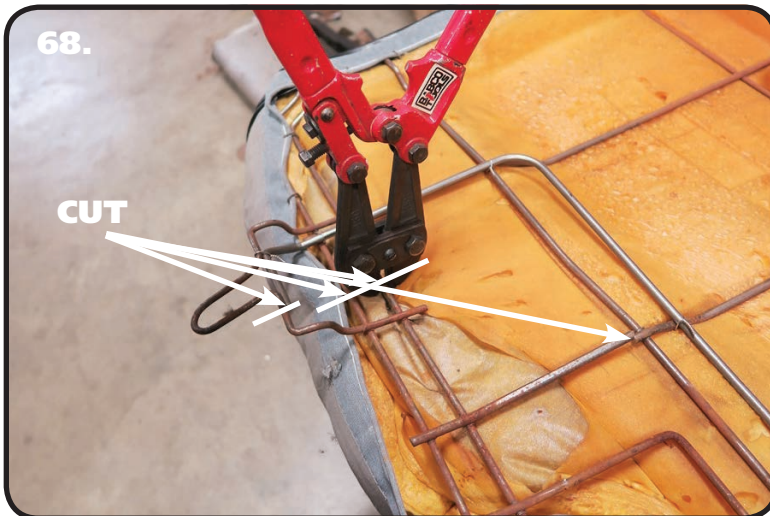

**68.** Images 68 & 69 illustrate where to cut the OEM seat frame. The BOTTOM 3 horizontal wires get cut in-line with the end of the Frame Wire. The 3 CENTER vertical wires get cut below the 1st horizontal wire that runs the width of the seat. We used a bolt cutter to cut them, but they can be cut with a saw. You will need to disconnect any hog rings that attach the seat cover to the area being removed.



**69.** Image 69 has the locations that need to be cut circles. It also shows the seat with the section removed.





### Rear Seat Modifications



70.

**70.** The kit includes Hog Rings and Extensions to attach the seat cover to the frame. The center can be pulled up to the wire above it and attached with Hog Rings.



71.

**71.** The Kit includes 2" Extension Rings to help with the longer span. It is necessary to Hog Ring 2 of the together to reach the wire with the seat cover. The idea is to keep the seat cover from coming loose.

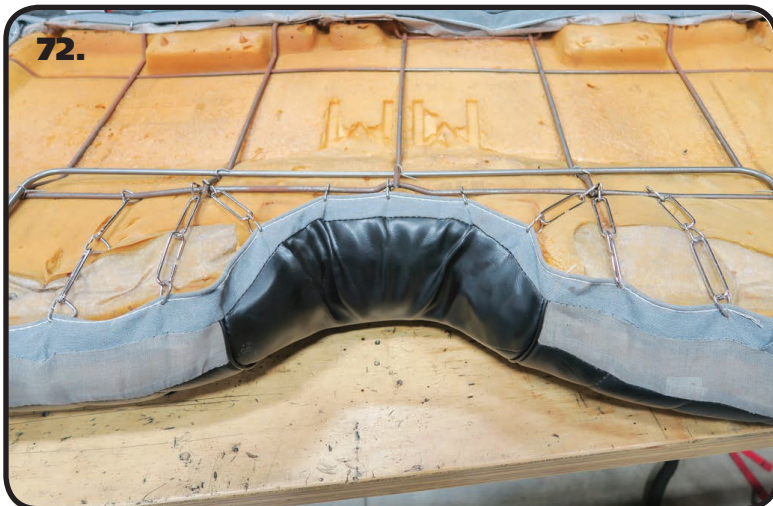

72.

**72.** Image 72 illustrates how we did our seat. We hog ringed (2) 2" Extensions together to reach the seat frame on the outer.

**73.** Reinstall the rear divider and seat. You will need to trim the rear divider to clear the bulkhead.



**Part # 21150701 - 5.2" Stroke HQ Series Shockwave**

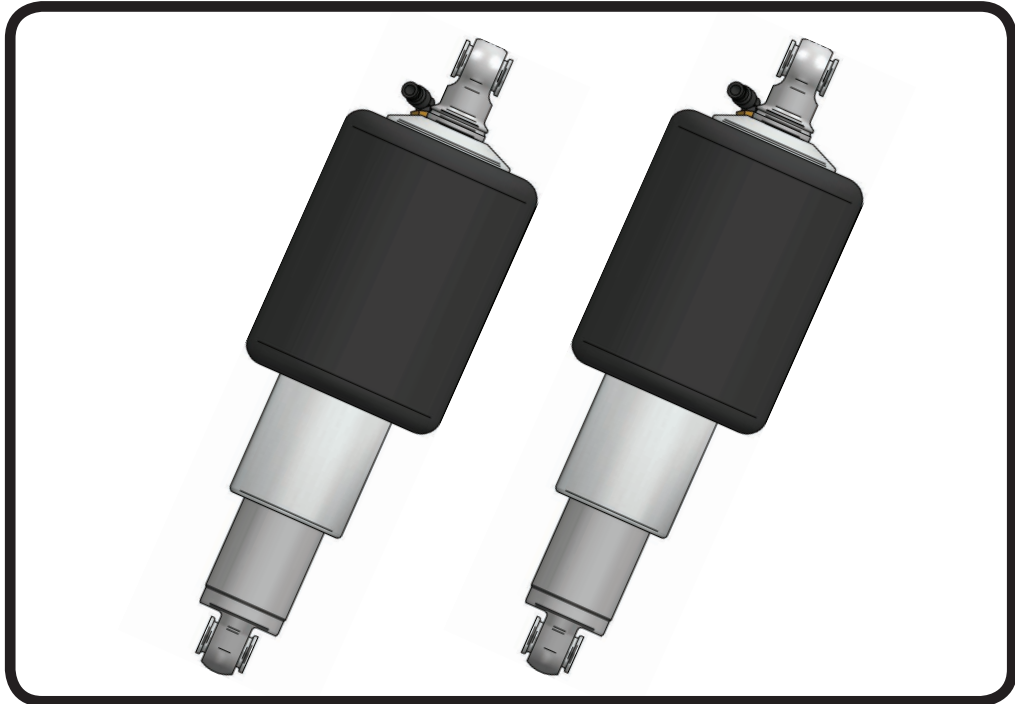

**Recommended Tools**

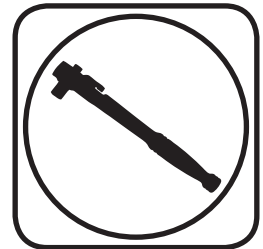

# 7000 Series Bellow, Eye/Eye 5.2" Shock Installation Instructions

Table of contents

Page 50..... Included components

Page 51..... Notes and Care of Your Shockwave

Page 52..... Shock Adjustment

ShockWave Dimensions:

Center of bearing to Center of bearing:	
Compressed:	11.85"
Ride Height:	14.60"
Extended:	16.42"

[www.ridetech.com](http://www.ridetech.com)   
812-482-2932



### Major Components .....In the box

Item #	Part #	Description	QTY
1	24159999	5.2" Stroke HQ Series Shock	2
2	90002024	Shock Eyelet	2
3	24090799	7000 Series, 4" Diameter AirSpring	2
4	70008193	AirSpring Locking Ring (Installed on Shock)	2
5		Spacers - included in 4 Link Kit	
	90001994	5/8" ID Bearing (installed in shock and eyelet)	4
	90001995	Bearing Snap Ring (installed in shock and eyelet)	8

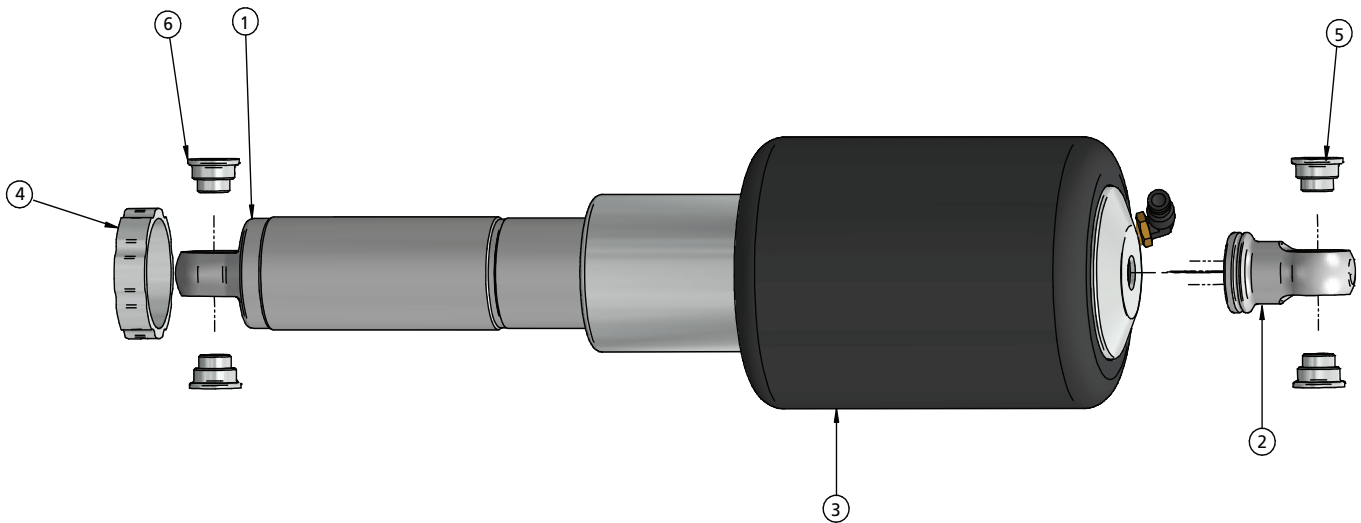

**WARNING: ATTEMPTING TO REMOVE THE AIR FITTING WILL DAMAGE IT AND VOID THE WARRANTY.**





### Notes and Care of your Shockwaves

#### NOTES:

**WARNING: ATTEMPTING TO REMOVE THE AIR FITTING WILL DAMAGE IT AND VOID THE WARRANTY.**

You can clock the airfitting location on the ShockWave by turning the AirSpring assembly of the shock. Make sure the fitting doesn't contact the frame.

When cutting the airline, use a razor blade. The cut needs to be a clean cut and square for the airline to seal properly.

The Locking ring on the shock is **NOT** adjustable. These rings are set at the factory to optimize the AirSpring stroke with the shock stroke.

### The care and feeding of your new ShockWaves

1. Although the ShockWave has an internal bumpstop, **DO NOT DRIVE THE VEHICLE DEFLATED RESTING ON THIS BUMPSTOP. DAMAGE WILL RESULT.** The internal bumpstop will be damaged, the shock bushings will be damaged, and the vehicle shock mounting points may be damaged to the point of failure. This is a non warrantable situation.
2. Do not drive the vehicle overinflated or "topped out". Over a period of time the shock valving will be damaged, possibly to the point of failure. This is a non warrantable situation! If you need to raise your vehicle higher than the ShockWave allows, you will need a longer unit.
3. The ShockWave is designed to give a great ride quality and to raise and lower the vehicle. **IT IS NOT MADE TO HOP OR JUMP!** If you want to hop or jump, hydraulics are a better choice. This abuse will result in bent piston rods, broken shock mounts, and destroyed bushings. This is a non warrantable situation.
4. Do not let the ShockWave bellows rub on anything. Failure will result. This is a non warrantable situation.
5. The ShockWave product has been field tested on numerous vehicles as well as subjected to many different stress tests to ensure that there are no leakage or durability problems. Failures have been nearly nonexistent unless abused as described above. If the Shockwave units are installed properly and are not abused, they will last many, many years. ShockWave units that are returned with broken mounts, bent piston rods, destroyed bumpstops or bushings, or abrasions on the bellows will not be warrantied.



### Shock Adjustment

#### Shock adjustment 101- Single Adjustable

##### Rebound Adjustment:

How to adjust your new shocks.

The rebound adjustment knob is located on the top of the shock absorber protruding from the eyelet.

You must first begin at the ZERO setting, then set the shock to a soft setting of 20.



-Begin with the shocks adjusted to the ZERO rebound position (full stiff). Do this by rotating the rebound adjuster knob clockwise until it stops.



-Now turn the rebound adjuster knob counter clock wise 20 clicks. This sets the shock at 20. (settings 21-24 are typically too soft for street use).

##### Take the vehicle for a test drive.



-if you are satisfied with the ride quality, do not do anything, you are set!

-if the ride quality is too soft increase the damping effect by rotating the rebound knob clock wise 3 clicks. **CONTINUE ON NEXT PAGE.**

##### Take the vehicle for another test drive.



-if the vehicle is too soft increase the damping effect by rotating the rebound knob clock wise 3 additional clicks.



-If the vehicle is too stiff rotate the rebound adjustment knob counter clock wise 2 clicks and you are set!

Take the vehicle for another test drive and repeat the above steps until the ride quality is satisfactory.

##### Note:

**One end of the vehicle will likely reach the desired setting before the other end. If this happens stop adjusting the satisfied end and keep adjusting the unsatisfied end until the overall ride quality is satisfactory.**

### STILL HAVE QUESTIONS?

#### Tech line hours

Monday - Friday

8AM - 6PM (EST) ..... 812-482-2932