



Part # 11340298⁽⁶³⁻⁷⁰⁾/**113520298**⁽⁷¹⁻⁷²⁾ - C10 Air Suspension System

Front Components:

11343699/11353699	Front Upper StrongArm
11341499/11351499	Front Lower StrongArm
11349300/11359300	Front Spindles and Caliper Brackets
11330910	Front CoolRide & Shock Kit
11369100	Front MuscleBar

Rear Components:

11337199	Rear StrongArm System
21150801	Rear Shockwaves

Recommended Tools

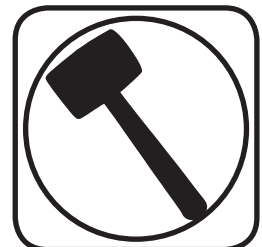

**C-10 Air Suspension
Installation Instructions**

Table of contents

Pages 2-4..... Front Lower StrongArms
 Pages 5-7..... Front Upper StrongArms
 Pages 8-11.....Front CoolRide & Shock Kit
 Pages 12..... Spindles
 Pages 13-22.....Rear StrongArm System
 Pages 22-24.....Rear Shockwaves
 Pages 25-26.....Shockwave Care and Adjustment
 Pages 27-30.....Front MuscleBar





350 S. St. Charles St. Jasper, In. 47546

Ph. 812.482.2932 Fax 812.634.6632

www.ridetech.com

Part # 11341499(63-70)/11351499(71-72)
63-70 C-10 Front Lower StrongArms
For Use w/ CoolRide

Components:

1	90000502	Driver side lower arm
1	90000503	Passenger side lower arm
1	90000912/90000909	63-70/71-72 Lower ball joint
2	90000521	Cross shaft
2	90000471	Shock T Spacer
4	90000915	Lower control arm bushings
4	99753001	Washer, 3/4" (B) x 2 1/2" (D) x 1/8" (T), Zinc Plated
4	99752005	3/4"-16 jam nut

STRONG ARMS™

by Air Ride Technologies

Installation Instructions

Note: These control arms were designed for use w/ the RideTech bolt-on shock kit & MuscleBar swaybar. The factory shocks and sway bar will not work.

Note: These Strong Arms are used on trucks of model years 1963-1987. Throughout these years 3 different ball joints used; some are very similar. Be sure to use the correct ball joint for the year spindle you are using.



1. Bolt the lower Strong Arm to the frame using the OEM fasteners. The supplied cross shaft has 2 sets of holes. This CoolRide control arm uses the set of holes that are 8.705" center to center. **Image 2** illustrates the holes used. Make sure to align the dowel in the frame with one of the holes in the cross shaft that is 8.705" apart.

2. Slide the boot over the ball joint then fasten the lower ball joint to the spindle using the new castle nut and cotter pin supplied.

3. Fasten the air spring to the lower control arm using a 3/8" x 3/4" bolt supplied w/ the CoolRide kit.

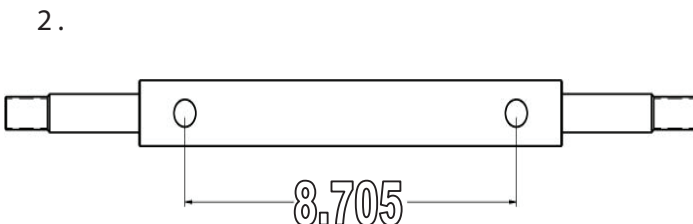

4. Thread the grease zerk into the ball joint and grease.

5. With the suspension at **mid travel**, the cross shaft nuts can be tightened.

6. The truck must be realigned after installation.

STRONG ARMS™

by Air Ride Technologies

Item #	Description	Qty.
1.	Driver side arm	1
2.	Cross shaft	1
3.	Ball joint	1
4.	Ball joint	1
5.	Large washer	2
6.	3/4"-16 jam nut	2

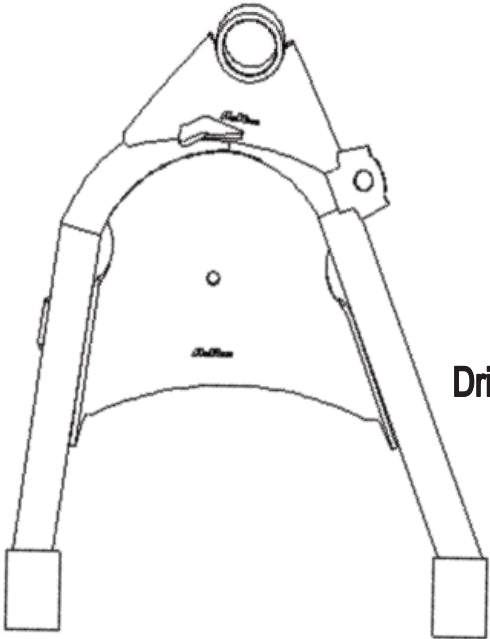
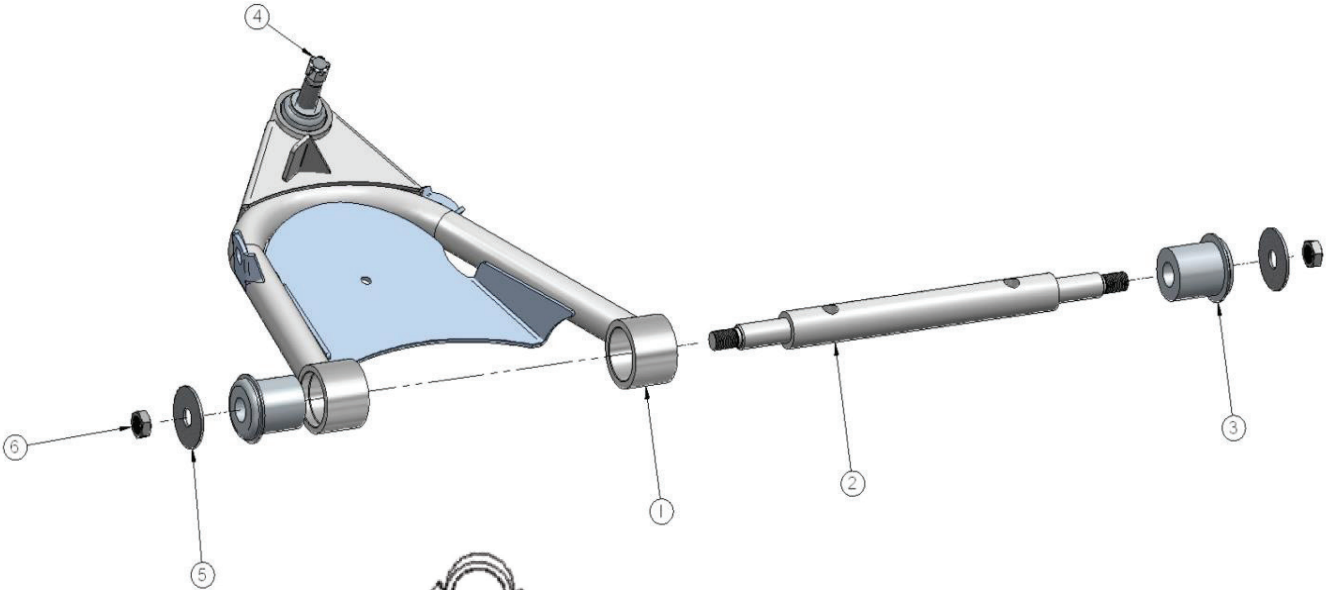

Driver Side - Top View



Part # 11343699⁽⁶³⁻⁷⁰⁾/11353699⁽⁷¹⁻⁷²⁾ - C10 StrongArms

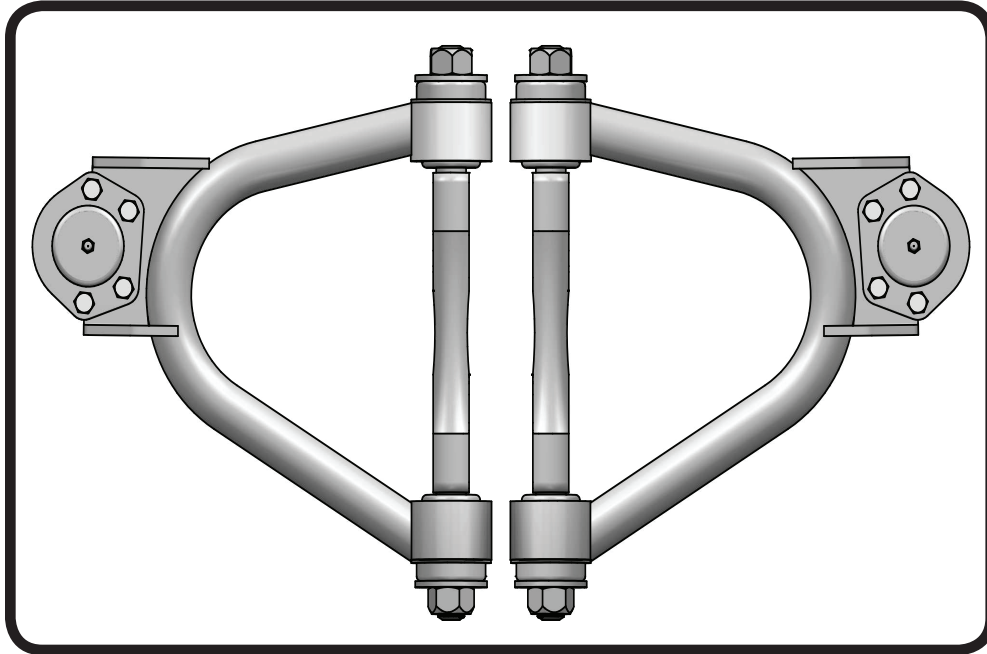

Recommended Tools

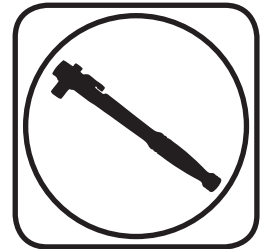

**C-10 CoolRide Upper StrongArms
Installation Instructions**

Table of contents

- Page 6..... Included components
- Page 7..... Installation



Upper Control Arm ComponentsIn the box

Item #	Part Number	Description	QTY
1	90000911 Kit/90000902 Kit	(63-70/71-72) - Upper Balljoint Assembly	2
2	90000911 Kit/90000902 Kit	5/16"-24 x 1" Hex Head Bolt	8
3	90000911 Kit/90000902 Kit	5/16" Lockwasher	8
4	90000911 Kit/90000902 Kit	5/16"-24 Hex Nut	8
5	90000508	Driver Upper Control Arm (Shown)	1
5	90000509	Passenger Upper Control Arm	1
6	90000920	Control Arm Bushing	4
7	90000721	Upper Control Arm Shaft	2
8	99752005	3/4"-16 Locknut	4
9	99753002	3/4" Flat Washer (2" Diameter)	4

Driver Side Shown

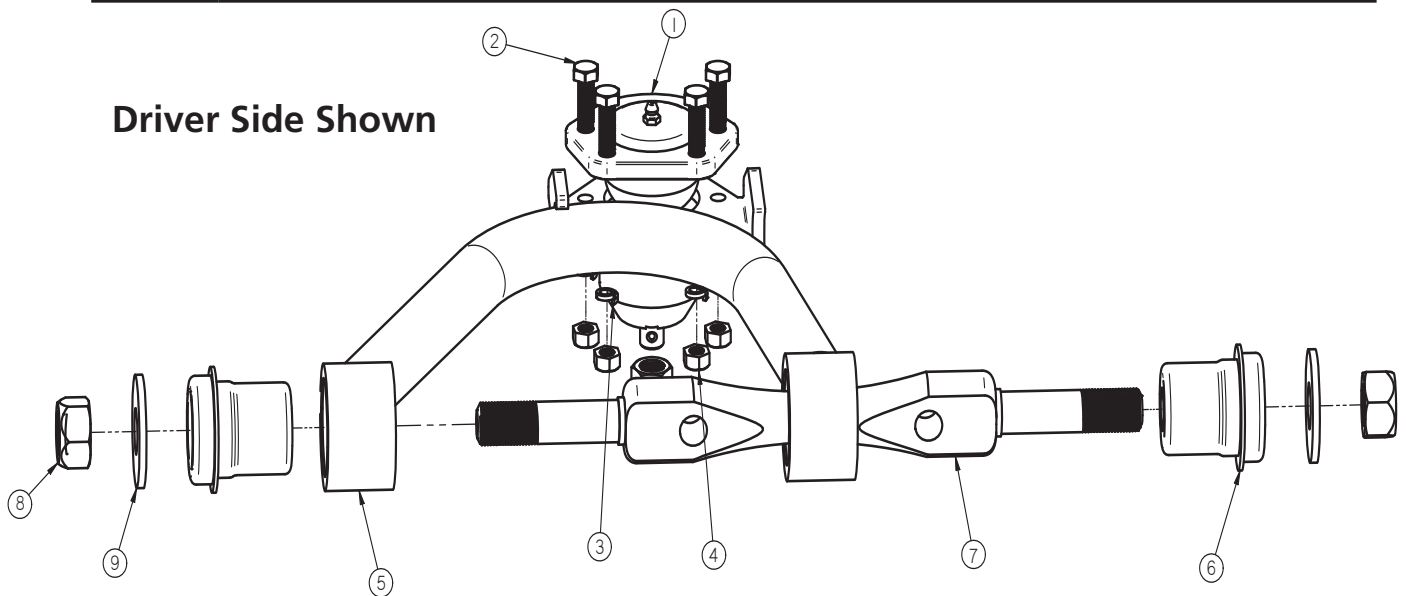

Getting Started.....

Note: The 63-87 C-10's have similar control arms through the years, but the balljoints used were different. The year breaks are as follows: 63-70, 71-72, 73-87. Be sure to use the correct balljoint for the year of spindle you are using.

Balljoints:

- 63-70:** Upper-90000911 Lower-90000912
- 71-72:** Upper-90000902 Lower-90000909



Installation

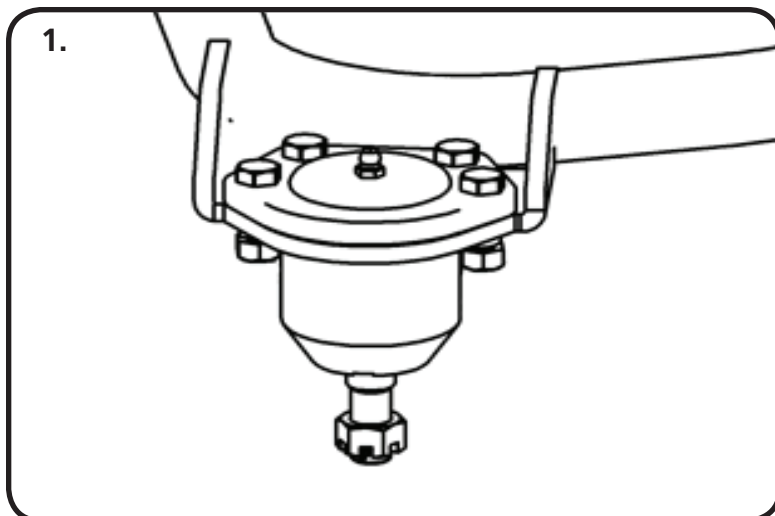

1. Install the balljoints into the upper control arm with the hardware supplied with the balljoint. The upper balljoint goes in from the top side of the control arm. The gussets on the balljoint plate point up.

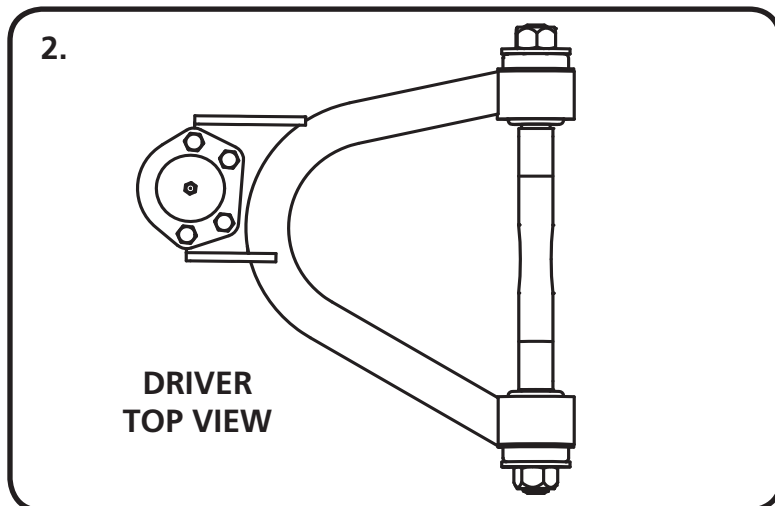

2. Diagram "2" shows the Driver Upper Control Arm. This is looking at the control arm from the top.



3. Remove the OEM upper control arms from the truck. Fasten the control arms to frame using the stock hardware. Reuse the alignment shims; however the truck must be realigned after installation. **With the suspension at mid travel**, the upper cross shaft nuts can be tightened.

4. Grease the upper balljoints.



350 S. St. Charles St. Jasper, In. 47546
Ph. 812.482.2932 Fax 812.634.6632

www.ridetech.com

Part # 11330910
63-72 C10 Front CoolRide Kit
For Use w/ Lower StrongArms

COOLRIDE KIT

Components:

2	90006873	Front air springs – 224c
2	90000060	Upper air spring plate
2	90001083	Medium bump stop – 1.5" tall
2	90000472	Aluminum bump stop extension
1	90000726	Driver side bump stop plate
1	90000727	Passenger side bump stop plate

Hardware:

8	99371004	3/8" x 1 1/4" USS bolt	Upper air spring plate to frame
4	99371001	3/8" x 3/4" USS bolt	Air spring to lower control arm/ bump stop
4	99373005	3/8" lock washer	Air spring to lower control arm/ bump stop
12	99372002	3/8" nyloc nuts	
24	99373003	3/8" flat washers	

SHOCK KIT

Shock:

2	22849999	HQ Smooth Body Shock Cartridge
2	70011138	3/4" ID Shock Bushing
2	90002103	5/8" ID Inner Sleeve

Components:

4	70011140	Stem Bushings
4	70011141	Stem Washers
1	90002301	Driver side upper shock bracket – bolt-on
1	90002302	Passenger side upper shock bracket – bolt-on
2	90000471	Aluminum shock spacer
2	90001619	Shock stud

Hardware:

8	99371004	3/8" x 1 1/4" USS bolt	Upper shock bracket to frame
8	99372002	3/8" USS Nylok nut	Upper shock bracket to frame
16	99373003	3/8" SAE flat washer	Upper shock bracket to frame
4	99372006	3/8"- 24 Thin Jam Nut	Upper Shock Stud

CoolRide Installation Instructions

*****Must be used w/ RideTech shock kit*****



1. Hold the upper plate to the cross member as shown in the picture to the left and clamp to frame. Using the plate as a template drill four 3/8" holes in the cross member.



2. Apply thread sealant to the air fitting and thread into the air spring.

3. Remove the upper plate from the frame and place onto the studs on the top of the air spring. The holes are lettered; **slide the plate to position C** moving the air spring to the front of the vehicle. Secure with 3/8" flat washers and Nylok nuts.

Note: Airline must be routed at this time.



Note: It is acceptable to let the suspension bottom on the air spring. However, if your tire hits the inner fender well before the air spring bottoms out, this bump stop must be installed.

4. The bump stop plate will bolt to the outer two holes of the upper air spring plate. It will hang over the front side of the cross member. It is acceptable to trim the bump stop to achieve maximum drop without the tire rubbing the inner fender well.

5. The break line bracket may need to be tweaked to clear the hose.



6. Fasten the air spring to the lower control arm using a 3/8" x 3/4" bolt, lock washer and flat washer.

7. Check air spring clearance through full suspension travel. **Allowing the air spring to rub will result in failure and is not a warrantable situation.**

8. Ride height on this air spring is approximately 5" tall. The shock absorber should be at about 50-60% travel at this point. Depending on vehicle weight this will usually occur around 80-100 psi.

Shock Installation Instructions

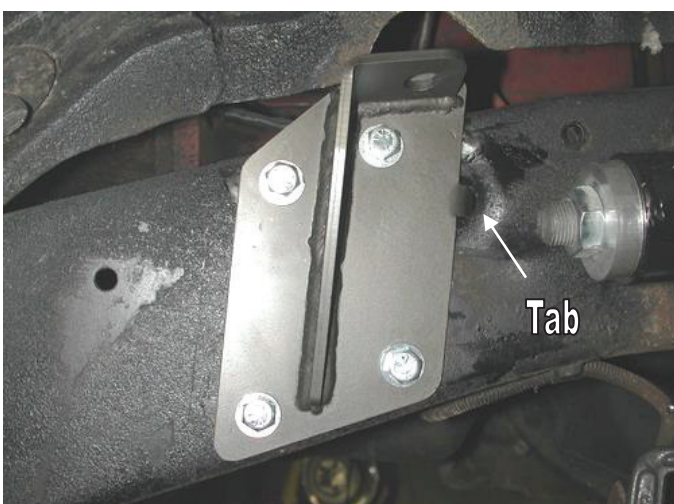

1. Place the new upper shock mount against the frame, the tab in the front of the bracket will slide into the factory shock stud hole. Position the bracket so that the bottom of the bracket is parallel to the bottom of the frame. Using the bracket as a template, mark an drill four 3/8" holes in the frame rail. Secure the bracket to the frame using four 3/8" x 1 1/4" bolts, Nylok nuts and flat washers.



2. Attach the shock to the upper mount using the new rubber bushings and hardware supplied.

Note: A notch must be made in the inner fender well just above the mount to allow clearance for the shock stud.



3. Slide the lower shock stud through shock, then install the aluminum spacer. The step on the spacer will face the lower arm. Secure the stud to the lower arm w/ the ½" flat washer and nut.



Part # 11342699⁽⁶³⁻⁷⁰⁾/11352699⁽⁷¹⁻⁷²⁾ - C10 Drop Spindles

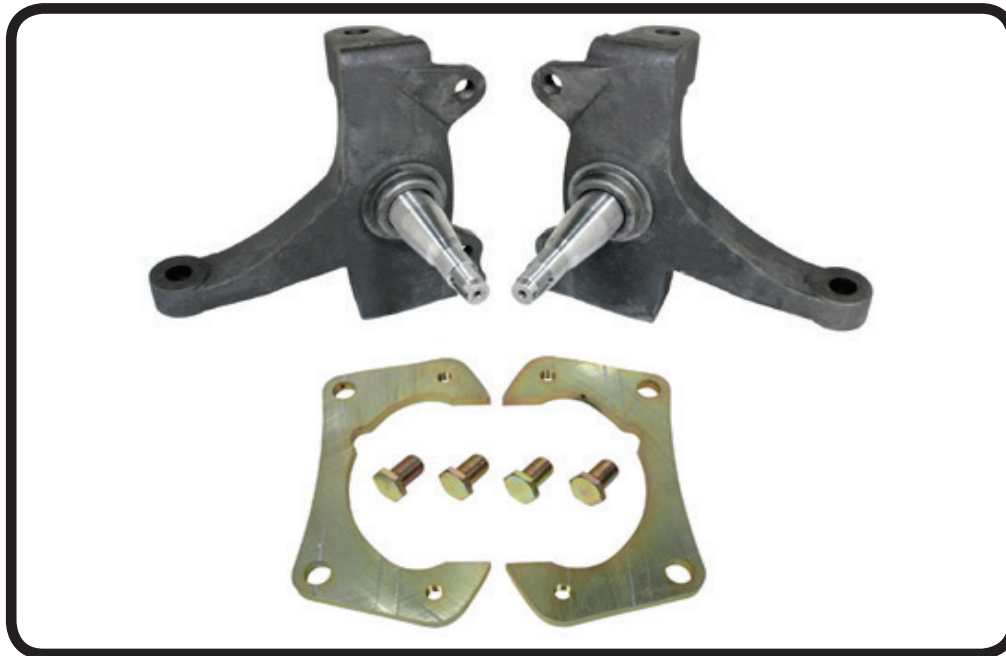

Recommended Tools

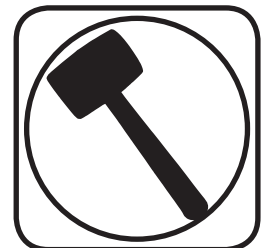
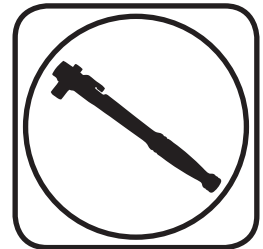

Major ComponentsIn the box

1	11349301/11359301	Pair of drop spindles
1	90001926	Pair of caliper brackets

Installation

Balljoint nut Torque Specs:

Upper: Torque to 50 ft lbs and then tighten nut to align cotter pin hole not exceeding 90ft lbs.

Lower: Torque to 90 ft lbs and then tighten nut to align cotter pin hole not to exceeding 130 ft lbs.

Note: These spindles are setup for 1973-1987 HD Rotor and Caliper. The HD Rotor is 1 1/4" wide.



Part # 11337199 - 1963-1972 C10 Rear StrongArms

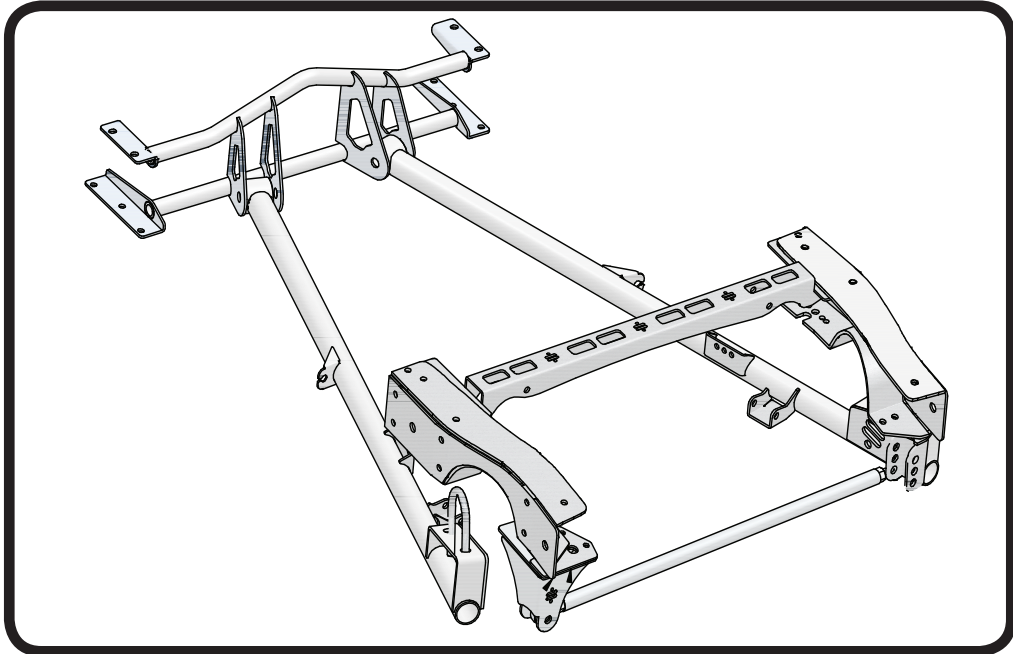

Recommended Tools

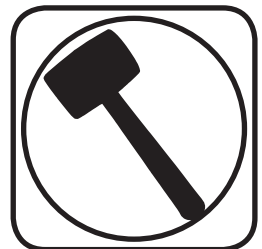

1963-1972 C-10 Rear StrongArms Installation Instructions

Table of contents

- Page 14..... Included components
- Page 15..... Hardware List and Getting Started
- Page 16..... Disassembly and Front Crossmember Installation
- Page 17..... "C" Notch Installation
- Page 18..... "C" Notch Installation
- Page 19..... Installing "C" Notches and Shock Bridge
- Page 20..... Installing StrongArms and Panhard bar
- Page 21..... Installing Panhard bar and Shockwave/CoilOvers
- Page 22..... Finishing



Major ComponentsIn the box

Item #	Part #	Description	QTY
1	90002435	Panhard Mount Top Spacer	1
2	99756001	Trailing Arm U-bolt	2
3	90000626	Driver Side StrongArm	1
4	90000631	Front StrongArm Crossmember	1
5	90002436	Panhard Bar Frame Mount	1
6	90002434	Panhard Mount Bottom Spacer	1
7	70013364	Panhard Bar R-Joint End	1
8	90000627	Passenger Side StrongArm	1
9	90002432	Upper Shock Bridge	1
10	90000614	Passenger "C" Notch	1
10	90000613	Driver "C" Notch	1
11	90002867	Panhard Bar (34 5/8" center to center)	1
	90002062	Shockwave/Coilover Spacers (Not Shown)	8
	90001083	Medium Bumpstop - 1.5" tall (Not Shown)	2
	70013334	Panhard Bar R-Joint Spacers .625 ID x .620" Long (Not Shown)	4
	70013402	R Joint Inner Housing (Trailing Arm R Joint Assembly)	2
	70013408	C10 R Joint End Spacer .625 ID x 1.120" Long	4
	70013279	Spirolox Retaining Ring (Trailing Arm & Panhard R Joint)	4
	70013280	Wavo Wave Spring (Trailing Arm & Panhard R Joint)	4
	70013276	Delrin Snap Over Bushing (Trailing Arm & Panhard R Joint)	4
	70013275	R Joint Center (Trailing Arm & Panhard R Joint)	4

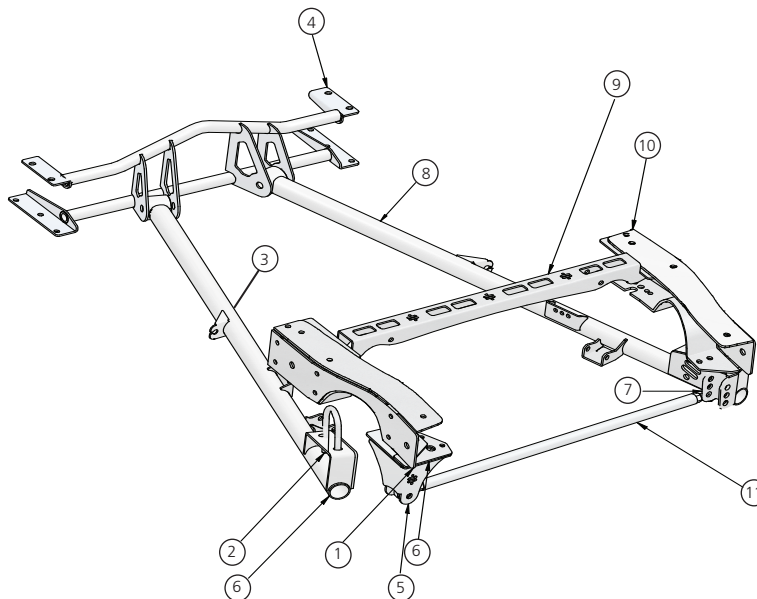



Hardware ListIn the box (Kit# 99010052)

The Hardware Kit contains bags to help aid in selecting the correct hardware for the component being installed. The hardware list shows how the hardware is bagged.

QTY	Part Number	Description	USEAGE
PANHARD MOUNT & PANHARD BAR			
2	99621003	5/8" x 2 3/4" Gr. 8 Bolt	Panhard Bar
2	99622006	5/8" SAE Nylok Jam Nut	Panhard Bar
6	99431012	7/16" x 1 3/4" USS Bolt	Panhard Mount to Frame
6	99432001	7/16" USS Nylok Nut	Panhard Mount to Frame
12	99433002	7/16" SAE Flatwasher	Panhard Mount to Frame
FRONT CROSSMEMBER MOUNTING			
10	99431001	7/16" x 1" USS Bolt	Front Crossmember to Frame
20	99433002	7/16" SAE Flatwasher	Front Crossmember to Frame
10	99432002	7/16" USS Nylok Nut	Front Crossmember to Frame
"C" NOTCH MOUNTING			
4	99621014	5/8" x 1 1/2" Gr. 8 Bolt	"C" Notch to Frame
4	99622001	5/8" SAE Nylok Nut	"C" Notch to Frame
4	99623001	5/8" SAE Flatwasher	"C" Notch to Frame
"C" NOTCH MOUNTING			
6	99431002	7/16" x 1 1/4" USS Bolt	"C" Notch to Frame
12	99431001	7/16" x 1" USS Bolt	"C" Notch to Frame
18	99432001	7/16" USS Nylok Nut	"C" Notch to Frame
36	99433002	7/16" SAE Flatwasher	"C" Notch to Frame
TRAILING ARM TO CROSSMEMBER			
2	99621019	5/8" x 4 1/2" SAE Gr.8 Bolt	Trailing Arm to Crossmember
2	99622001	5/8" SAE Gr. 8 Nylok Nut	Trailing Arm to Crossmember
4	99623001	5/8" SAE Flat Washer	Trailing Arm to Crossmember
SHOCK BRIDGE & SHOCK MOUNTING			
4	99501024	1/2" x 3 1/4" USS Bolt	Shocks to Mounts
4	99502001	1/2" USS Nylok Nut	Shocks to Mounts
6	99431002	7/16" x 1 1/4" USS Bolt	Shock Bridge
6	99432001	7/16" USS Nylok Nut	Shock Bridge
12	99433002	7/16" SAE Flatwasher	Shock Bridge



Getting Started.....

Congratulations on your purchase of the Ridetech Rear Strongarm System. This system has been designed to give your truck excellent handling along with a lifetime of enjoyment. Some of the key features of this system: C-notches to give your truck a lowered stance, long panhard bar to reduce the side to side movement of the differential, double tube front trailing arm crossmember allows the exhaust to be ran through it, new trailing arms to replace old deteriorated trailing arms, and the biggest feature of all, it allows the use of Shockwaves or Coilovers.

Note: These system is designed for use with the Ridetech Shockwaves or CoilOvers and the MuscleBar swaybar. **The factory shocks and springs or the factory sway bar will not fit these arms.**

Note: This kit is designed for trucks with the factory coil spring setup. It can be used on leaf spring trucks if a Coil spring differential is used or the trailing arm mounts are added to the leaf spring differential.

1. Raise the vehicle to a safe and comfortable working height. Let the rear suspension hang freely.
2. Remove the bed.
3. Raise the axle a couple inches and support it so that it cannot rotate. Remove the trailing arms, coil springs, shock absorbers, and panhard bar. Refer to the factory service manual for proper disassembly procedures.

Note: This kit is designed for use with a 1-piece drive shaft.

Disassembly and Front Crossmember Installation

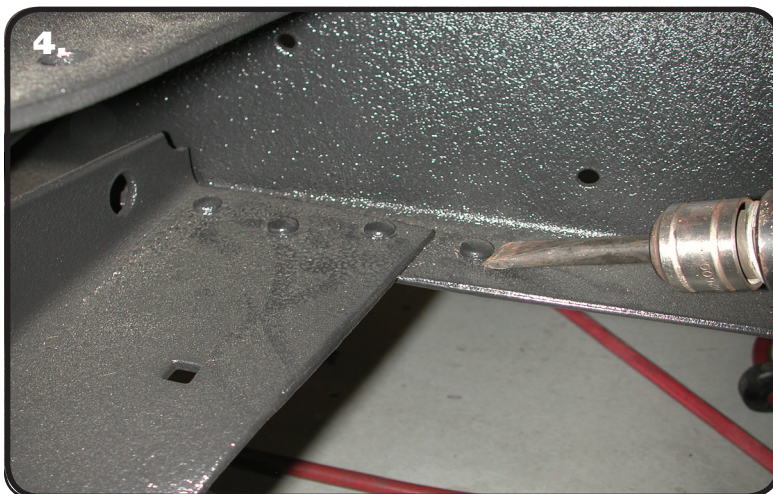

4. The factory trailing arm frame cross member will be replaced with the tubular one supplied. To remove the factory cross member, the rivets must be removed. The easiest method is to chisel them off with an air hammer. Then use a hammer and punch to drive the rivets out.

Note: On each side there is one rivet in front of the cross member and one behind that must also be removed for the new cross member.



"C" Notch Installation

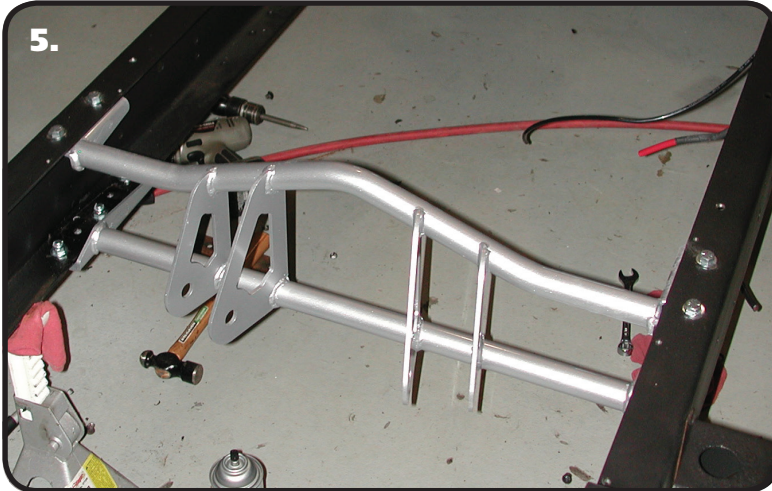

5. Install the new cross member with the trailing arm flanges towards the rear. The cross member is bolted to the bottom side of the frame rails using 10 - 7/16" x 1" bolts, 10 - 7/16" Nylok nuts and 20 - 7/16" flat washers. It may be necessary to enlarge some of the holes with a 7/16" bit.

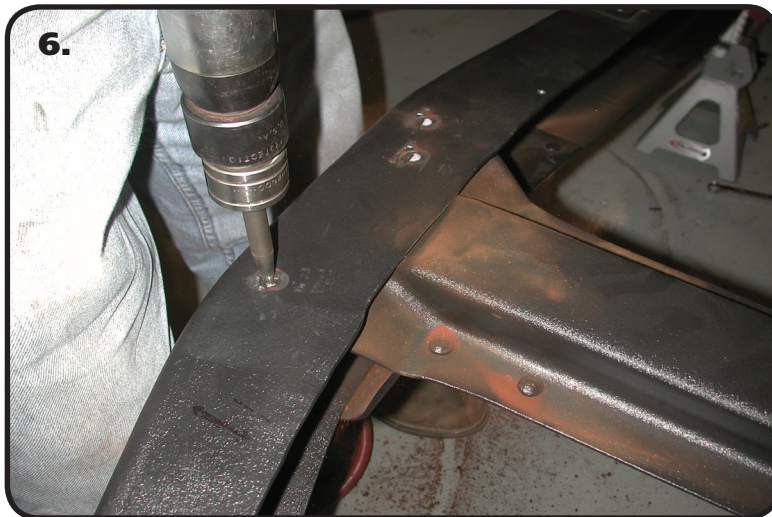

6. The factory upper shock cross member must also be removed to allow for the new upper shock cross member and "C" Notch.



7. On the driver side of the rear frame cross member; these two rivets must be removed before installing the "C" notch. Also, remove the factory panhard mount.



"C" Notch Installation



8. The lower rear rivet on this reinforcement plate must also be removed to mount the notch.

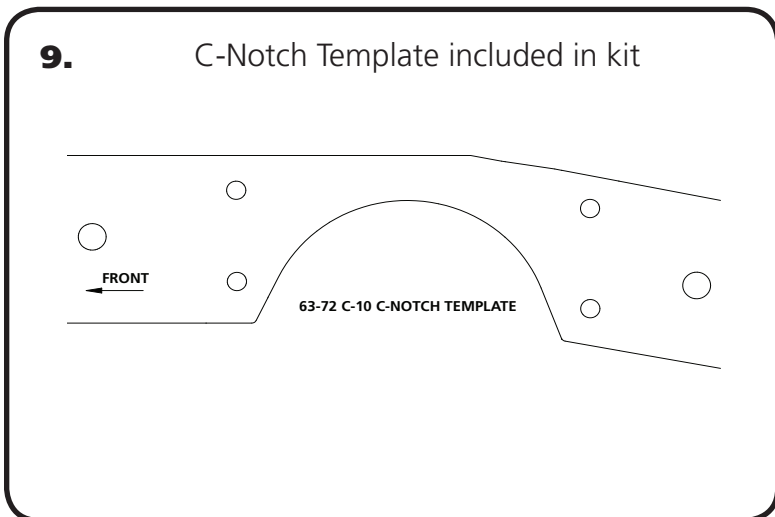

9. Use the supplied "C" Notch template to mark out the frame for cutting. Before cutting out the frame, support the frame in front of and behind the "C" Notch area. We suggest doing one side at a time. The "C" Notch template has an arrow pointing to the front of the truck. Use the 5/8" holes to locate the template of the frame.

Note: We have see trucks with only (1) 5/8" hole. If your truck only has one hole, line it up and then, line up the other edge of the template with the frame rail.



10. The original shock crossmember holes will line up with the holes in the "C" Notch. You can use these holes to double check your Notch placement.



Installing "C" Notches and Shock Bridge



11. Slide the "C" Notch over the frame rail. On some trucks there is just one 5/8" hole, on others there are two holes. Insert 5/8" x 1 1/2" bolt, Nylok nut and flat washer in each hole to secure the notch. The factory rivet holes will need to be drilled out with a 7/16" drill bit. Use the "C" Notch as a template to drill the remaining holes. 7/16" x 1" bolts Nylok nuts and flatwashers. Leave the front (3) bolts out of the top of both notches and the (2) bottom rear bolts of the drivers side out for the moment.

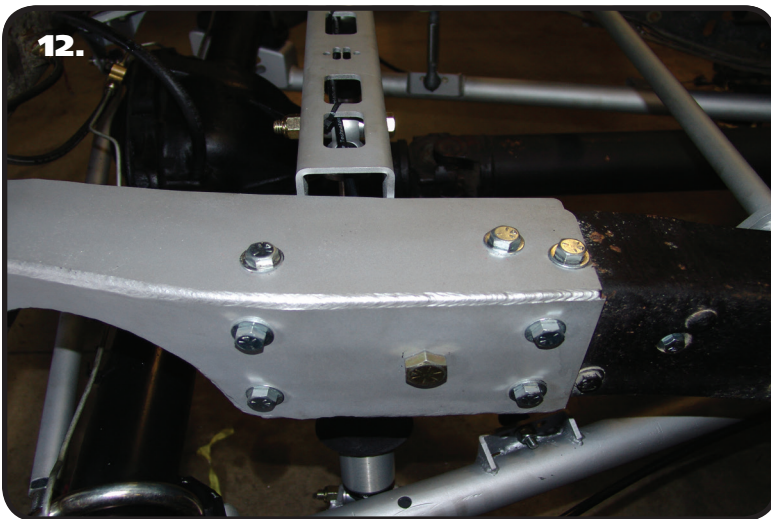

12. Once both "C" Notches are in place bolt in the upper shock bridge. The new upper shock bridge uses the (3) holes in the top of the "C" Notch. The bridge is offset to the rear of the truck, it goes from "C" Notch to "C" notch under neath the top lip of the frame sandwiching the frame between it and the "C" Notch. It is bolted in place using (6) 7/16" x 1 1/4 bolts, Nylok nuts and flat washers.

Note: There are four holes on each side of the bridge; only 3 will be used.

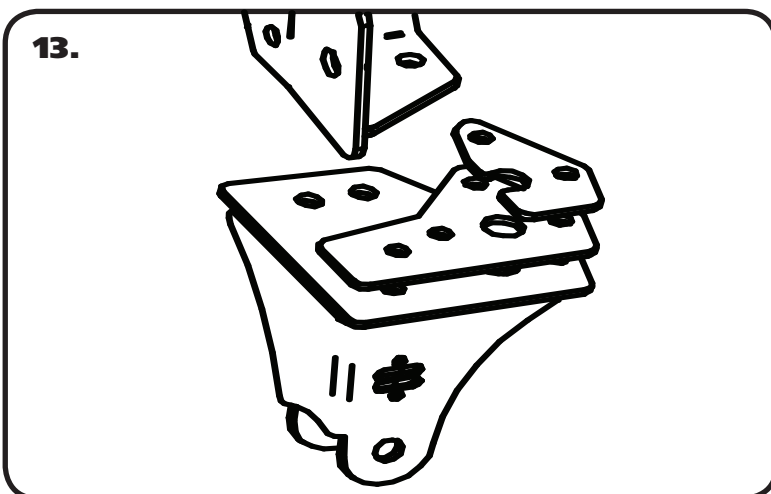

13. Bolt the new panhard mount to the bottom side of the frame on the drivers side. The panhard mount uses (2) spacers to mount it properly (See diagram #13 for reference). The new panhard mount is bolted in place using (6) 7/16" x 1 3/4" bolts, Nylok nuts and flat washers.



Installing StrongArms and Panhard Bar

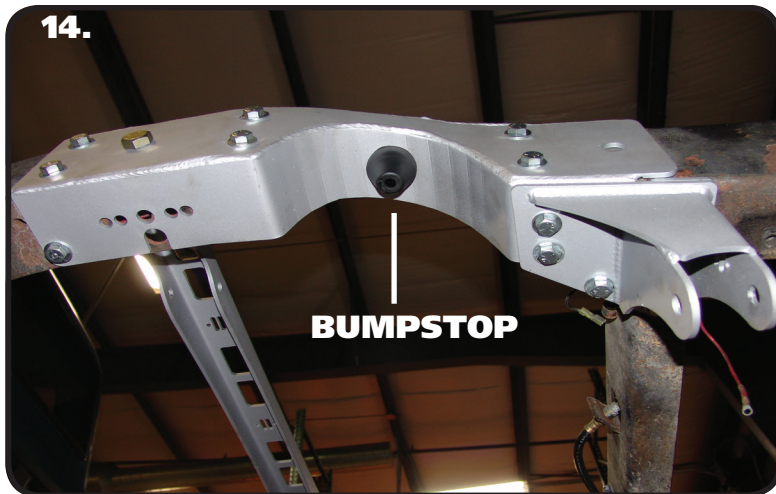

14. Install the bumpstops into the "C" Notch using a 3/8" nut and flatwasher.



15. The StrongArms are a direct replacement of the factory trailing arms and will bolt to the new tubular cross member using two 5/8" x 4 1/2" Bolts, 4 Flat Washers, & 2 Nylok nuts. Insert the R Joint Spacers into each side of the R Joint. These bushings are Delrin and do NOT need lubricating.

Note: There is a driver and passenger side arm. The shock mount will point towards the center of the vehicle. The Panhard mount is on the Passenger StrongArm.

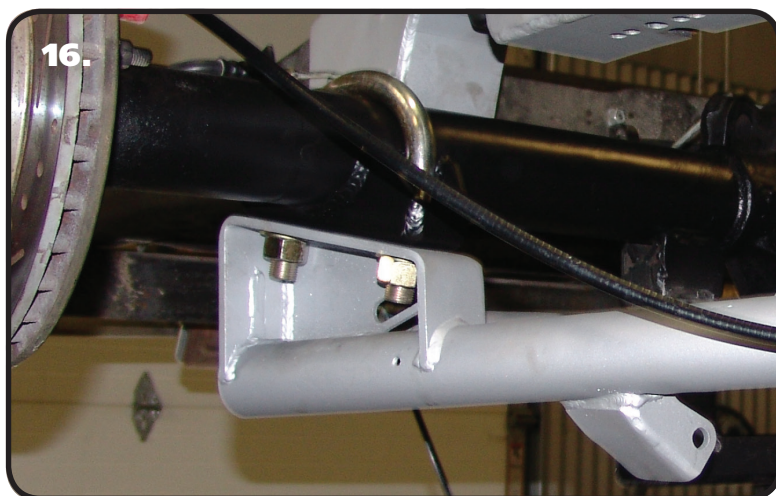

16. Bolt the other end of the StrongArm to the axle using the new U-bolts supplied.



Installing Panhard Bar and Shockwaves/Coilovers

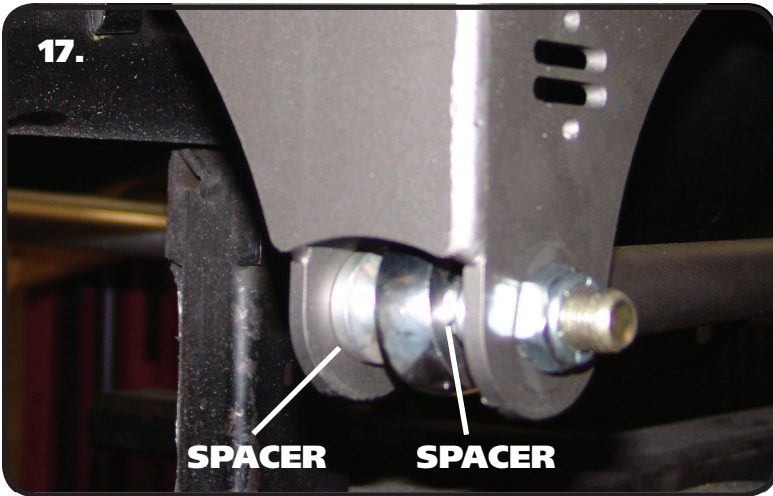

17. Install the Panhard bar into the frame bracket using a 90000552 Spacer on each side of the heim end. The Panhard bar is attached using 5/8" x 2 3/4" bolt and a jam Nylok nut.

Note: The panhard bar is set at 34 5/8" before it is shipped.

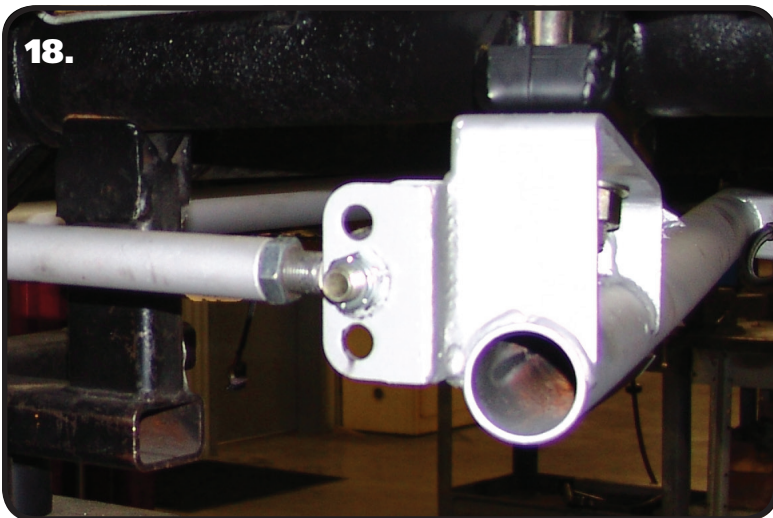

18. Install the other end of the Panhard bar into the bracket on the Passenger StrongArm using a 90000552 spacer on each side of the heim end. The **center** hole is the standard hole. The goal is to keep the panhard bar level as possible at **ride** height. If you decide to run the system higher or lower than the designed ride height the other 2 holes can be used to help keep the panhard bar level at **ride** height.

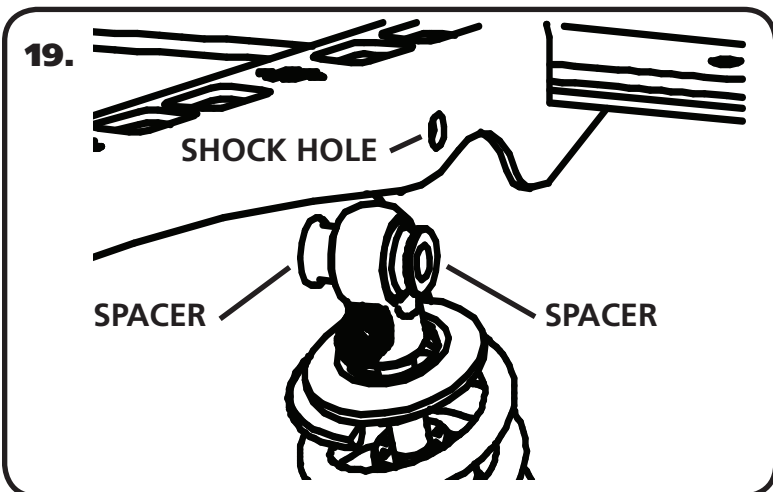

19. Install a spacer on each side of the upper Shockwave/Coilover. Slide the assembly into the upper bridge from the bottom side. If your shock has an adjuster knob position it so that the knob points toward the center of the truck. Line up the hole in the spacers with the hole in the upper shock bridge and insert 1/2" x 3 1/4" bolt and install 1/2" Nylok nut.

Note: If installing Shockwaves and you want to locate the air fitting in a different location, the air spring assembly can be rotated on the shock by grabbing the shock and air spring assembly by hand and spinning the shock in the air spring assembly.



Finishing

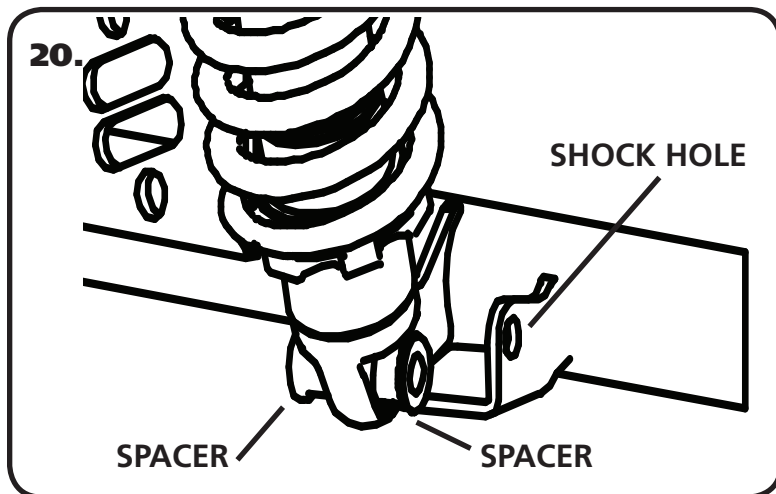

20. Install a spacer on each side of the lower Shockwave/Coilover. Slide the shock with the spacers installed into the mount on the lower StrongArm. You may need to jack the rearend up to line up the holes in the bushing with the 1/2" hole in the shock mounts and hold it in place while you install the 1/2" x 3 1/4" bolt and 1/2" Nylok nut. Tighten the upper and lower shock bolts.

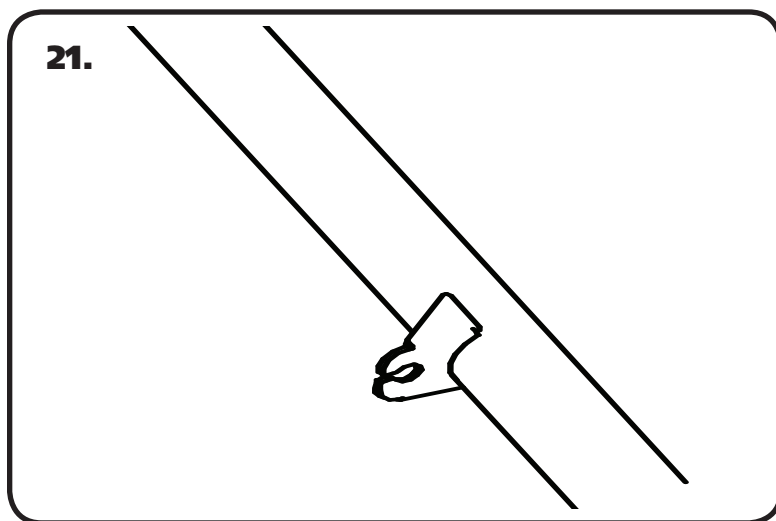

21. The StrongArms have a tab for the emergency brake cable. Install the cable into the tabs and hook the cables back up.

22. Tighten all fasteners. If you are going to install the Ridetech MuscleBar, now is a good time to do it. Reinstall the bed and set the truck back on the ground.

23. Set ride height on the truck. The ride height of the Shockwave/Coilover is approximately 14 1/2". If you are using Shockwaves, this is done by changing the air pressure in the Shockwaves. If you are using Coilovers, the ride height is done by using the adjuster nut for the coil spring. The coil spring on the Coilover will have some preload in the spring to get ride height, this is normal.



Part # 21150801 - 5.2" Stroke HQ Series Shockwave

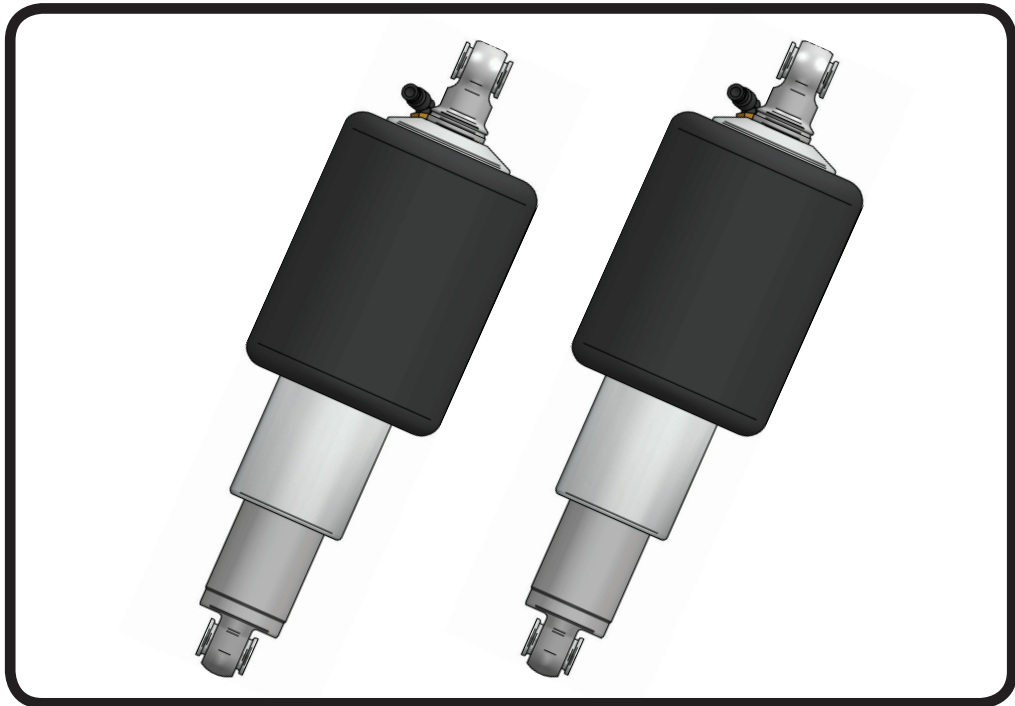

Recommended Tools

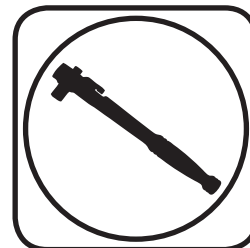
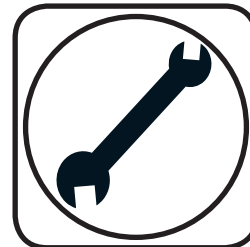

8000 Series Bellow, Eye/Eye 5.2" Shock Installation Instructions

Table of contents

- Page 24..... Included components
- Page 25..... Notes and Care of Your Shockwave
- Page 26..... Shock Adjustment

ShockWave Dimensions:

- Center of bearing to Center of bearing:
- Compressed: 11.85"
- Ride Height: 14.60"
- Extended: 16.42"



Major ComponentsIn the box

Item #	Part #	Description	QTY
1	24159999	5.2" Stroke HQ Series Shock	2
2	90002024	Shock Eyelet	2
3	24090899	8000 Series, 5" Diameter AirSpring	2
4	70010893	AirSpring Locking Ring (Installed on Shock)	2
5	90002044	Spacer kit - 1/2" ID and 5/8" ID	4
	90001994	5/8" ID Bearing (installed in shock and eyelet)	4
	90001995	Bearing Snap Ring (installed in shock and eyelet)	8

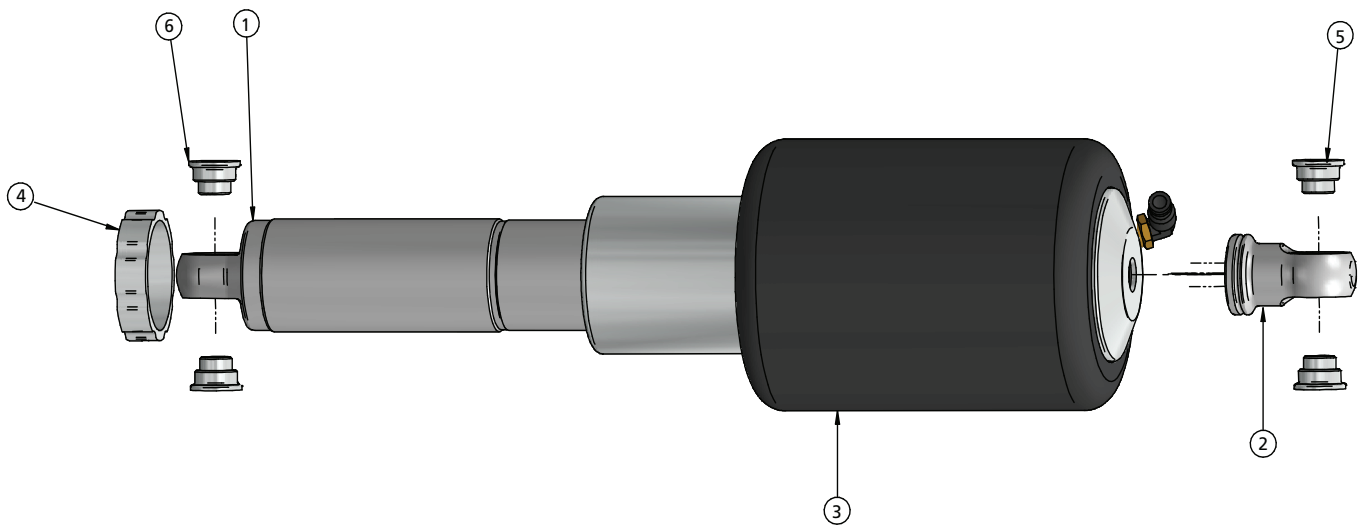

WARNING: ATTEMPTING TO REMOVE THE AIR FITTING WILL DAMAGE IT AND VOID THE WARRANTY.



Notes and Care of your Shockwaves

NOTES:

WARNING: ATTEMPTING TO REMOVE THE AIR FITTING WILL DAMAGE IT AND VOID THE WARRANTY.

You can clock the airfitting location on the ShockWave by turning the AirSpring assembly of the shock. Make sure the fitting doesn't contact the frame.

When cutting the airline, use a razor blade. The cut needs to be a clean cut and square for the airline to seal properly.

The Locking ring on the shock is **NOT** adjustable. These rings are set at the factory to optimize the AirSpring stroke with the shock stroke.

The care and feeding of your new ShockWaves

1. Although the ShockWave has an internal bumpstop, **DO NOT DRIVE THE VEHICLE DEFLATED RESTING ON THIS BUMPSTOP. DAMAGE WILL RESULT.** The internal bumpstop will be damaged, the shock bushings will be damaged, and the vehicle shock mounting points may be damaged to the point of failure. This is a non warrantable situation.
2. Do not drive the vehicle overinflated or "topped out". Over a period of time the shock valving will be damaged, possibly to the point of failure. This is a non warrantable situation! If you need to raise your vehicle higher than the ShockWave allows, you will need a longer unit.
3. The ShockWave is designed to give a great ride quality and to raise and lower the vehicle. **IT IS NOT MADE TO HOP OR JUMP!** If you want to hop or jump, hydraulics are a better choice. This abuse will result in bent piston rods, broken shock mounts, and destroyed bushings. This is a non warrantable situation.
4. Do not let the ShockWave bellows rub on anything. Failure will result. This is a non warrantable situation.
5. The ShockWave product has been field tested on numerous vehicles as well as subjected to many different stress tests to ensure that there are no leakage or durability problems. Failures have been nearly nonexistent unless abused as described above. If the Shockwave units are installed properly and are not abused, they will last many, many years. ShockWave units that are returned with broken mounts, bent piston rods, destroyed bumpstops or bushings, or abrasions on the bellows will not be warrantied.



Shock Adjustment

Shock adjustment 101- Single Adjustable

Rebound Adjustment:

How to adjust your new shocks.

The rebound adjustment knob is located on the top of the shock absorber protruding from the eyelet.

You must first begin at the ZERO setting, then set the shock to a soft setting of 20.



-Begin with the shocks adjusted to the ZERO rebound position (full stiff). Do this by rotating the rebound adjuster knob clockwise until it stops.



-Now turn the rebound adjuster knob counter clock wise 20 clicks. This sets the shock at 20. (settings 21-24 are typically too soft for street use).

Take the vehicle for a test drive.



-if you are satisfied with the ride quality, do not do anything, you are set!

-if the ride quality is too soft increase the damping effect by rotating the rebound knob clock wise 3 clicks. **CONTINUE ON NEXT PAGE.**

Take the vehicle for another test drive.



-if the vehicle is too soft increase the damping effect by rotating the rebound knob clock wise 3 additional clicks.



-If the vehicle is too stiff rotate the rebound adjustment knob counter clock wise 2 clicks and you are set!

Take the vehicle for another test drive and repeat the above steps until the ride quality is satisfactory.

Note:

One end of the vehicle will likely reach the desired setting before the other end. If this happens stop adjusting the satisfied end and keep adjusting the unsatisfied end until the overall ride quality is satisfactory.

STILL HAVE QUESTIONS?

Tech line hours

Monday - Friday

8AM - 6PM (EST) 812-482-2932



Part # 11369100 - 1963-1987 C10 Front MuscleBar

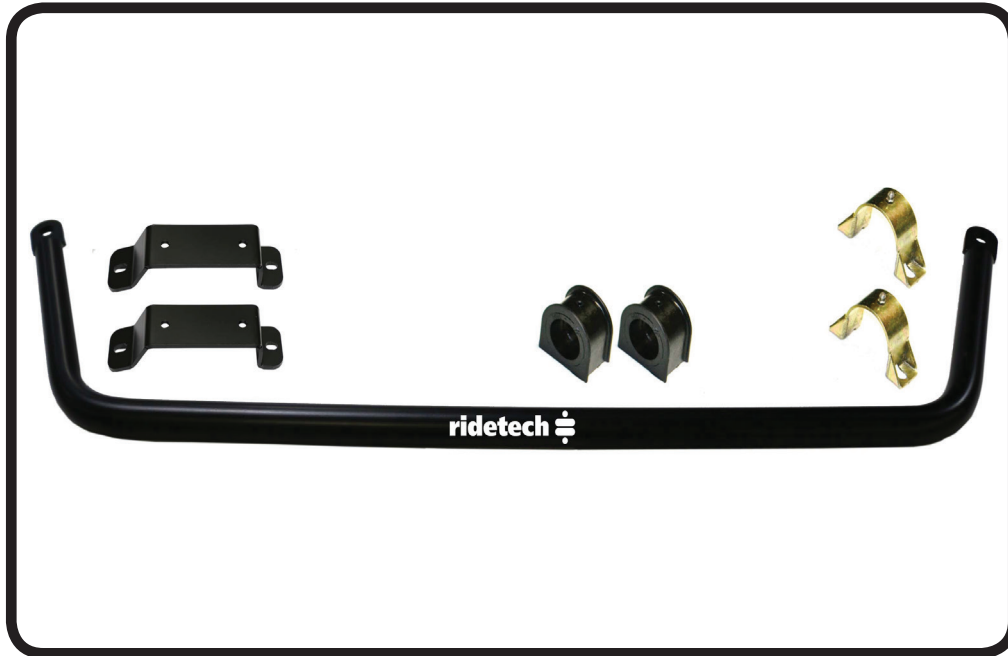

Recommended Tools

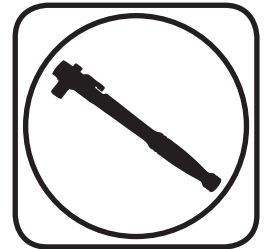

1963-1987 C-10 Front MuscleBar Installation Instructions

Table of contents	
Page 28.....	Included components and Hardware List
Page 29-30.....	MuscleBar Installation
Page 31.....	Final Tightening and Adjusting

THIS MUSCLEBAR IS DESIGNED TO BE USED WITH RIDETECH STRONGARMS.



Major ComponentsIn the box

Part #	Description	QTY
90002768	Front SwayBar	1
	12 mm PosiLink Assemblies (99125001, 90000922, & 90000921)	2
70013130	Delrin Sway Bar Bushing Liner	2
90002513	Bushing Strap	2
70012913	SwayBar Bushing	2
90002591	SwayBar Mounting Bracket	2

HARDWARE KIT #99010050

Part #	Description	Usage	QTY
	SWAY BAR TO FRAME HARDWARE		
99371004	3/8"-16 x 1 1/4" Hex Bolt	Frame & Control Arm Mount	8
99372002	3/8"-16 Nylok Nut	Frame & Control Arm Mount	8
99373003	3/8" SAE Flat Washer	Frame & Control Arm Mount	16
	POSILINK HARDWARE		
99122001	12mm Nylok Nut	PosiLink to Control Arm & MuscleBar	4
99433002	7/16" SAE Flat Washer	PosiLink to Control Arm & MuscleBar	8

Getting Started.....

Install all Front Suspension Components before installing the SwayBar.

If your truck is equipped with an OEM Swaybar, remove it and the Frame Mount to prepare for the MuscleBar installation. The rivets on the frame mount will need to be removed to remove the mount.

This SwayBar kit utilizes a Delrin Liner in the SwayBar Bushing. The Delrin Liner allows the Swaybar to move freely and quietly in the Bushing. The Delrin is self-lubricating, no lubrication is required.



1. Some trucks are equipped with a OEM swaybar. If your truck has one, the OEM mount will need to be removed to install the MuscleBar. This is done by removing the rivets. The rivets can be removed by chiseling the heads off and driving them out or by drilling the rivets out. The new Frame Mount bolts directly in place of the old mount. If your truck doesn't have a sway bar, the mounting holes will still be in the frame.



MuscleBar Installation



2. The MuscleBar Mount attaches to the frame using the holes from the OEM mount. The end of the frame bracket with the angled bends goes forward. Attach the bracket using a 3/8"-16 x 1 1/4" bolt, 3/8"-16 Nylok nut and a 3/8" Flat Washer on top and bottom. The same hardware setup is used in each hole. Repeat on the other side and tighten hardware.



3. The Delrin Liner is split on one side to ease installation. We found it easier to install by opening up the Liner enough to slide it onto the end of the SwayBar, then sliding it into position. It will open up and slide over the curves in the Bar. Install a Liner on each side of the SwayBar in the approximate location they will need to be when installing the SwayBar on the Truck.

Note: The Delrin is self-lubricating, no lubricant is needed.



4. Open up the Poly SwayBar Bushings and install them over the Delrin Sleeves.



MuscleBar Installation

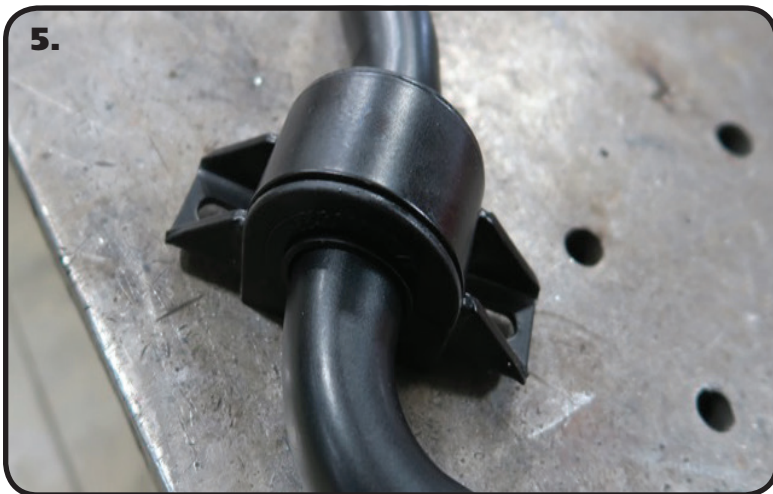

5. Install Bushing Straps Over the Poly SwayBar Bushings.



6. Hold the SwayBar into position on the truck with the SwayBar arms below the tie rods. Align the holes in the Bushing Straps with the holes in the Frame Brackets. Install a 3/8" Flat Washer on (4) 3/8"-16 x 1 1/4" Hex Bolts and insert them into the holes. Install a 3/8" Flat Washer and 3/8"-16 Nylok Nut on each Bolt. Center the bar in the bushings before snugging up the hardware. Do **NOT** completely tighten the Hardware. It will be left partially loose until the End Links are installed.



7. Attach the PosiLinks to the MuscleBar and StrongArm using a 7/16" SAE Flat washer on each side of the arm on the MuscleBar and each side of the bracket on the StrongArm. The 90 degree PosiLink needs to be installed with the **THREADS POINTING IN TOWARD THE FRAME**. Install 12mm Nylok nut on each posilink and tighten down. Torque to 50 ftlbs.

8. Tighten the bolts attaching the bushings bracket to the frame. After installation, be sure that the Musclebar will go through the entire suspension travel without contacting anything