



350 S. St. Charles St. Jasper, In. 47546
Ph. 812.482.2932 Fax 812.634.6632

www.ridetech.com

Part # 30154700
Big Red Analog Compressor Kit

Components:

2	31920020	Thomas compressor
1	31915100	5 gallon aluminum air tank
1	31937401	Big Red air valve block
2	90000404	Mounting bracket for Big Red valve
1	31980005	135/150 psi pressure switch
1	31194000	4 way analog control panel – Black Face

Wiring:

2	31900035	Valve harness – 10'
2	90001922	20 amp fuse
2	90001924	Fuse holder
2	31900022	Relay w/ harness
2	90001918	Female spade terminal
3	90001916	Ring terminal
3	90001913	Butt Connector

Airlines & Fittings:

1	31940004	40' roll of 3/8" DOT airline -- compressor system, air springs
2	31940000	25' roll of 1/8" DOT airline – valve block to gauges
1	31956004	3/8" hex pipe plugs – extra supply port
3	31956201	3/8" tube x 1/4" pipe 90 elbow DOT
2	31956000	3/8" tube x 1/4" straight DOT
3	31957004	1/4" pipe plug
5	31956600	3/8" x 3/8" elbow fittings
4	31952000	1/8"npt x 1/4" tube straight fitting
2	31957003	2" long 1/8"npt splice
2	31956102	1/8"npt female x 3/8" tube airline fitting, straight
1	31959301	1/4" npt check valve- Screws into tank for compressor line
1	31956400	3/8" Tee Fitting

Hardware:

4	99251001	1/4" x 1/2" USS bolts – valve block bracket
4	99253001	1/4" lock washers – valve block bracket
6	99104001	10-24 x 1" phillips screw
6	99102002	10-24 Nylok nut
6	99103001	#10 SAE flat washer

**THE CHECK VALVE SUPPLIED SCREWS INTO THE AIR TANK WITH AN AIR FITTING
THREADING INTO IT. THE COMPRESSOR LINE WILL FEED INTO THE CHECK VALVE.**



350 S. St. Charles St. Jasper, In. 47546

Ph. 812.482.2932 Fax 812.634.6632

www.ridetech.com

30154700 Compressor System Instructions

These are some general guidelines to follow when installing your new RidePro air control system. Depending on the vehicle there are many different ways to plumb the system. Start out by planning a lay out of where you want everything to be mounted. Typically we try to keep the compressor, solenoids, tank, and sending units in a central location, but they can be separated to suit your needs.

Mounting the Compressor/ Pressure Switch

- **Remove the negative battery cable before beginning installation.**
- All of our compressors are sealed for moisture and dust resistance so they can be mounted anywhere on the vehicle. Although it is best to mount it in a place out of direct contact with rain and snow. It is OK to mount it underneath the vehicle but keep it inside the frame rails away from water and debris thrown off the tire.
- This is a dry compressor; therefore it is maintenance free and can be mounted in any position.
- It is best if mounted to something solid to reduce vibration and noise. If mounting it to sheet metal or the bed of a truck, use sound deadening material between the compressor and the mounting surface.
- Use the rubber grommets supplied on the feet of the compressor to reduce vibration.
- Apply thread sealant to the pressure switch and screw into the tank.
- 20 amp fuses/holders are supplied and must be installed within 1 ft. of the battery.

Mounting the Air Tank

- The air tank can be mounted anywhere on the vehicle in any position.
- A template is supplied to aid in drilling the holes. Check the template with the tank before drilling the holes.
- If your air system is used frequently you may want to remove the tank once a season to drain any excessive accumulation of water.

Mounting the RidePro Air Valves

- The valves, like the compressor, are sealed and can be mounted in the same locations. Although if the vehicle will be exposed to freezing temperatures it is a good idea to mount them in the engine bay if possible to reduce the possibility of freezing.
- They can be mounted in any position.
- Mount the valves higher than the tank to avoid moisture build up. This could cause the air pressure sensors to give a faulty reading.
- Attach the ground strap to a good, clean ground (preferably the frame).
- The exhaust port will be left open.
- The valve is held closed with the pressure in the tank. If tank pressure drops below air spring pressure they will equalize deflating all 4 air springs.

Wiring Harness

- Red Wire- The red wire on the harness will connect to 12 volt switched.
- Gray Wire- This power for the light in the switch- this wire goes to the light circuit(dash lights) of the vehicle. This wire needs 12 volt when the lights are on or the key is on. The gauge light should be hooked to the same circuit as this wire.
- Black Wire- This wire is ground for the light in the switch. It goes to a good ground.

Routing the Airline and Fittings

- Make all airline cuts with a razor or tubing cutter. It must be clean and straight or it will not seal.
- All fittings are DOT approved push-to-connect style. They are very simple to use and are reusable. Firmly push the airline into the fitting to attach. To release the airline pull the collar on the fitting back towards the fitting and pull the airline out.
- Use thread sealant on all fittings.
- Do not over tighten the fittings. This could result in breaking the fitting or damaging the air spring.
- All of our airlines are DOT approved so they are very strong. But keep them away from any sharp edges. Also when passing through a hole in the frame use a grommet.
- Keep away from intense heat including mufflers and exhaust manifolds.
- Use zip ties or other fasteners to secure the airline.

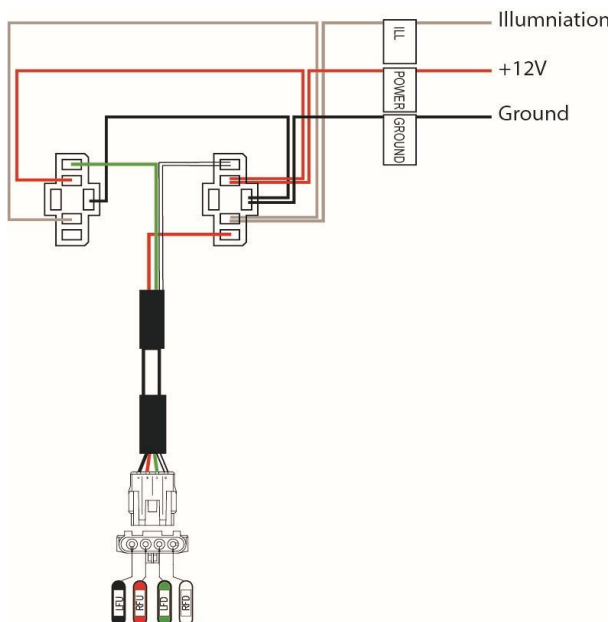

Illumination (Gray) - This wire provides power to the switch lights. It should be hooked up to a light circuit in the vehicle (dash lights) or it can be hooked up to a 12 volt switched source.

+12V (Red) - This wire is the main power for the valves. It should be hooked up to a 12 volt switched circuit. It needs 12 volt with the key on and should have no power with the key off.

Ground (Black) – This wire provides ground to the switch lights. It should be hooked up to a good ground source.

Note: The Illumination and Ground wires do not have to be hooked up for the switches to work. They

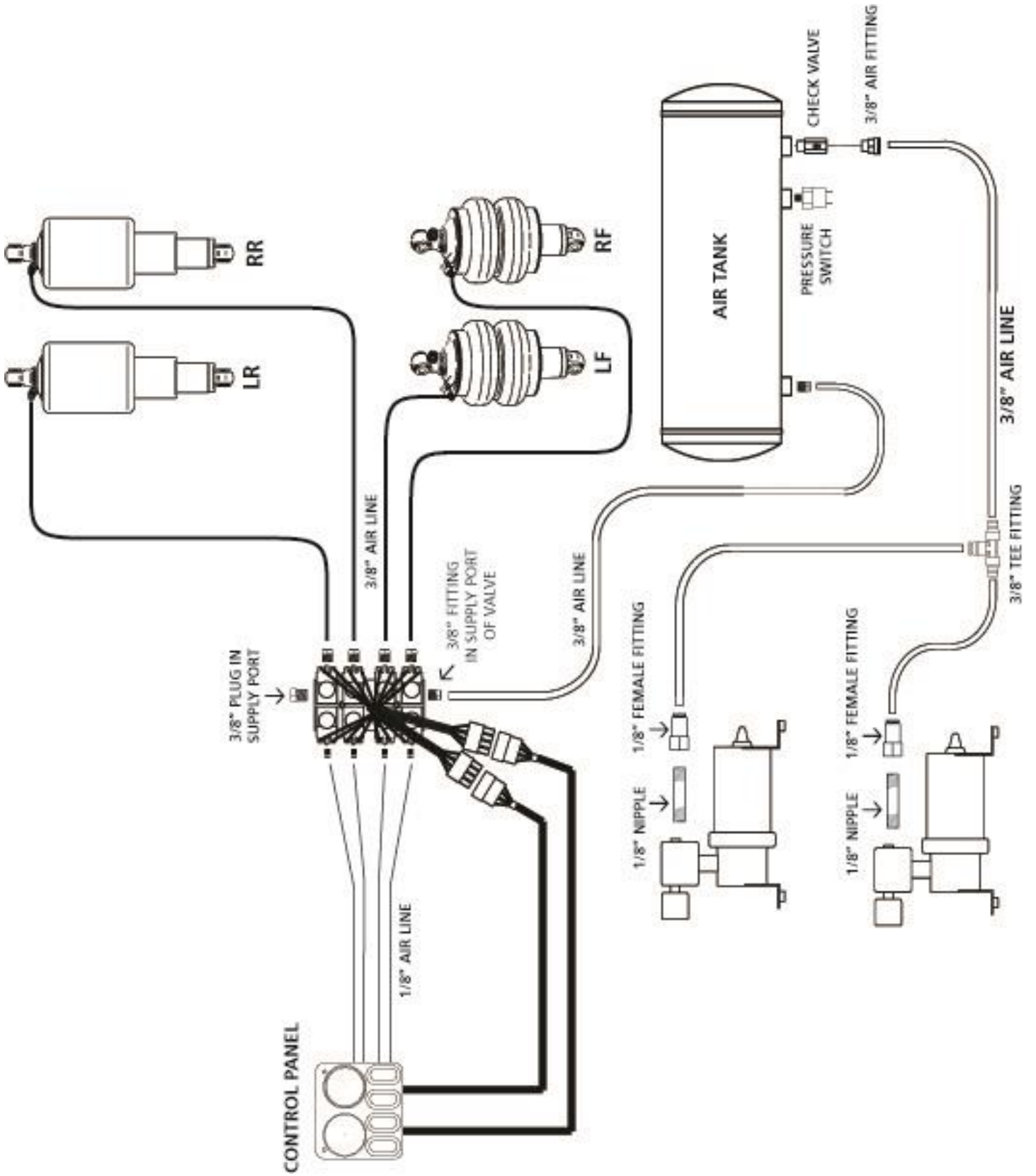

Dual Compressor Wiring Diagram

