



350 S. St. Charles St. Jasper, In. 47546  
Ph. 812.482.2932 Fax 812.634.6632

[www.ridetech.com](http://www.ridetech.com)

**Part # 11040201**  
**58 Impala HQ CoilOver Suspension System**

**Front Components:**

1	11053510	HQ Series Front Coilovers
1	11052899	Front Lower StrongArms
1	11053699	Front Upper StrongArms
1	11059100	Front MuscleBar

**Rear Components:**

1	11054699	Rear Coil Spring Kit for StrongArms
1	11050701	HQ Series Rear Shocks
1	11054499	Rear Lower StrongArms
1	11066699	Rear Upper StrongArm
1	11059102	Rear MuscleBar

**Components:**

1	85000000	Spanner Wrench
---	----------	----------------



350 S. St. Charles St. Jasper, In. 47546  
Ph. 812.482.2932 Fax 812.634.6632  
[www.ridetech.com](http://www.ridetech.com)

**Part # 11053510**  
**58-64 Impala HQ Series Front CoilOvers**  
For Use w/ StrongArms

**Shock Assembly:**

- |   |          |                                    |
|---|----------|------------------------------------|
| 2 | 24139999 | 3.6" stroke HQ Series shock        |
| 2 | 90009989 | 2.75" adjustable threaded stud top |
| 2 | 90001994 | .625" I.D. bearing                 |
| 4 | 90001995 | Bearing snap ring                  |

**Components:**

- |   |          |                                    |
|---|----------|------------------------------------|
| 2 | 59080750 | Coil spring – 8" long / 750 # rate |
| 2 | 90002313 | 2.75" stud top base                |
| 2 | 90002222 | Spring retainer kit                |
| 2 | 90001902 | Aluminum cap for Delrin ball       |
| 2 | 90001903 | Delrin ball upper half             |
| 2 | 90001904 | Delrin ball lower half             |
| 2 | 70010828 | Delrin Spring Washer               |

**Hardware:**

- |   |          |                         |                   |
|---|----------|-------------------------|-------------------|
| 2 | 99562003 | 9/16" SAE Nylok jam nut | Stud top hardware |
|---|----------|-------------------------|-------------------|

# COILOver

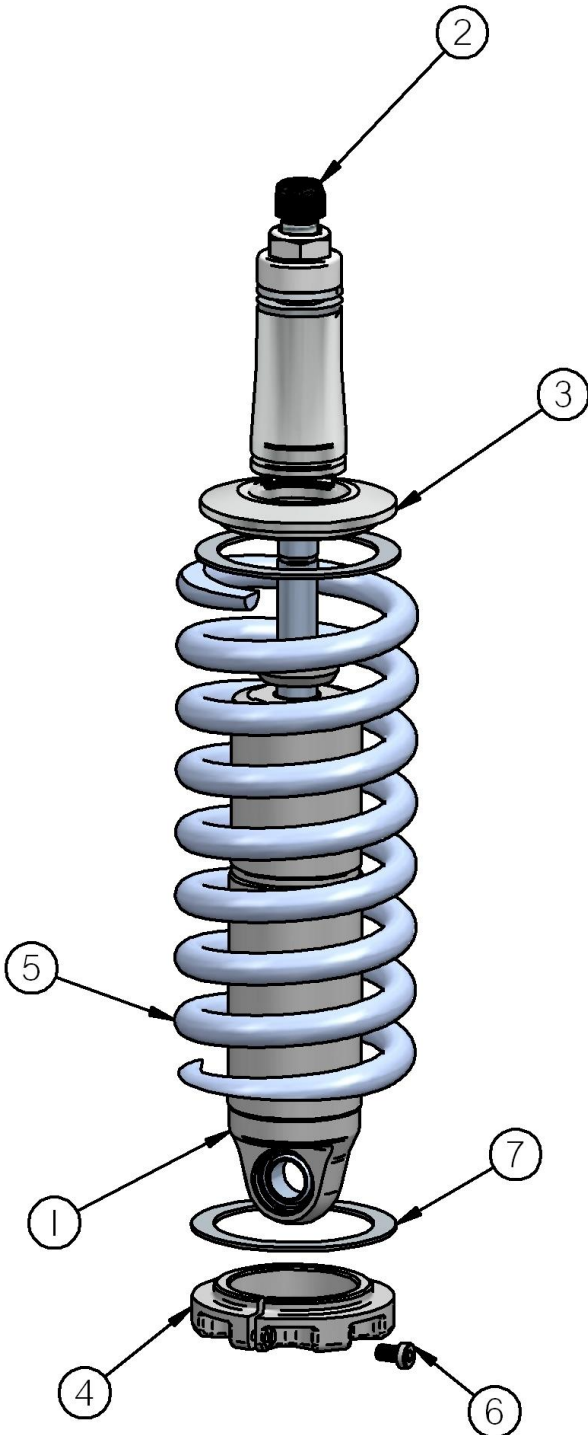

1. Impact Forged, Monotube shock
2. Rebound adjustment knob (SA Only)
3. Upper coil spring retainer
4. Lower coil spring retainer
5. High tensile coil spring
6. Set screw
7. Delrin Spring Washer

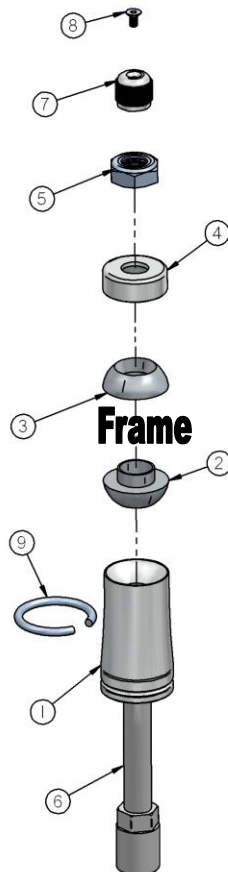

1. Stud top base
2. Lower Delrin ball half
3. Upper Delrin ball half
4. Aluminum cap
5. 9/16" Nylok jam nut
6. Threaded stud
7. Adjustment knob (SA Only)
8. Screw
9. Snap ring

# COILOver

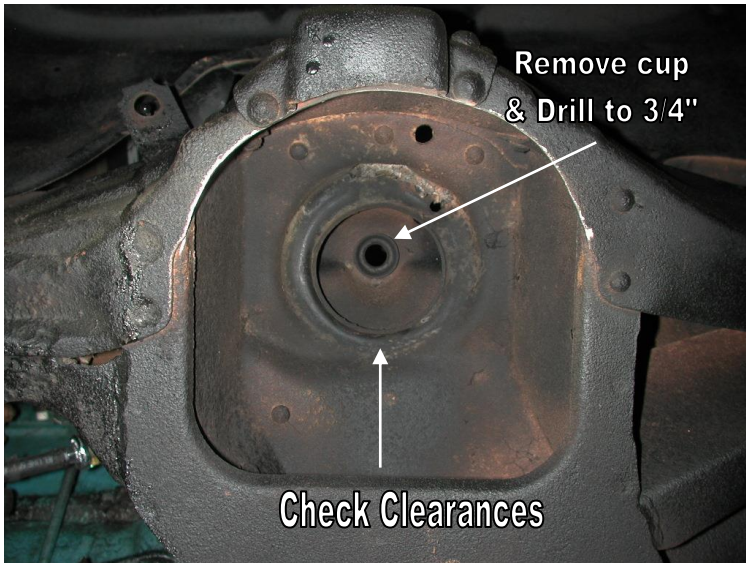

1. To allow the step in the lower Delrin ball half to slide into the factory shock hole, the bushing cup (if your car has one) will need to be removed and the hole may need to be drilled out to  $\frac{3}{4}$ ".

2. Assemble the CoilOver then place into the coil spring pocket w/ the stud and lower Delrin ball sticking through the factory shock hole.

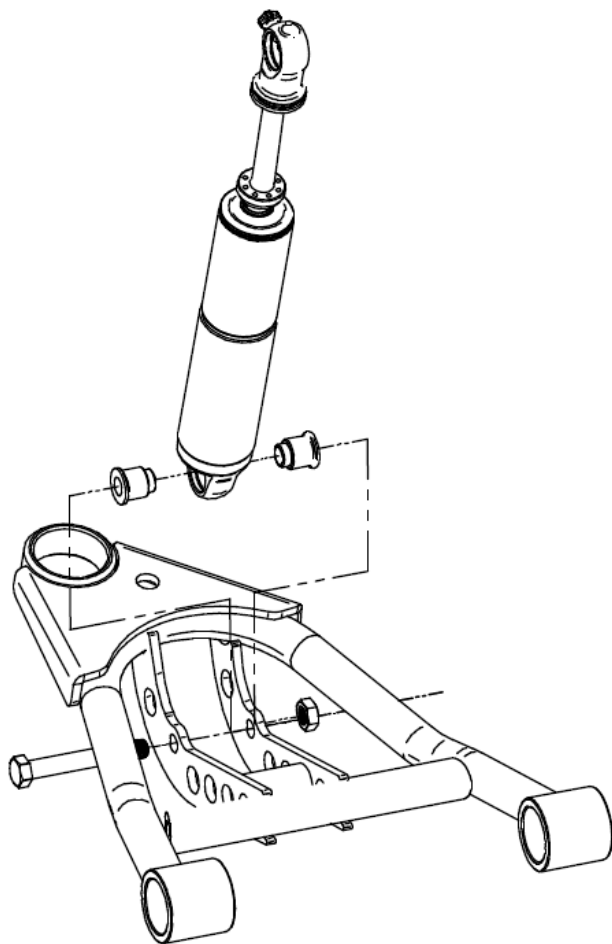

3. Check clearance between the upper factory spring retaining lip and stud top base. Allowing this to hit could cause the shock to break, this

4. Place the upper Delrin ball over stud, then the aluminum cap. Secure the assembly w/ the 9/16" Nylok jam nut.

5. Attach the bottom of the shock to the lower StrongArms using the spacers and hardware supplied w/ the arm.



350 S. St. Charles St. Jasper, In. 47546  
Ph. 812.482.2932 Fax 812.634.6632

[www.ridetech.com](http://www.ridetech.com)

**Part # 11052899**  
**58-64 Impala Front Lower StrongArms**  
For Use w/ Shockwaves or CoilOvers

**Components:**

1	90000474	Driver side lower Arm
1	90000475	Passenger Side Arm
2	90000676	Cross shaft
2	90000677	Cross shaft clamp
4	90000906	Lower control arm bushing
1	90000476	Driver side steering stop
1	90000477	Passenger side steering stop
2	90002586	Ball joint
4	90002062	Aluminum bearing spacer
2		Grease Fittings

**Hardware Kit:**

2	99371011	3/8" x 6 1/2" USS bolt	Sway bar end link
2	99372002	3/8" USS Nylok nut	Sway bar end link
4	99311001	5/16" X 1" USS bolts	Steering stop to lower arm
4	99313002	5/16" SAE flat washer	Steering stop to lower arm
4	99312003	5/16" Nylok Nut	Steering stop to lower arm
4	99431004	7/16" x 2" SAE Gr.8 bolt	Lower arm cross shaft clamp to frame
4	99431006	7/16" x 1 1/4" SAE Gr. bolt	Lower arm cross shaft
4	99503004	1/2" Fender washer	Lower arm cross shaft
8	99433003	7/16" lock washer	Lower arm cross shaft & clamp
2	99501024	1/2"-13 x 3 1/4" SAE Gr. 8 bolt	Shockwave to lower arm
2	99502001	1/2"-13 Nylok	Shockwave to lower arm

# STRONG ARMS™

by Air Ride Technologies

## Installation Instructions

**Note:** These arms will not work with stock 1958 spindles.

1. Raise and support car at a safe, comfortable working height. Let the front suspension hang freely.
2. Remove coil spring, shock absorber, and lower control arm. Refer to factory service manual for proper disassembly procedure.

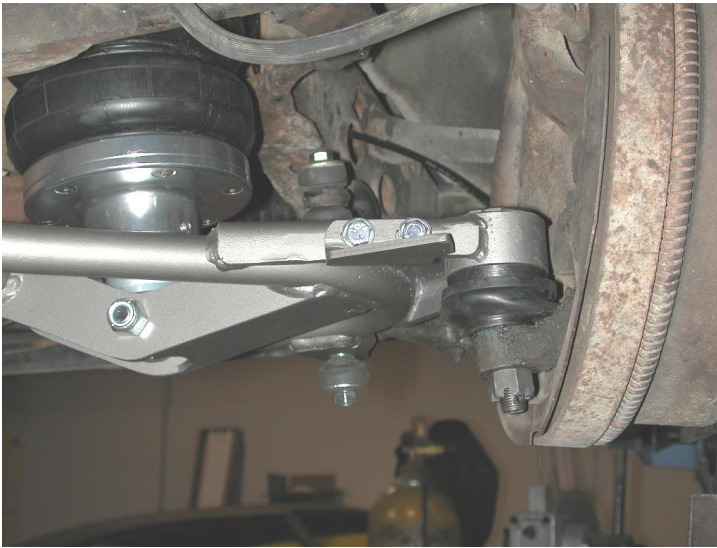

3. Bolt the lower StrongArm shaft to the frame. 7/16" x 2" bolts, lock washers and flat washer will be used to fasten the aluminum clamp to the frame.

4. Slide the ball joint boot over the ball joint stud. Slide the stud through the spindle, secure assembly w/ new castle nut and cotter pin supplied.

5. Attach the adjustable steering stop to the lower arm using two 5/16" x 1" bolts. This can be adjusted to maintain tire/shock clearances.



6. Attach the ShockWave to the lower StrongArm using the 1/2" x 3 1/4" bolts and aluminum spacers provided.

7. The sway bar end link must be shortened to 2" tall optimize clearance and alignment. Use the shorter 3/8" x 6 1/2" bolt supplied. (Discard if using RideTech MuscleBar)

8. Check all clearance with brake lines, airlines, tie rod, sway bar, and tire through full suspension travel and turn wheel lock to lock.

# STRONG ARMS™

by Air Ride Technologies

## 58-64 Chevy Drivers Side Lower Strong Arm

Item #	Description	Qty.
1.	Passenger side arm	1
1.	Driver side arm	1
2.	1/2"-13 Nylok nut	2
3.	Aluminum bearing spacer	4
4.	Cross shaft	2
5.	Aluminum shaft clamp	2
6.	Steering stop bracket	2
7.	Ball joint	2
8.	Cross shaft bushing	4
9.	5/16"-18 x 1" bolt	4
10.	5/16" flat washer	4
11.	5/16"-18 Nylok nut	4
12.	3/8" x 6 1/2" bolt	2
13.	3/8" USS Nylok nut	2
14.	1/2"-13 x 3 1/4" bolt	2
15.	7/16" lock washer	8
16.	7/16"-20 x 2" bolt	4
17.	1/2" fender washer	4
18.	7/16"-20 x 1 1/4" bolt	4

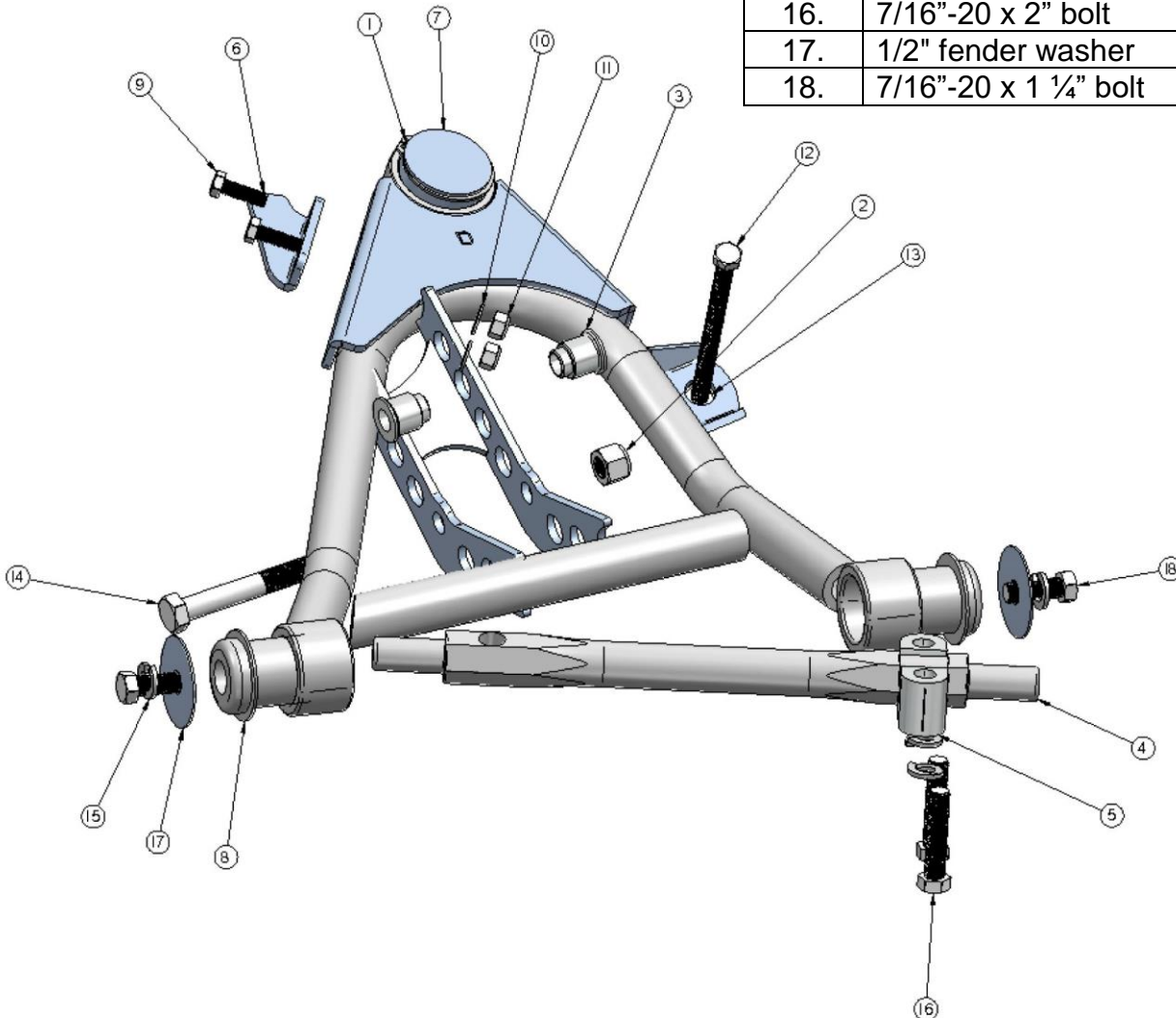



350 S. St. Charles St. Jasper, In. 47546  
Ph. 812.482.2932 Fax 812.634.6632

[www.ridetech.com](http://www.ridetech.com)

**Part # 11053699**  
**58-64 Impala Front Upper StrongArms**

**Components:**

1	90000478	Passenger side Upper Arm
1	90000479	Driver side Upper Arm
2	90000905	Ball Joints
2	90000907	Cross shaft bushing
2	90000927	Upper Cross Shaft

**Hardware:**

4	99371014	3/8" x 1 1/4" SAE Gr. 8 bolt	Upper cross shaft
4	99373001	3/8" Fender washer	Upper cross shaft



# STRONG ARMS™

by Air Ride Technologies

## Installation Instructions



1. Drop the ball joint down through the ball joint plate, secure w/ the hardware supplied.

2. Fasten the upper arm to the frame using the factory hardware. Reinstall the current alignment shims, but **vehicle must be realigned**. This arm was designed with an extra 2 degrees of positive caster allowing the car to be aligned with up to 4 degrees of positive caster. (This will vary from car to car.)

3. Insert the ball joint stud through the spindle and install new castle nut and cotter pin supplied.

### 58-64 Impala Driver Side Upper StrongArm

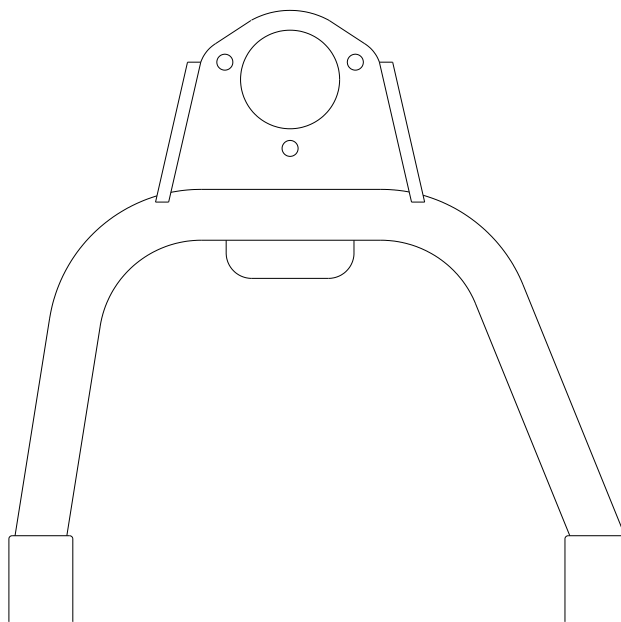

# STRONG ARMS™

by Air Ride Technologies

Item #	Description	Qty.
1.	Passenger side arm	1
1.	Driver side arm	1
2.	Cross shaft bushing	4
3.	Cross shaft	2
4.	Ball joint	2
5.	5/16"-24 x 1" hex bolt	6
6.	3/8"-24 x 1 1/4" hex bolt – Gr. 8	4
7.	3/8" x 1 1/2" washer	4
8.	5/16" lock washer	6
9.	5/16"-24 hex nut	6

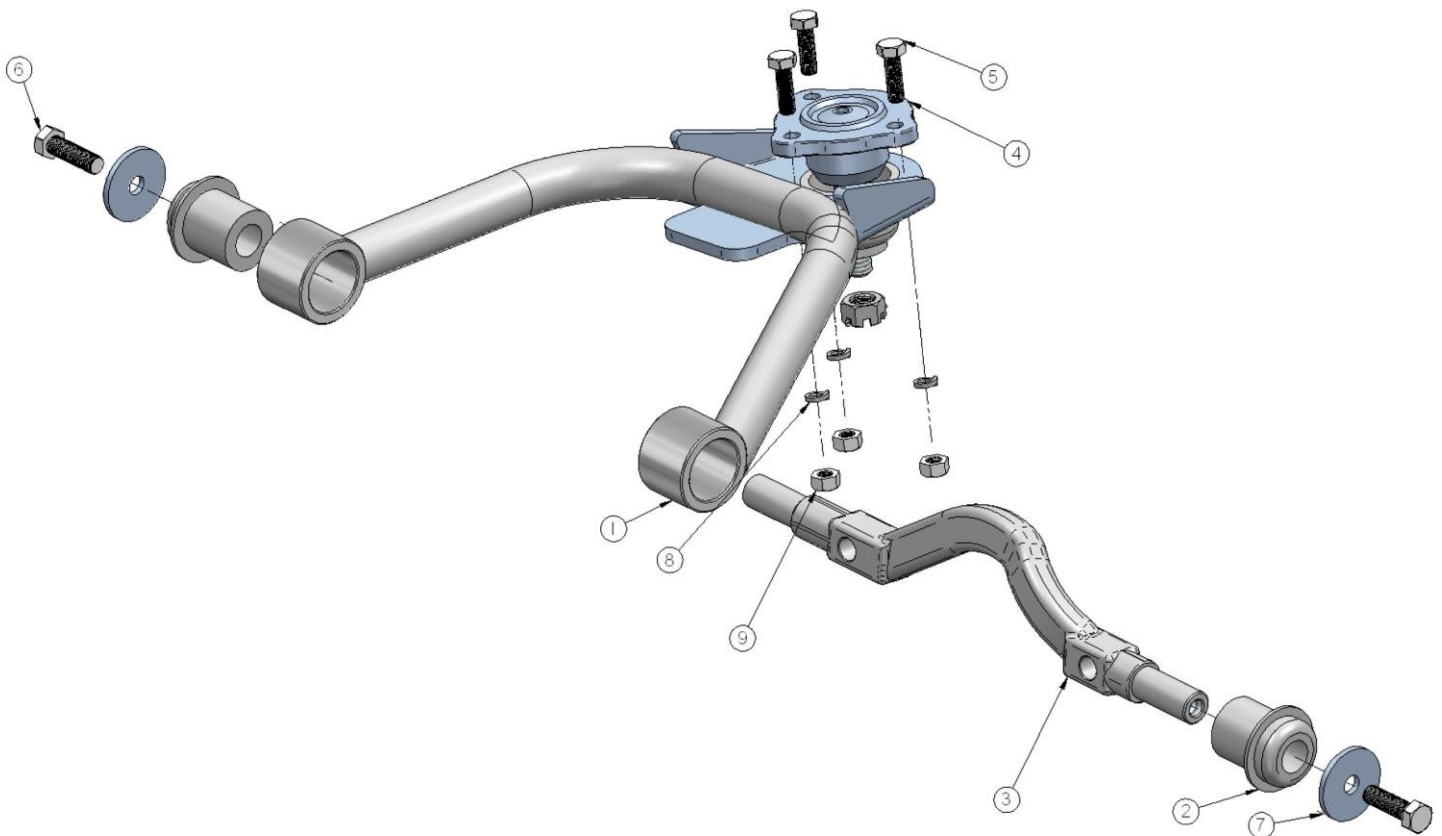



350 S. St. Charles St. Jasper, In. 47546  
Ph. 812.482.2932 Fax 812.634.6632

[www.ridetech.com](http://www.ridetech.com)

**Part # 11059100**  
**58-64 Impala Front MuscleBar**  
w/ PosiLinks

**Components:**

1	90000127	1 ¼" Diameter sway bar	
2	90000124	Sway bar arm	
1	90000736	Driver side frame bracket	
1	90000737	Passenger side frame bracket	
2	90001098	1 ¼" I.D. Polyurethane bushing	
2	90000922	12mm straight PosiLink	
2	90000921	12mm 90 degree PosiLink	
2	90000089	T-bushing for lower control arm	
1	90001092	Tube of lithium grease	
2	99250001	¼" – 28 straight grease fitting	
2	99125001	12 x 1.75 x 45mm stud	In PosiLink (use Loctite)

**Hardware Kit: 99010039**

4	99122001	12mm Nylok nut	PosiLink
2	99433002	7/16" SAE flat washer	PosiLink to lower arm
6	99431001	7/16" x 1" USS bolt	Frame bracket to frame
6	99432001	7/16" USS Nylok nut	Frame bracket to frame
12	99433002	7/16 SAE flat washer	Frame bracket to frame
4	99371003	3/8" x 1" USS bolt	Frame bracket to frame
4	99372002	3/8" USS Nylok nut	Frame bracket to frame
8	99373003	3/8" SAE flat washer	Frame bracket to frame
8	99371017	3/8" x 1" USS button head	Attaches sway bar arm to bar
8	99373005	3/8" lock washer	Attaches sway bar arm to bar

**MUSCLEbar™**

# POSI•Link™

## 11059100 Installation Instructions

\*\*\*\*This sway bar is designed for use with our StrongArms\*\*\*\*

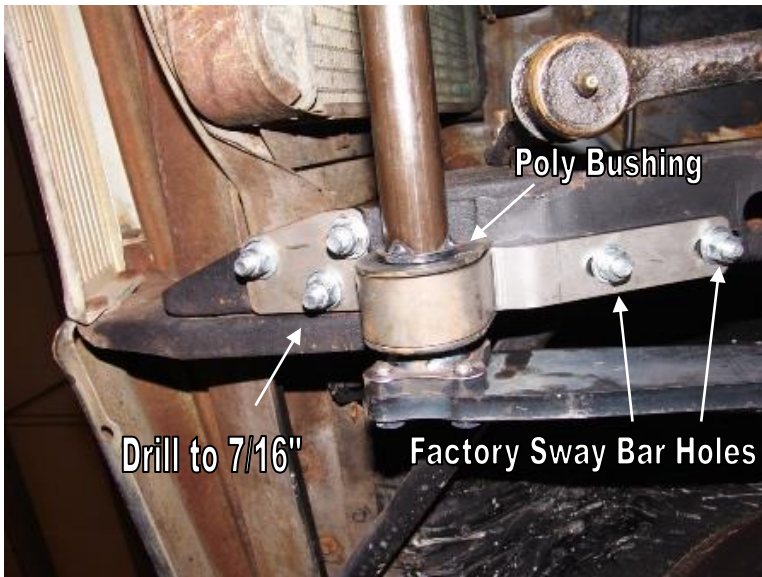

1. Apply lithium grease to the polyurethane bushing and slide it over the sway bar.  
**Note:** Do not use petroleum based lubricants on polyurethane.
2. Place the frame bracket over the poly bushing. Bolt the assembly to the frame, the rear two holes in the bracket will align with the factory sway bar mounting holes.



3. Two of the three holes on the front of the bracket will align with existing holes. The outer hole must be drilled to 7/16".
4. Bolt the sway bar arm to the bar using four 3/8" x 1" button head bolts and lock washers. The holes in the frame may need to be drilled out slightly.
5. Attach the 90 degree end of the PosiLink to the arm using a 12mm Nylok nut.

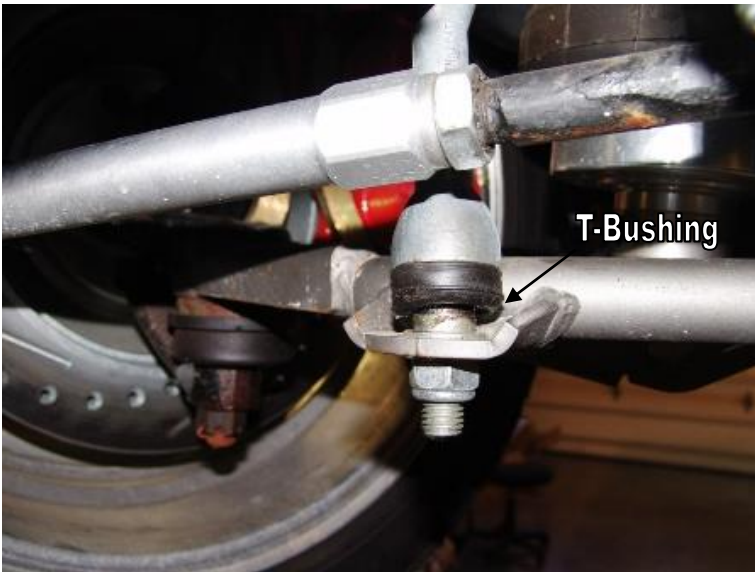

6. Attach the straight end to the lower control arm. A T-bushing is required between the PosiLink and the lower control arm. A 12mm Nylok nut and flat washer will secure the PosiLink to the lower arm.

Check clearance though full suspension travel and turn the wheel lock to lock. Ensure that the PosiLinks do not bind. Check PosiLink clearance with tie rods.



# ridetech

350 S. St. Charles St. Jasper, In. 47546  
Ph. 812.482.2932 Fax 812.634.6632

[www.ridetech.com](http://www.ridetech.com)

Part # 11050701

## 58-64 Chevy Impala Rear HQ Series Shock Kit

### Shock:

2	22989999	HQ Smooth Body Shock Cartridge
2	70011139	5/8" ID Shock Bushing
2	70011138	3/4" ID Shock Bushing
2	90002103	5/8" ID Shock Sleeve
2	90002068	Wide Trunion

### Hardware:

4	99311001	5/16" x 1" USS bolt	Shock to frame
4	99312003	5/16" USS Nylok nut	Shock to frame
8	99313002	5/16" SAE flat washer	Shocks to frame
2	99502002	1/2" SAE Nylok Nut	Shock to lower stud
2	99503001	1/2" SAE flat washer	Shock to lower stud



1. Attach shock T-Bar to frame using 3/8" x 1 1/4" bolts, Nylok nuts and flat washers.



2. Attach the bottom of the shock to factory shock stud using the 1/2" Nylok nut & flat washer supplied. Install one aluminum spacer on each side of the bearing.



350 S. St. Charles St. Jasper, In. 47546  
Ph. 812.482.2932 Fax 812.634.6632

[www.ridetech.com](http://www.ridetech.com)

**Part # 11054499**  
**58-64 Impala Rear Lower StrongArms**  
For Use with CoolRide or Coil Springs

**Components:**

2	90000466	Lower control arm w/ air spring mount
4	90001085	Poly bushing half – 1.5" O.D x 1.5" long
4	90001086	Poly bushing half – 1.5" O.D. x 1" long
4	90000467	Bushing sleeve – 2.5" long

**Hardware:**

4	99621005	5/8" x 3 1/2" SAE Gr.8 bolt	Lower arm
4	99622006	5/8" SAE Nylok	jam nut Lower arm

**Installation Instruction**

1. Raise and support vehicle at a safe and comfortable working height.



2. Fasten the lower StrongArms to the frame and axle using the 5/8" x 3 1/2" bolt and Nylok nuts supplied.

3. Thread the 3/8" x 3/4" bolt with washer and lock washer about half way into the air spring. Slide bolt into slot on lower arm and tighten.

**Note:** Do one side at a time to keep axle from rotating.



350 S. St. Charles St. Jasper, In. 47546  
Ph. 812.482.2932 Fax 812.634.6632

[www.ridetech.com](http://www.ridetech.com)

**Part # 11046699**  
**1958 Impala Rear Upper StrongArm**

**Components:**

- |   |          |   |
|---|----------|---|
| 1 | 90000505 | Rear Upper StrongArm                    |
| 4 | 90001086 | Poly bushing half – 1.5" O.D. x 1" long |
| 2 | 90000549 | Inner bushing sleeve                    |

**Hardware:**

- |   |          |                         |           |
|---|----------|-------------------------|-----------|
| 3 | 99501006 | 1/2" x 3" SAE Gr.8 bolt | Upper arm |
| 3 | 99502002 | 1/2" SAE Nylok Jam nut  | Upper arm |





350 S. St. Charles St. Jasper, In. 47546  
Ph. 812.482.2932 Fax 812.634.6632  
[www.ridetech.com](http://www.ridetech.com)

**Part # 11054799**  
**58-64 Impala Rear Coil Spring Kit**

**Components:**

2	59130375	Coil spring – 13" free length, 5" O.D., 375# rate
2	90002079	Lower spring retainer

**Hardware:**

2	99371001	3/8" x 3/4" USS bolt	Spring retainer to lower arm
2	99373005	3/8" lock washer	Spring retainer to lower arm



1. Attach the spring retainer to the lower trailing arm using the 3/8" x 3/4" bolt and lock washer.

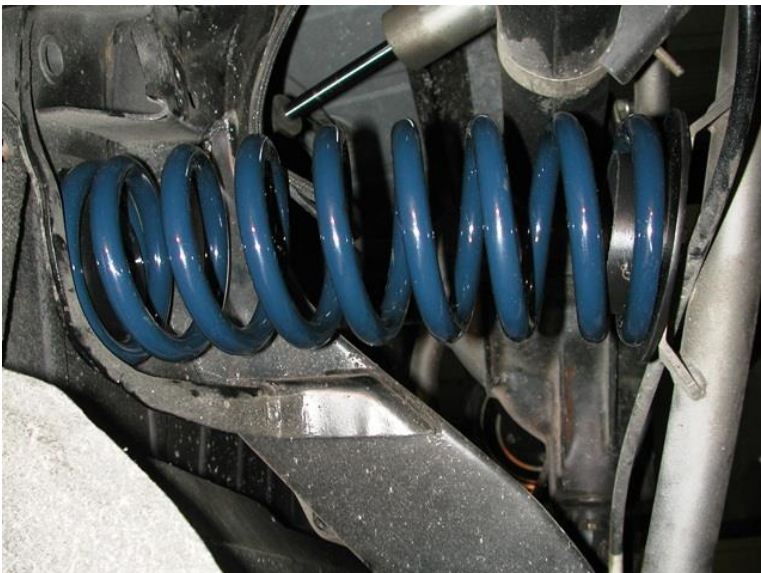

2. Support the axle, then remove the lower shock nut, and pull the shock off the stud. This will allow the axle to drop low enough to install the spring into the pockets.



### Part # 11059102 - 58-64 Chevy Fullsize Rear MuscleBar

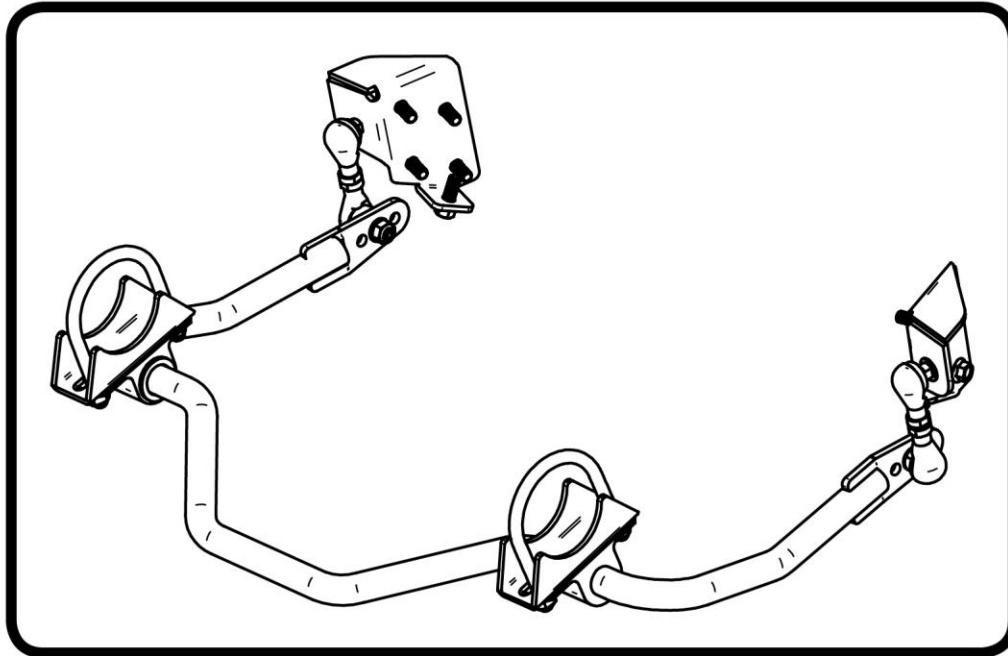

#### Recommended Tools



## 58-64 Chevy Fullsize MuscleBar Installation Instructions

#### Table of contents

- Page 2..... Included components and Hardware List
- Page 3..... Getting Started
- Page 4..... MuscleBar Installation
- Page 5..... MuscleBar Installation
- Page 6..... Final Tightening and Adjusting



### Major Components .....In the box

Item #	Part #	Description	QTY
1	90002444	58-64 Rear MuscleBar Assembly	1
2	90002445	Driver Frame Bracket	1
2	90002446	Passenger Frame Bracket	1
3	90000740	Axle Saddle Bracket	2
4	90000088	7/16" U bolt	2
5	99800004	Poly Bushing and Bracket	2
6	90000926	10mm 90 degree PosiLink end	4
	90001092	Tube of Lithium Grease (Not Shown)	

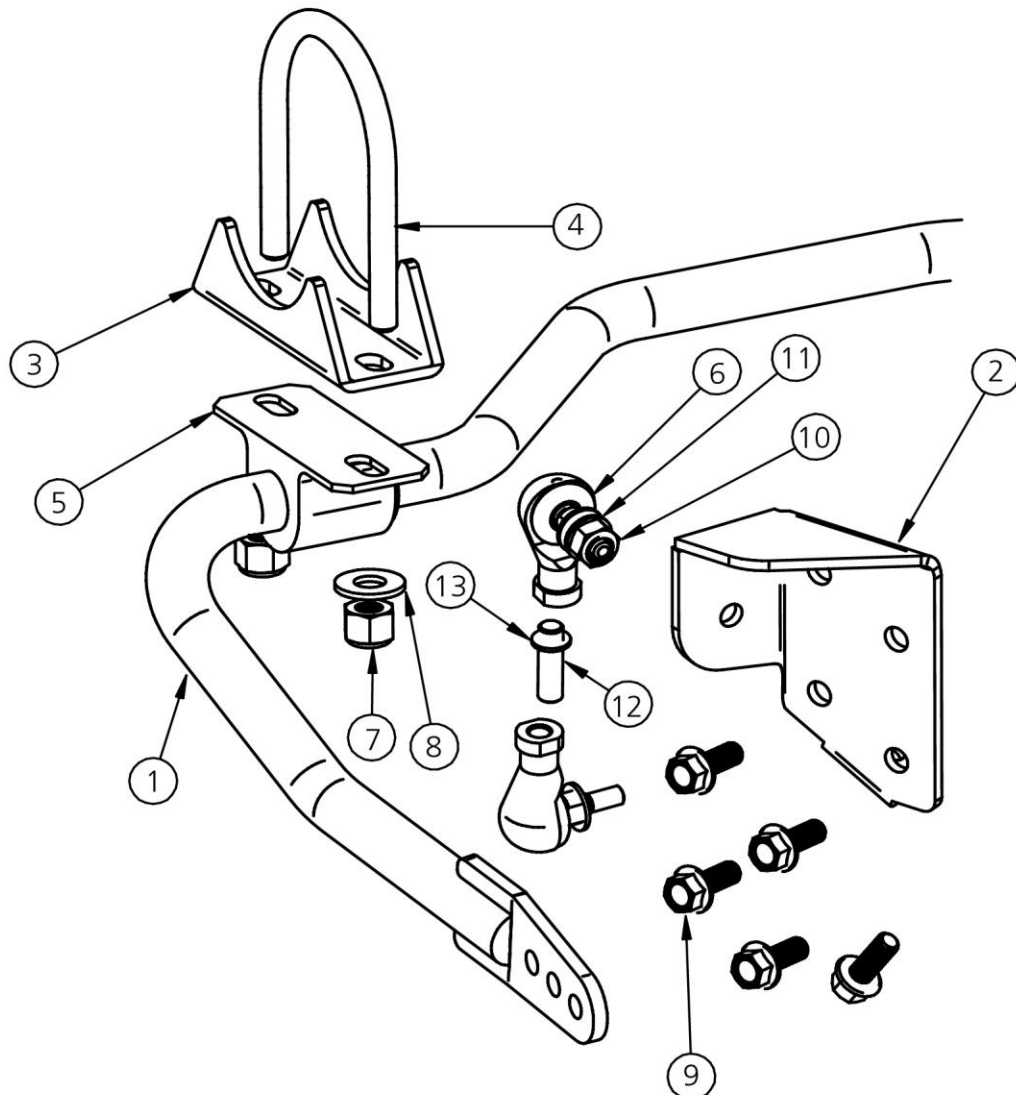



### Hardware List ....In the box

Item #	QTY	Part Number	Description	Location
7	4	99432001	7/16"-14 Nylok Nut	Axle Mount U-bolt
8	4	99433002	7/16" SAE Flatwasher	Axle Mount U-bolt
9	10	99373007	3/8"-16 x 1 Thread Forming Bolt	Frame Bracket to Frame
10	4	99112002	10mm-1.5 Nylok Nut	PosiLink to Bracket and MuscleBar
11	8	99373003	3/8" SAE FlatWasher	PosiLink to Bracket and MuscleBar
12	2	99115001	10mm-1.5 x 40mm Stud	Preassembled in Posilink Assembly
13	4	90002275	Aluminum Crush Washer	Preassembled in Posilink Assembly

### Getting Started.....

Congratulations on your purchase of the Ridetech Rear Muscle Bar. This system has been designed to give your car excellent handling along with a lifetime of enjoyment. One of the key features of this MuscleBar: Posilinks - The Posilink makes the reaction of the swaybar instantaneous, tuneability - this Musclebar has 3 positions to aid in the tuning of the handling of your car.

The MuscleBar has 3 positions to aid in the tuning of your car's handling. We start in the center position and tune from there. The position to the front of the car will make the Musclebar softer. The position to the rear of the car will make the MuscleBar stiffer.

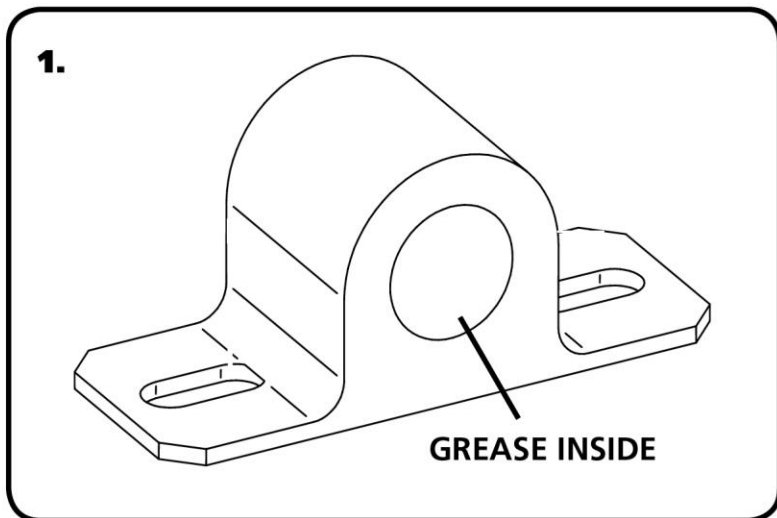

1. Apply Lithium grease to the inside of the sway bar bushings using the tube of grease supplied in the kit.



### MuscleBar Installation

2.

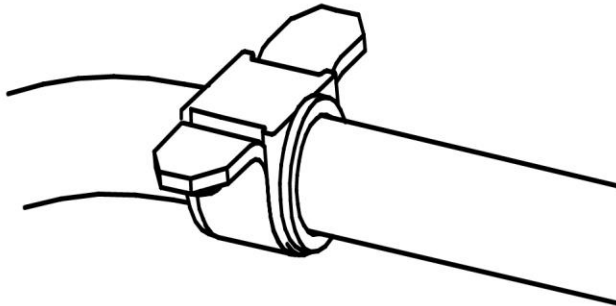

2. Install the swaybar bushings and straps onto the MuscleBar. The bushings and straps get installed on the outer ends of the MuscleBar against the stop rings.

3.

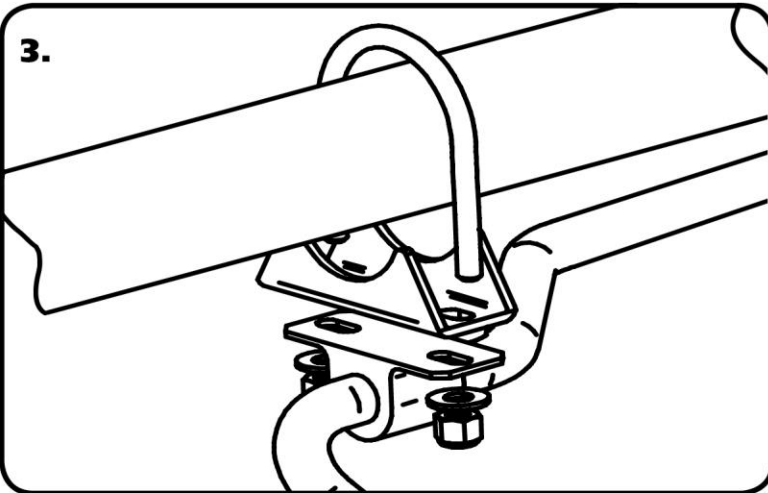

3. Install the U-bolts over the axle, slide the saddles onto the ubolts along with the MuscleBar. The MuscleBar should be centered on the rearend. Install the 7/16" washer and Nylok nut loosely for now. **DO NOT TIGHTEN NUTS YET.**

**Note:** It may be necessary to trim the panhard mount to get the saddle to sit in place properly on the axle tube. The saddle should be level with the ground.

**Note:** With the arms parallel with the ground the rear of the Muscle bar should be angle down towards the ground.

4a. DRIVERS BOTTOM VIEW

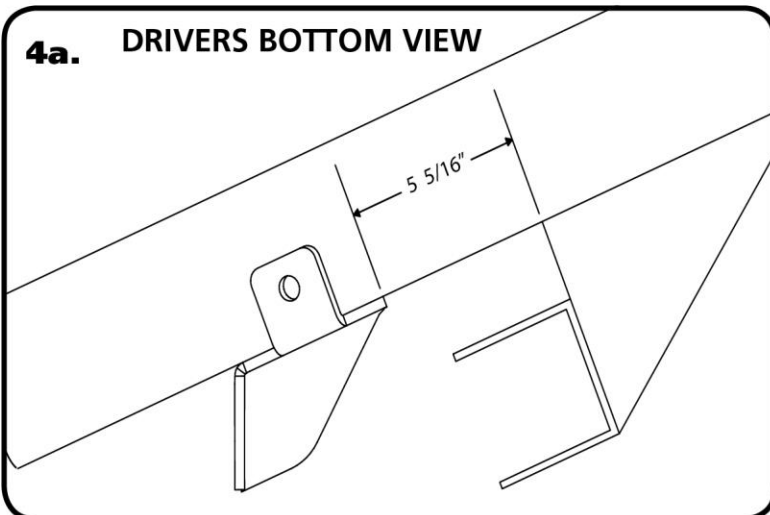

4a . There is a Driver and Passenger frame bracket. In illustrations 4a & 4b, the drivers side is shown. The bracket gets located by measuring from the lower control arm frame bracket. The frame bracket is located 5 5/16" (measuring towards the rear of the car) from the factory control arm bracket. This measurement is taken right where the factory bracket attaches to the frame.



### MuscleBar Installation

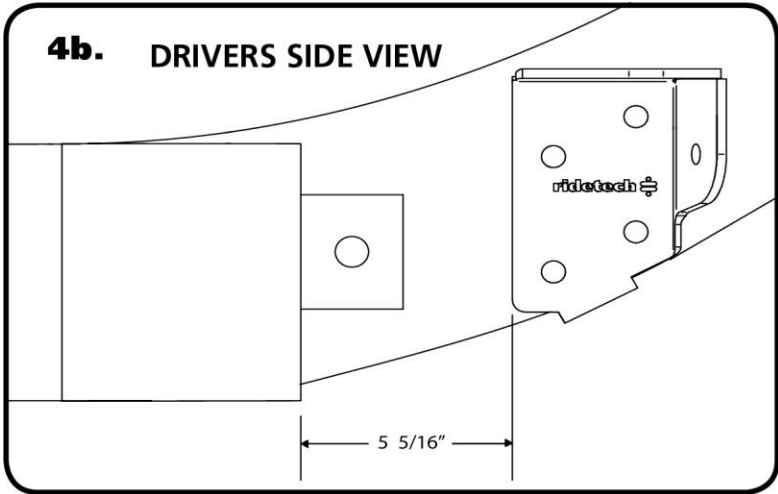

**4b.** This illustration shows the frame bracket as looking from the side. With the frame bracket held in place mark the (5) mounting holes. Drill these holes with a 5/16" drill bit. Attach each bracket with (5) 3/8-16" thread forming bolts.

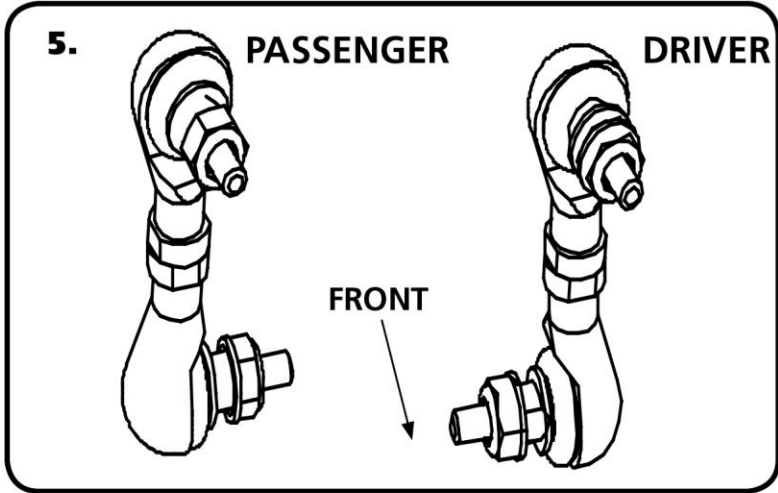

**5.** Install the PosiLinks in the frame brackets and in the CENTER hole in the MuscleBar using a 3/8" SAE Flatwasher on each side of the bracket and on each side of the mount on the MuscleBar. The Posilinks are installed with the stud on the upper Posilink pointing forward and the stud on the lower Posilink pointing to the inside of the car. Install the 10mm Nylok on Posilink and tighten nut.

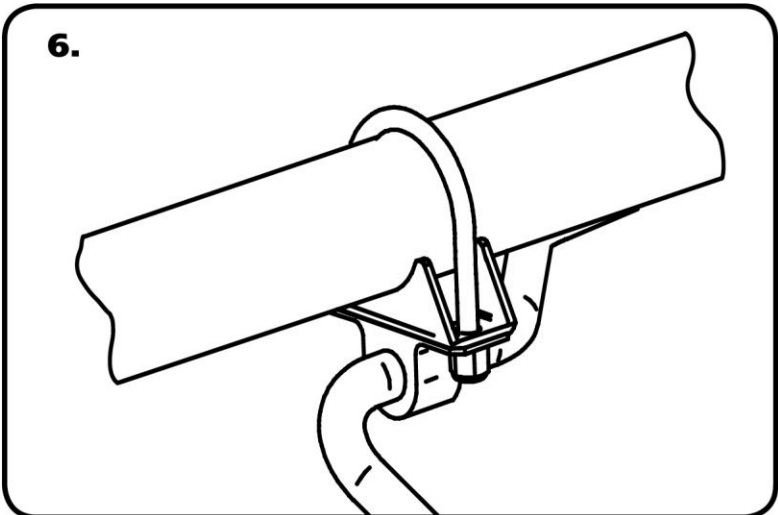

**6.** Tighten the 7/16" Nylok nuts on the U-bolts making sure the Musclebar is centered on the rearend.



### Final Tightening and Adjusting

5. The MuscleBar has (3) holes in the arms for adjustment. The center hole is the standard hole. You can stiffen the bar by moving the Posilnk in to the hole closest to the differential, or soften it by moving it to the hole at the end of the bar.

**Note:** If any grease is needed after installation use a lithium based grease. **DO NOT USE A PETROLEUM BASED GREASE**

**STILL HAVE QUESTIONS?**

**Tech line hours**

Monday - Friday

8AM - 6PM (EST) ..... 812-482-2932



## Ride Height

We have designed most cars to have a ride height of about 2" lower than factory. To achieve the best ride quality & handling, the shock absorber needs to be at 40-60% overall travel when the car is at ride height. This will ensure that the shock will not bottom out or top out over even the largest bumps. Measuring the shock can be difficult, especially on some front suspensions. Measuring overall wheel travel is just as effective and can be much easier. Most cars will have 4-6" of overall wheel travel. One easy way to determine where you are at in wheel travel is to take a measurement from the fender lip (center of the wheel) to the ground. Then lift the car by the frame until the wheel is just touching the ground, re-measure. This will indicate how far you are from full extension of the shock. A minimum of 1.5" of extension travel (at the wheel) is needed to ensure that the shock does not top out. If you are more than 3" from full extension of the shock then you are in danger of bottoming out the shock absorber.

## Adjusting Spring Height

When assembling the CoilOver, screw the spring retainer tight up to the spring (0 preload). After entire weight of car is on the wheels, jounce the suspension and roll the car forward and backward to alleviate suspension bind.

- If the car is too high w/ 0 preload then a smaller rate spring is required. Although threading the spring retainer down would lower the car, this could allow the spring to fall out of its seat when lifting the car by the frame.
- If the car is too low w/ 0 preload, then preload can then be added by threading the spring retainer up to achieve ride height. On 2.6" - 4" stroke shocks, up to 1.5" of preload is acceptable. On 5-7" stroke shocks, up to 2.5" of preload is acceptable. If more preload is needed to achieve ride height a stiffer spring rate is required. Too much preload may lead to coil bind, causing ride quality to suffer.

## Shock adjustment 101- Single Adjustable

### Rebound Adjustment:

How to adjust your new shocks.

The rebound adjustment knob is located on the top of the shock absorber protruding from the eyelet. You must first begin at the ZERO setting, then set the shock to a soft setting of 20.



-Begin with the shocks adjusted to the ZERO rebound position (full stiff). Do this by rotating the rebound adjuster knob clockwise until it stops.



-Now turn the rebound adjuster knob counter clock wise 20 clicks. This sets the shock at 20. (settings 21-24 are typically too soft for street use).

Take the vehicle for a test drive.



-if you are satisfied with the ride quality, do not do anything, you are set!



-if the ride quality is too soft increase the damping effect by rotating the rebound knob clock wise 3 clicks.

Take the vehicle for another test drive.



-if the vehicle is too soft increase the damping effect by rotating the rebound knob clock wise 3 additional clicks.



-If the vehicle is too stiff rotate the rebound adjustment knob counter clock wise 2 clicks and you are set!

Take the vehicle for another test drive and repeat the above steps until the ride quality is satisfactory.

Note:

One end of the vehicle will likely reach the desired setting before the other end. If this happens stop adjusting the satisfied end and keep adjusting the unsatisfied end until the overall ride quality is satisfactory.