

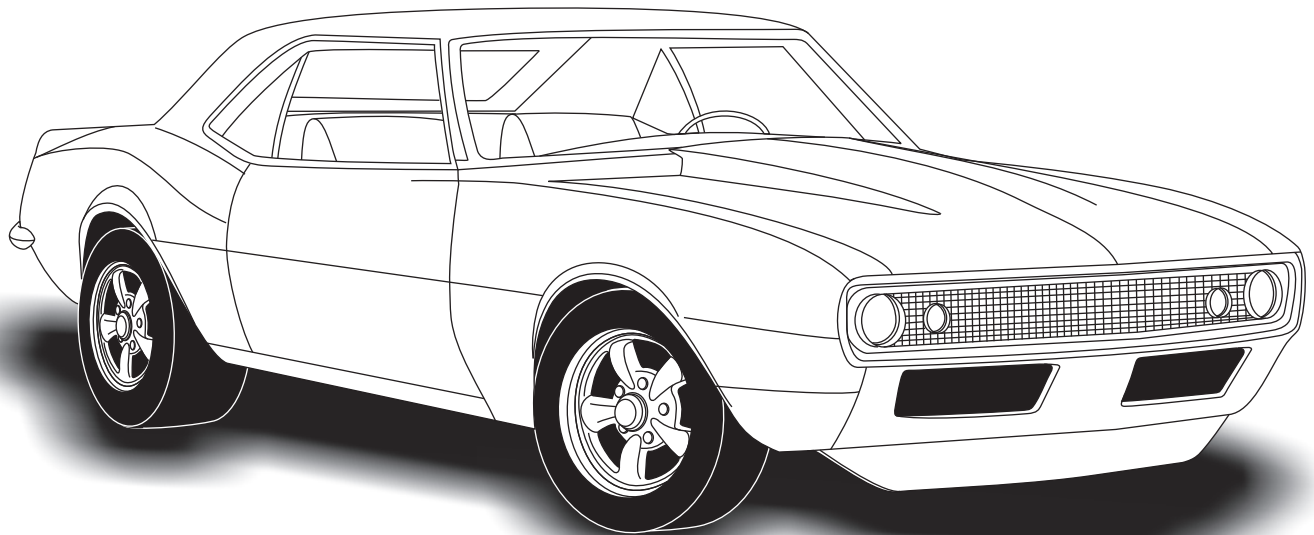

an ISO 9001:2015 Registered Company

1967-69 Chevrolet Camaro/ 1967-68 Pontiac Firebird

Condenser Kit *with* Drier
(021190)



18865 Goll St. San Antonio, TX 78266

Phone: 800-862-6658

Sales: sales@vintageair.com

Tech Support: tech@vintageair.com

www.vintageair.com



www.vintageair.com

Table of Contents

Cover..... 1

Table of Contents..... 2

Packing List/Parts Disclaimer..... 3

Information Page..... 4

Engine Compartment Disassembly..... 5

Drier Bracket Installation..... 6

Top Bracket Installation, Drier Installation..... 7

Hardline & Bottom Bracket Installation, Lubricating O-rings..... 8

Hood Latch Assembly, Condenser Installation..... 9

Condenser & Hardline Installation (Cont.).....10

Condenser & Hardline Installation (Final)..... 11

Hardline Support Bracket Installation..... 12

Packing List..... 13



A detailed tech video outlining the installation process is available on Vintage Air’s YouTube channel at <http://bit.ly/2LVX1pX>.

Viewing the tech video along with the written instructions will provide the installer the most detailed installation procedure.



www.vintageair.com

Packing List: Condenser Kit (021190)

No.	Qty.	Part No.	Description
1.	1	03766-VUC	Condenser, 14" x 22" Parallel Flow
2.	1	07321-VUC	Drier
3.	1	18148-VUB	Nut, 5/16"
4.	1	18152-VUB	Nut with Star Washer, 1/4-20
5.	10	18249-VUB	Screw, 10-24 x 3/8", Pan Head
6.	10	18260-VUB	Nut with Star Washer, 10-24
7.	1	18610-VUB	Lock Washer, 5/16"
8.	2	18611-VUB	Washer, 5/16" Flat
9.	1	18310-VUB	Bolt, 5/16-18 x 1 1/2"
10.	2	18977-VUB	U-nut, 5/16"
11.	3	33857-VUF	O-ring, #6
12.	1	33858-VUF	O-ring, #8
13.	1	35367-VCG	Hardline, #8 Condenser/Core
14.	1	35368-VCG	Hardline, #6 Condenser/Drier
15.	1	640685	Bracket, Hardline Support
16.	1	64268-VCB	Bracket, Condenser, Top
17.	1	64368-VCB	Bracket, Condenser, Bottom Right
18.	1	64468-VCB	Bracket, Condenser, Bottom Left
19.	1	659981	Bracket, Drier
20.	1	090173	Hardline, #6 Drier/Fenderwell
21.	1	11079-VUS	Binary Switch, Male
22.	1	23127-VUW	Compressor Lead
23.	1	186011	Washer, .625" OD X .281" ID
24.	1	18258-VUB	Screw, 10-32 x 3/4", Pan Head
25.	1	31603-VUD	Adel Clamp, #4
26.	1	31600-VUD	Adel Clamp, #2
27.	1	18251-VUB	Nut with Star Washer, 10-32

**** Before beginning installation, open all packages and check contents of shipment. Please report any shortages directly to Vintage Air within 15 days. After 15 days, Vintage Air will not be responsible for missing or damaged items.**

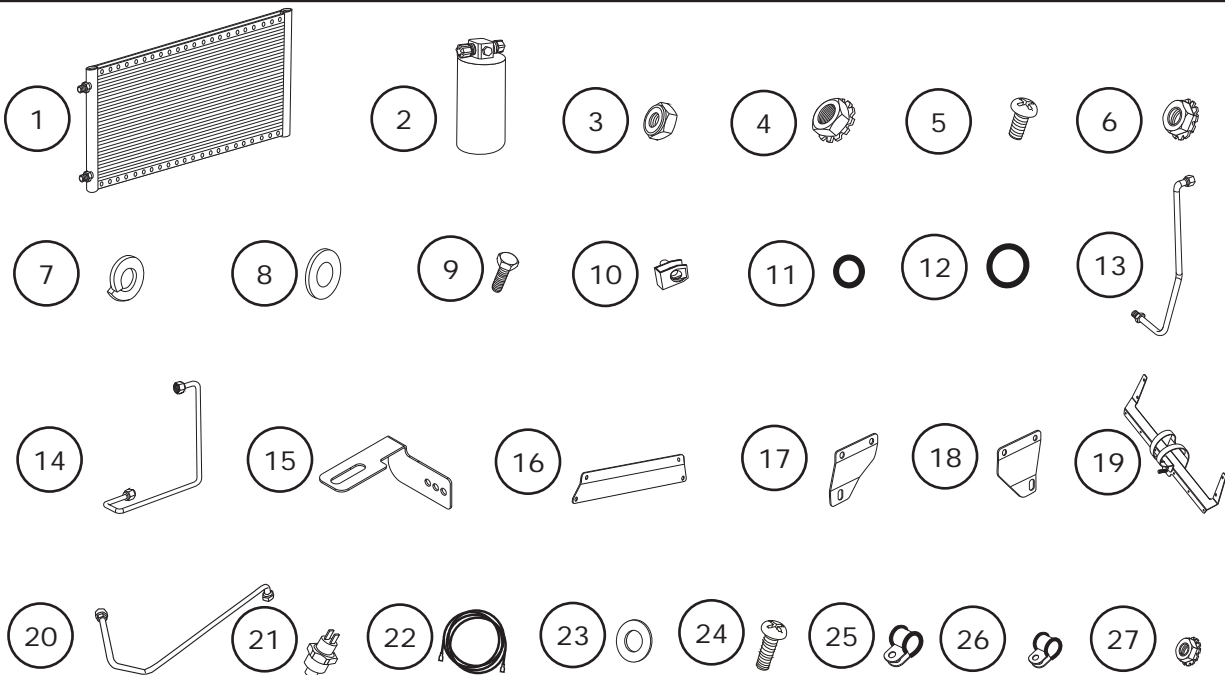

NOTE: Images may not depict actual parts and quantities. Refer to packing list for actual parts and quantities.



www.vintageair.com

Important Notice—Please Read

For Maximum System Performance, Vintage Air Recommends the Following:

NOTE: Vintage Air systems are designed to operate with R134a refrigerant only. Use of any other refrigerant could damage your A/C system and/or vehicle, and possibly cause a fire, in addition to potentially voiding the warranties of the A/C system and its components.

Refrigerant Capacities:

Vintage Air System: 1.8 lbs. (28.8 oz.) or 816 grams of **R134a**, charged by weight with a quality charging station or scale. **NOTE: Use of the proper type and amount of refrigerant is critical to system operation and performance.**

Other Systems: Consult manufacturer's guidelines.

Lubricant Capacities:

New Vintage Air-supplied Sanden Compressor: No additional oil needed (Compressor is shipped with proper oil charge).

All Other Compressors: Consult manufacturer (Some compressors are shipped dry and will need oil added).

Safety Switches

Your Vintage Air system is equipped with a binary pressure safety switch. A binary switch disengages the compressor clutch in cases of extreme low pressure conditions (Refrigerant Loss) or excessively high head pressure (406 PSI) to prevent compressor damage or hose rupture. A trinary switch combines Hi/Lo pressure protection with an electric fan operation signal at 254 PSI, and should be substituted for use with electric fans. Compressor safety switches are extremely important since an A/C system relies on refrigerant to circulate lubricant.

Service Info:

Protect Your Investment: Prior to assembly, it is critical that the compressor, evaporator, A/C hoses and fittings, hardlines, condenser and receiver/drier remained capped. Removing caps prior to assembly will allow moisture, insects and debris into the components, possibly leading to reduced performance and/or premature failure of your A/C system. This is especially important with the receiver/drier.

Additionally, when caps are removed for assembly, **BE CAREFUL!** Some components are shipped under pressure with dry nitrogen.

Evacuate the System for 35-45 Minutes: Ensure that system components (Drier, compressor, evaporator and condenser) are at a temperature of at least 85° F. On a cool day, the components can be heated with a heat gun **or** by running the engine with the heater on before evacuating. Leak check and charge to specifications.

Bolts Passing Through Cowl and/or Firewall:

To ensure a watertight seal between the passenger compartment and the vehicle exterior, for all bolts passing through the cowl and/or firewall, Vintage Air recommends coating the threads with silicone prior to installation.

Heater Hose (Not Included With This Kit):

Heater hose may be purchased from Vintage Air (Part# 31800-VUD) or your local parts retailer. Routing and required length will vary based on installer preference.



www.vintageair.com

Engine Compartment Disassembly

NOTE: Before starting the installation, check the function of the vehicle (horn, lights, etc.) for proper operation, and study the instructions, illustrations, & diagrams.

Perform the Following:

1. Evacuate the A/C system if necessary.
2. Remove the hood latch by removing (5) bolts (retain), then remove the hood latch support assembly (retain) (See Photos 1 & 3, below).
3. Disconnect and remove the A/C hoses from the OEM condenser and drier (discard) (See Photos 2 & 4, below).
4. Remove the OEM condenser (discard) by removing (4) OEM mounting bolts (discard) (See Photo 3, below).
5. Remove the OEM drier (discard) (See Photo 4, below).

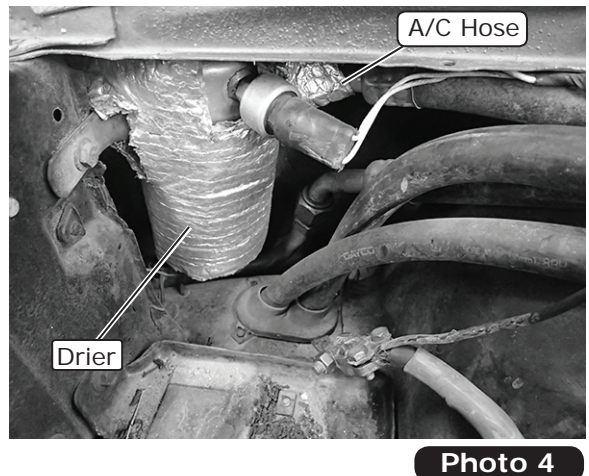
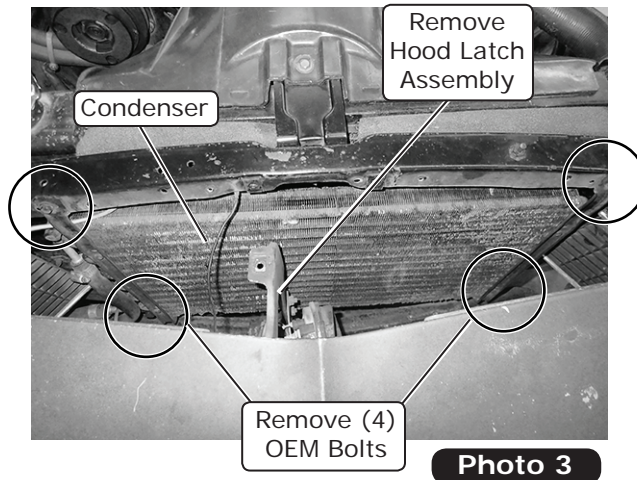
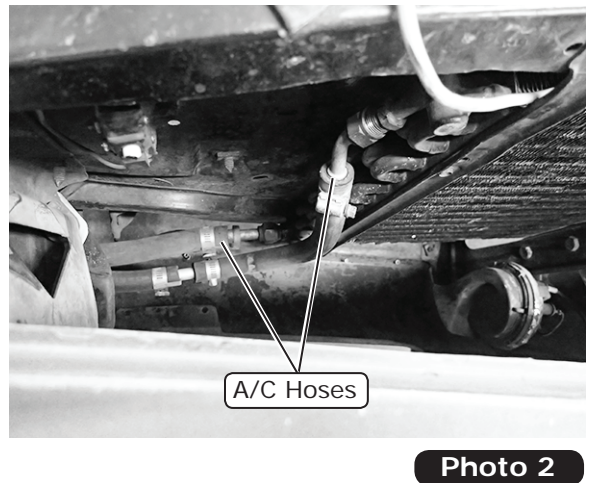
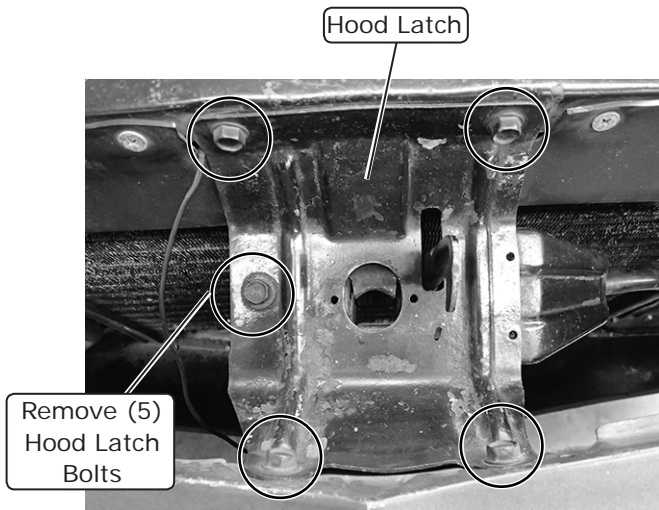



www.vintageair.com

Drier Bracket Installation

1. On a workbench, install the drier mounting bracket onto the front of the condenser using (4) 10-24 x 3/8" pan head screws and (4) 10-24 nuts with star washers (See Figures 1 & 1a, below). **NOTE: The bracket mounts through the 1st and 3rd holes from the left side of the condenser.**

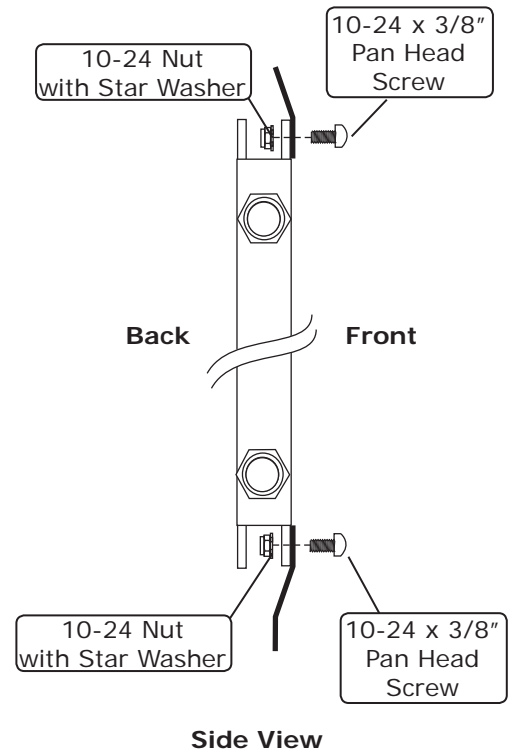
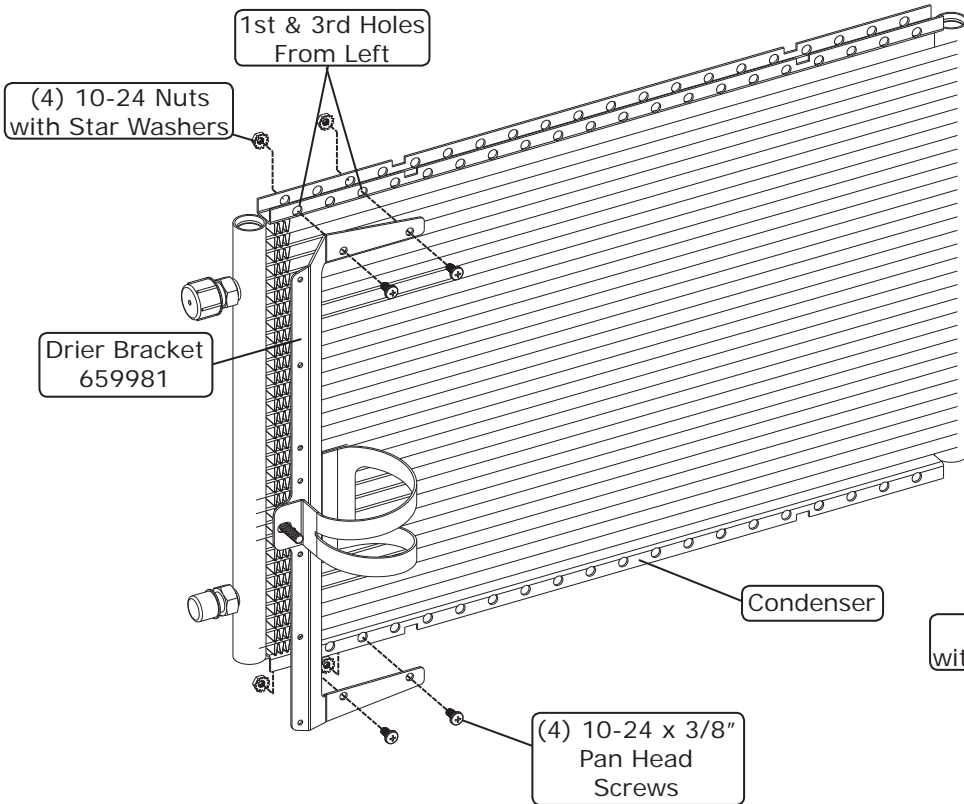



www.vintageair.com

Top Bracket Installation

1. Install (2) 5/16" U-nuts onto the top condenser mounting bracket as shown in Figures 2 & 2a, below.
2. Install the top mounting bracket onto the front of the condenser using (2) 10-24 x 3/8" pan head screws and (2) 10-24 nuts with star washers (See Figures 2 & 2a, below). **NOTE: The bracket mounts to the outside of the flange through the 6th and 14th holes from the left side of the condenser.**

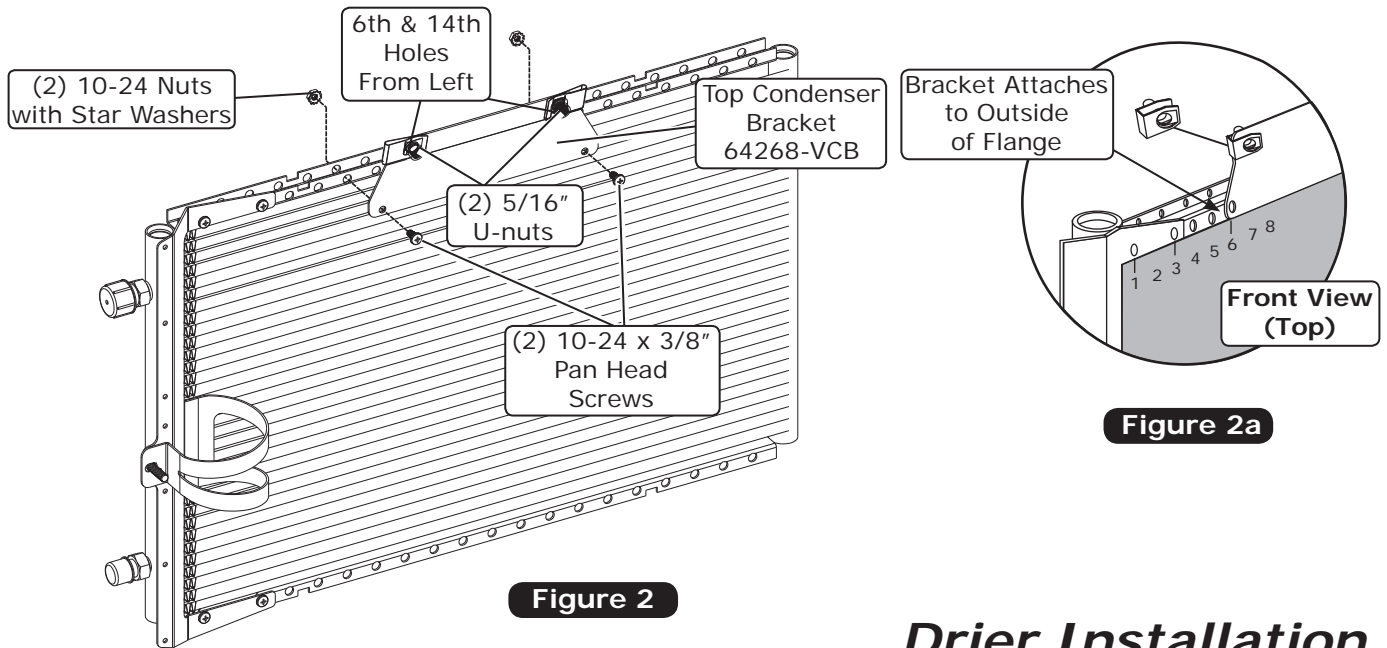

Figure 2a

Figure 2

Drier Installation

NOTE: Do not remove the caps from the drier. The drier contains a desiccant that will quickly absorb moisture from the air, causing it to lose effectiveness. For this reason, Vintage Air recommends that the drier remains capped until the installer is ready to evacuate the system.

Perform the Following:

1. Insert the drier into the drier bracket (See Figure 3, below).
2. Loosely secure the drier into the drier bracket using a 1/4-20 star nut with washer as shown in Figure 3, below. **NOTE: Do not fully tighten the nut at this time. Refrigerant flow through the drier is IN from condenser, OUT to evaporator.**

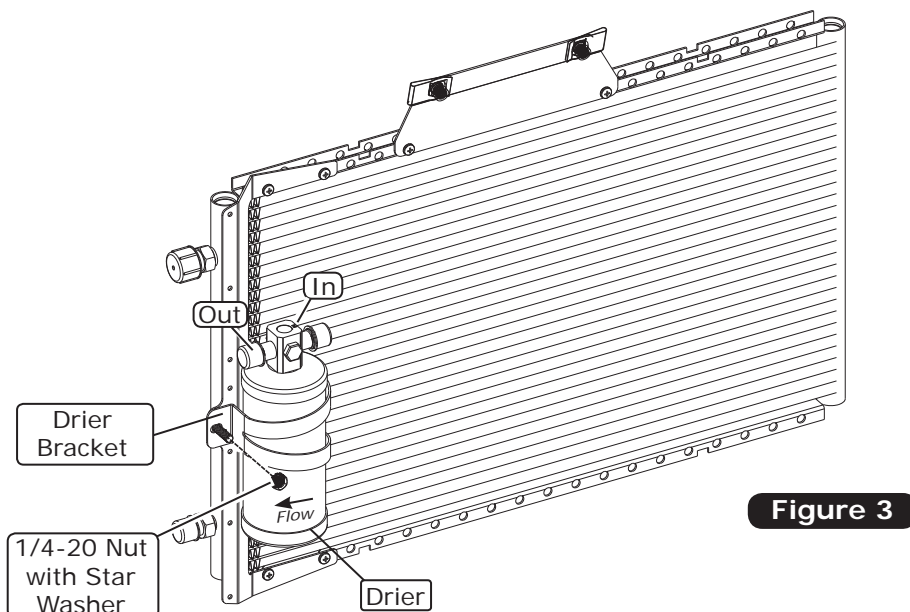

Figure 3



www.vintageair.com

Hardline & Bottom Bracket Installation

1. Lubricate (2) #6 O-rings, and install the #6 condenser/drier hardline as shown in Figures 4 & 5, below. Tighten the fittings as shown in Figure 5, below. **NOTE: Tighten the drier bracket nut at this time.**
2. Using (4) 10-24 x 3/8" pan head screws and (4) 10-24 nuts with star washers, install the (2) bottom condenser mounting brackets onto the front of the condenser as shown in Figures 4 & 4a, below. **NOTE: The brackets mount to the outside of the flange. The left bracket mounts through the 5th and 7th holes from the left side of the condenser. The right bracket mounts through the 12th and 14th holes from the left side of the condenser.**

Figure 4

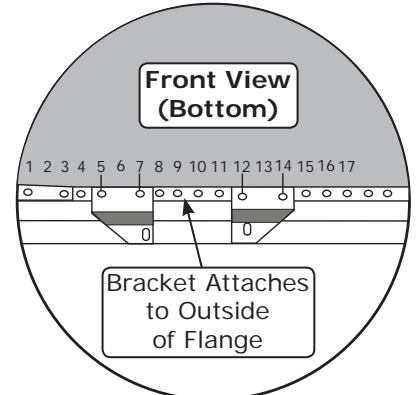
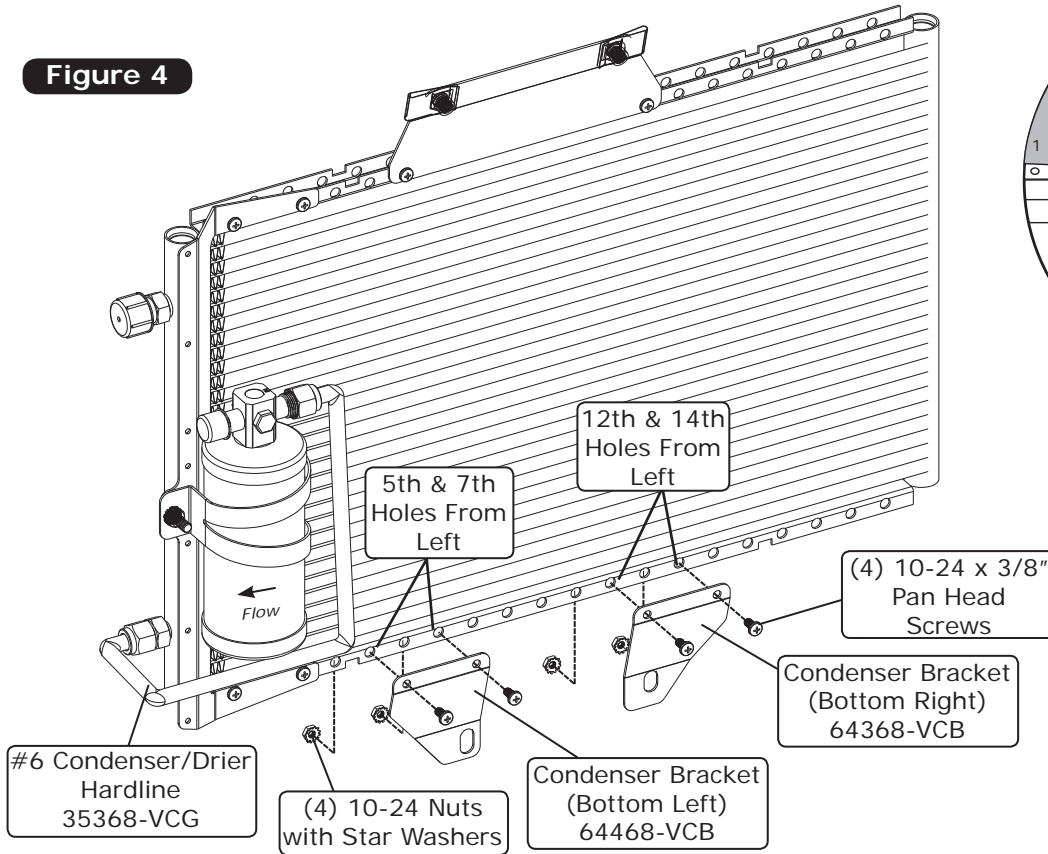
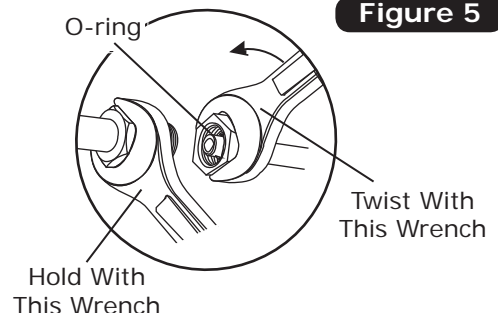
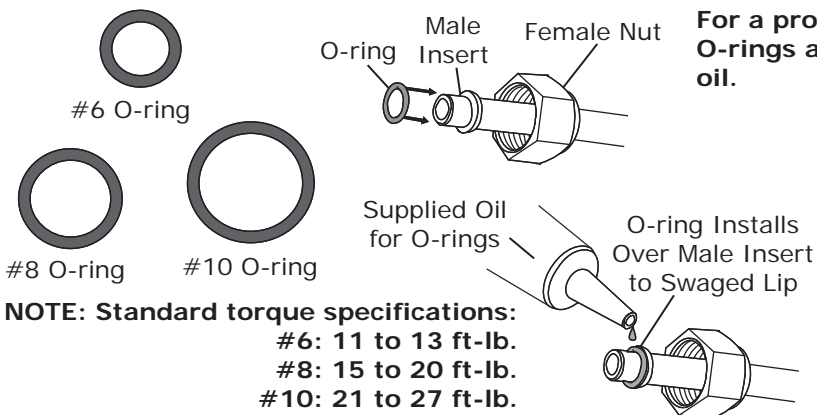

Figure 4a

Lubricating O-rings

For a proper seal of fittings: Install supplied O-rings as shown, and lubricate with supplied oil.

Figure 5





www.vintageair.com

Condenser Installation

1. Lower the condenser/hardline assembly between the front side of the core support and the front header panel (See Figures 6 & 7, below). **NOTE: The top mounting bracket attaches to the engine side of the core support. The bottom brackets attach to the front of the core support.**
2. Secure the bottom driver side of the condenser to the core support using a 5/16-18 x 1 1/2" hex bolt, a flat washer, a lock washer, and a 5/16" hex nut as shown in Figure 7, below.
3. Secure the bottom passenger side of the condenser to the core support using an OEM bolt (See Figure 7, below).

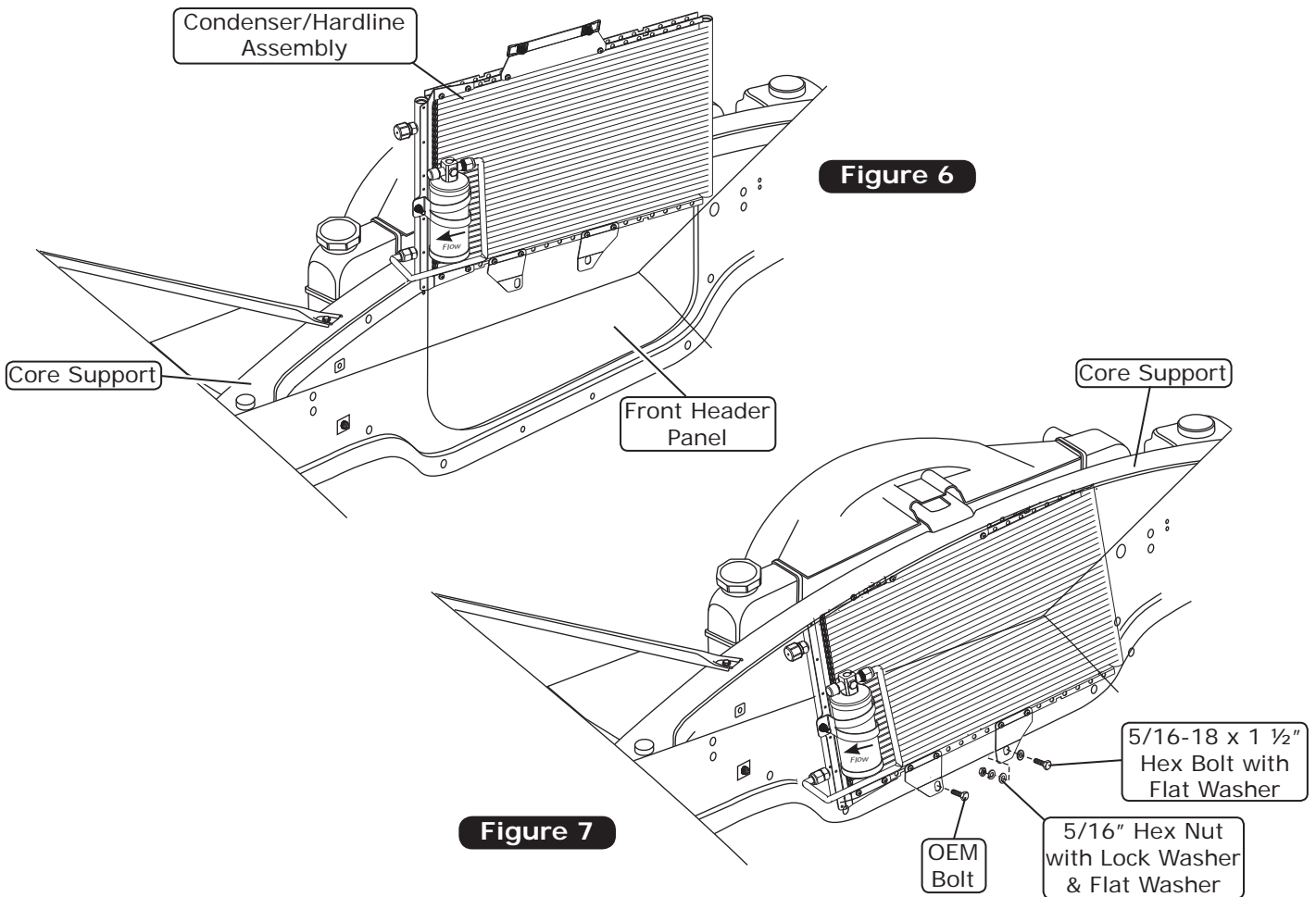



www.vintageair.com

Condenser & Hardline Installation (Cont.)

1. Reinstall the hood latch assembly using the OEM bolts. Install the OEM bolts through the hood latch assembly, through the core support, and into the U-nuts on the top condenser bracket (See Figure 8, below).
2. Lubricate a #6 O-ring, and install the #6 drier/fenderwell hardline as shown in Figure 5, Page 8, and Figure 9, below. Tighten the fittings as shown in Figure 5, Page 8.

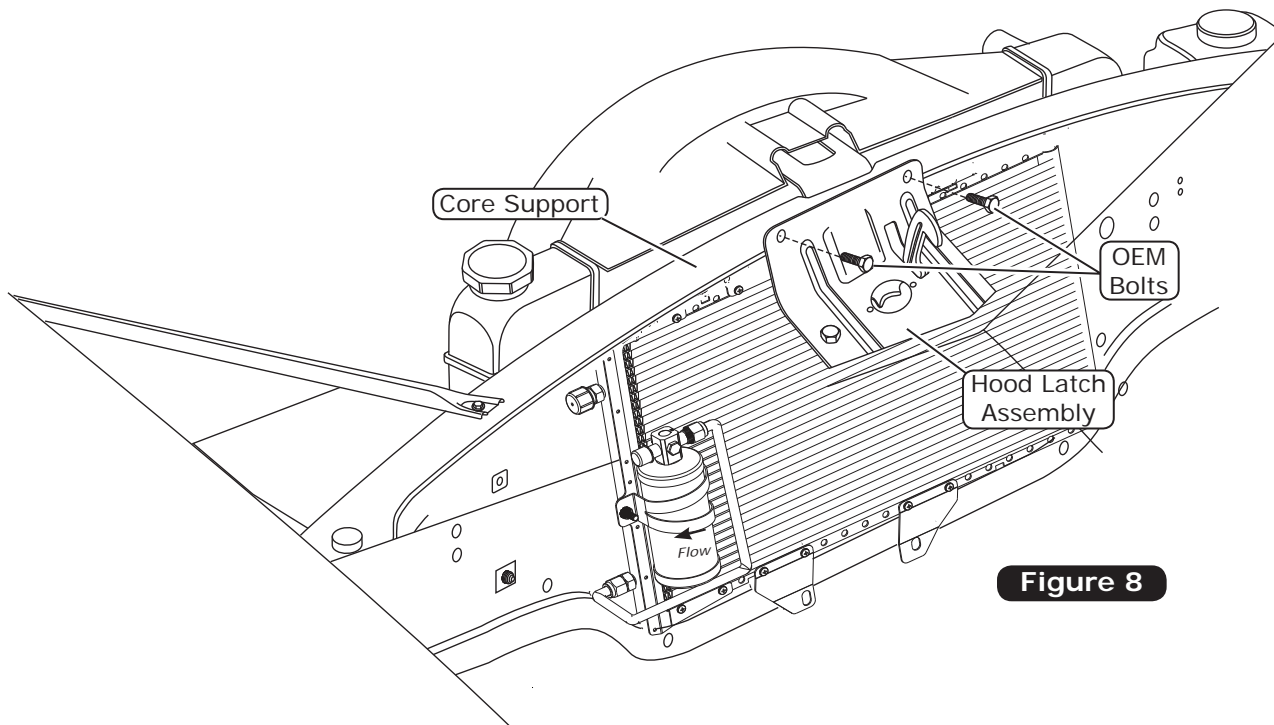

Figure 8

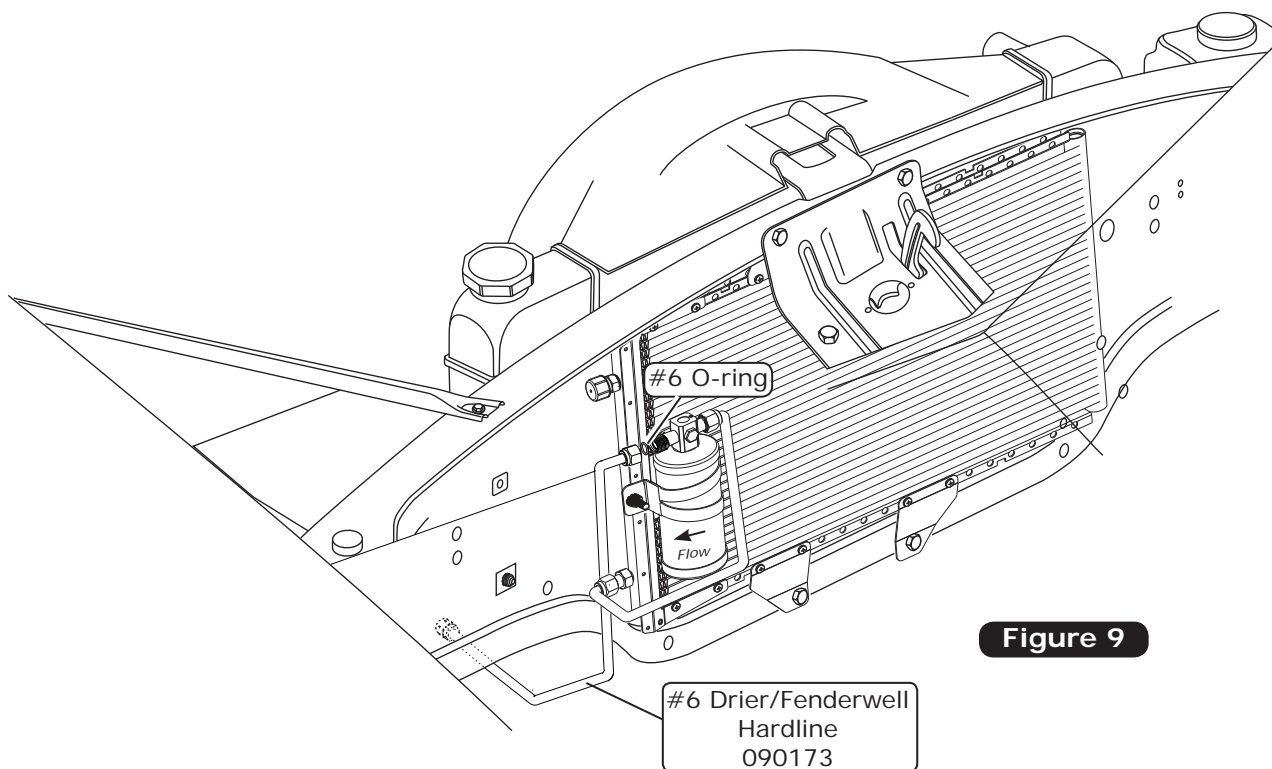

Figure 9



www.vintageair.com

Condenser & Hardline Installation (Final)

1. Lubricate a #8 O-ring, and install the #8 condenser/core hardline as shown in Figure 5, Page 8, and Figure 10, below. Tighten the fittings as shown in Figure 5, Page 8.
2. Install the binary switch onto the drier as shown in Figure 11, below.

Figure 10

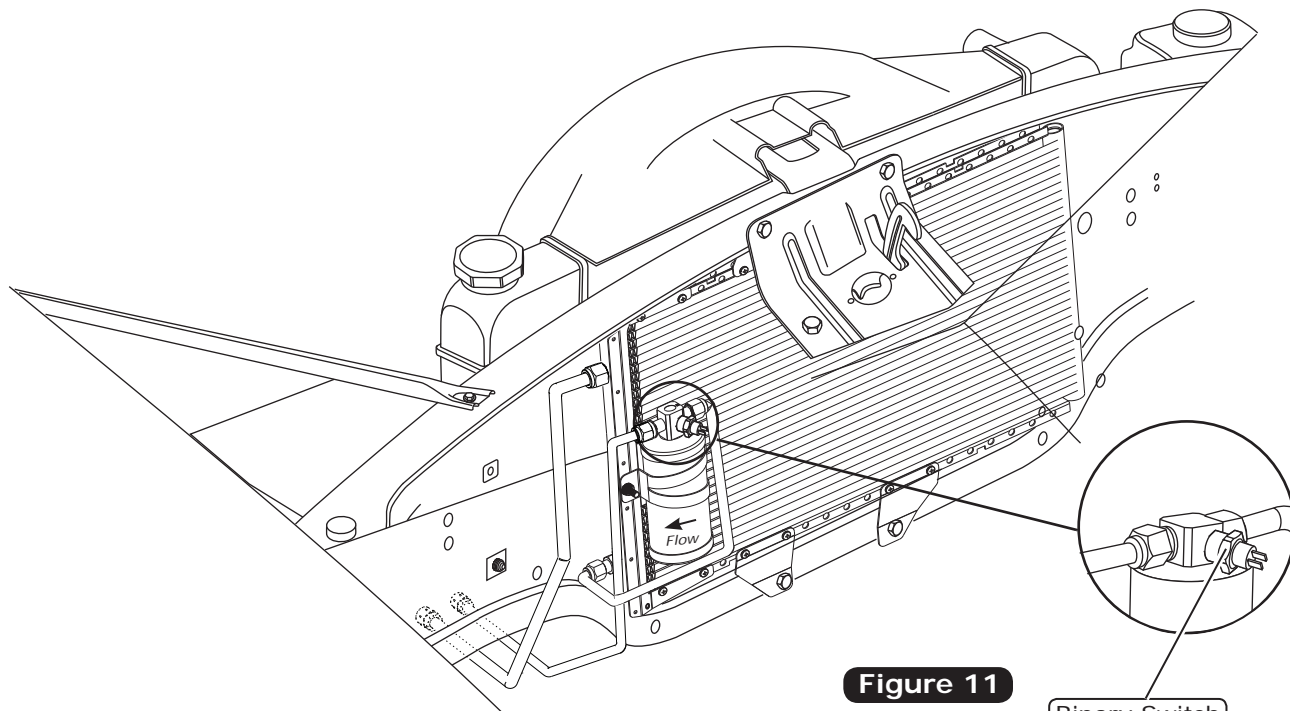
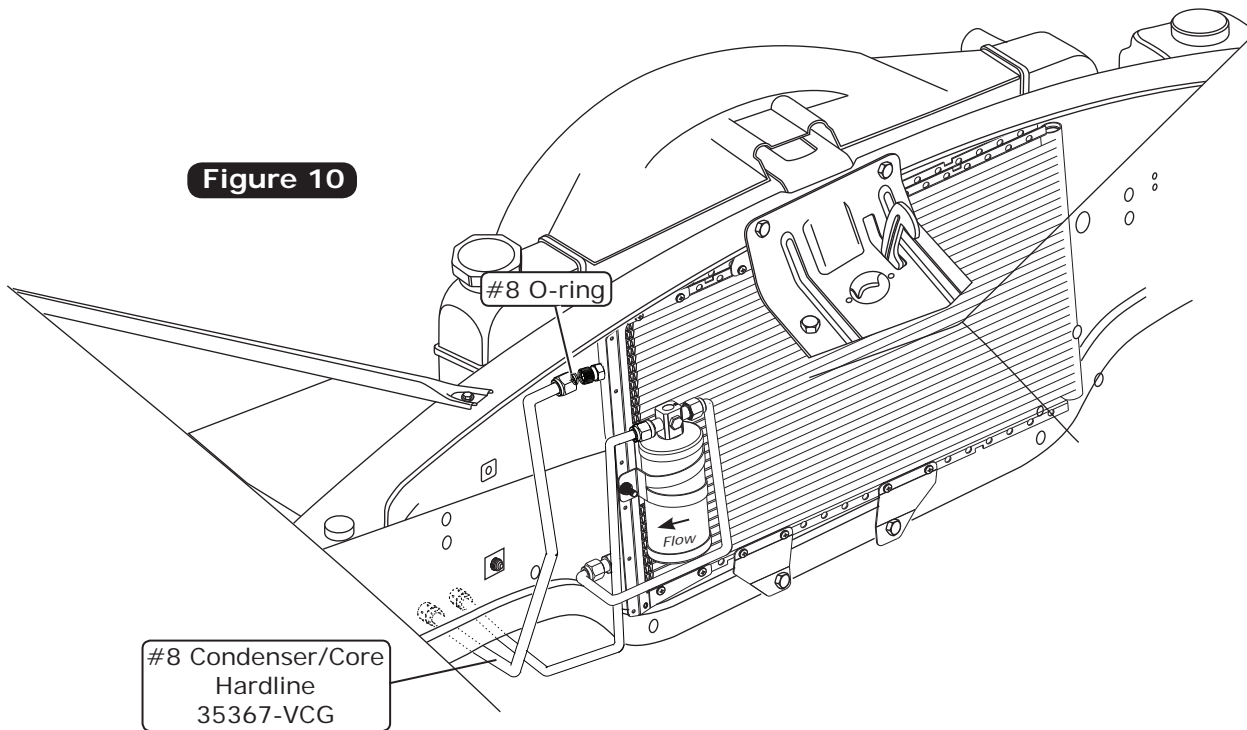

Figure 11



www.vintageair.com

Hardline Support Bracket Installation

1. Install a #4 Adel clamp onto the #8 condenser/core hardline, and a #2 Adel clamp onto the #6 drier/fenderwell hardline (See Photos 1 & 2, below).
2. Install the hardline support bracket onto the core support using the OEM radiator bolt (See Photo 3, below).
NOTE: Do not fully tighten at this time.
3. Using a 10-32 x 3/4" pan head screw and a 10-32 nut with star washer, secure both Adel clamps onto the hardline support bracket (See Photos 4 & 5, below). **NOTE: Tighten the OEM radiator bolt at this time. This concludes the condenser kit portion of your installation.**

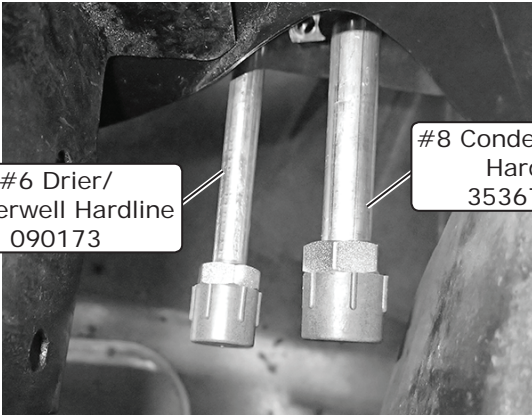

#6 Drier/
Fenderwell Hardline
090173

#8 Condenser/Core
Hardline
35367-VCG

Photo 1

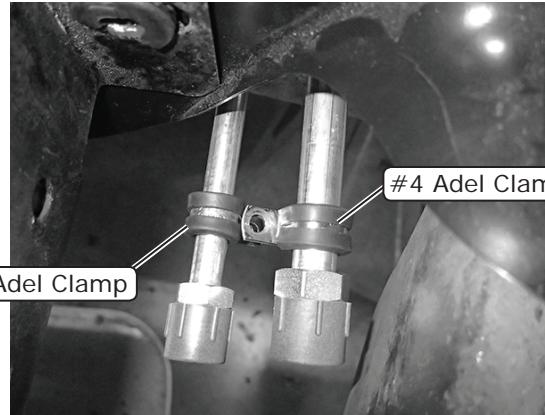

#4 Adel Clamp

#2 Adel Clamp

Photo 2

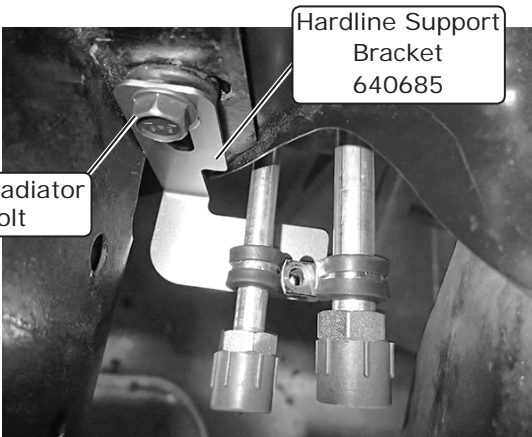

Hardline Support
Bracket
640685

OEM Radiator
Bolt

Photo 3

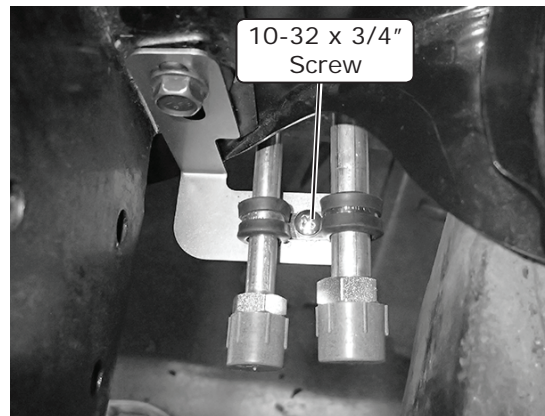

10-32 x 3/4"
Screw

Photo 4

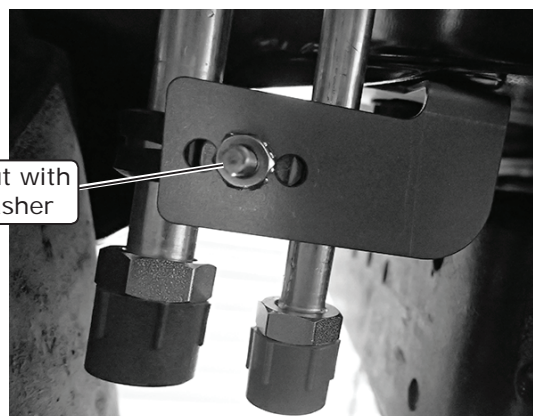

10-32 Nut with
Star Washer

Photo 5



www.vintageair.com

Packing List: Condenser Kit (021190)

No.	Qty.	Part No.	Description
1.	1	03766-VUC	Condenser, 14" x 22" Parallel Flow
2.	1	07321-VUC	Drier
3.	1	18148-VUB	Nut, 5/16"
4.	1	18152-VUB	Nut with Star Washer, 1/4-20
5.	10	18249-VUB	Screw, 10-24 x 3/8", Pan Head
6.	10	18260-VUB	Nut with Star Washer, 10-24
7.	1	18610-VUB	Lock Washer, 5/16"
8.	2	18611-VUB	Washer, 5/16" Flat
9.	1	18310-VUB	Bolt, 5/16-18 x 1 1/2"
10.	2	18977-VUB	U-nut, 5/16"
11.	3	33857-VUF	O-ring, #6
12.	1	33858-VUF	O-ring, #8
13.	1	35367-VCG	Hardline, #8 Condenser/Core
14.	1	35368-VCG	Hardline, #6 Condenser/Drier
15.	1	640685	Bracket, Hardline Support
16.	1	64268-VCB	Bracket, Condenser, Top
17.	1	64368-VCB	Bracket, Condenser, Bottom Right
18.	1	64468-VCB	Bracket, Condenser, Bottom Left
19.	1	659981	Bracket, Drier
20.	1	090173	Hardline, #6 Drier/Fenderwell
21.	1	11079-VUS	Binary Switch, Male
22.	1	23127-VUW	Compressor Lead
23.	1	186011	Washer, .625" OD X .281" ID
24.	1	18258-VUB	Screw, 10-32 x 3/4", Pan Head
25.	1	31603-VUD	Adel Clamp, #4
26.	1	31600-VUD	Adel Clamp, #2
27.	1	18251-VUB	Nut with Star Washer, 10-32

Checked By: _____
Packed By: _____
Date: _____

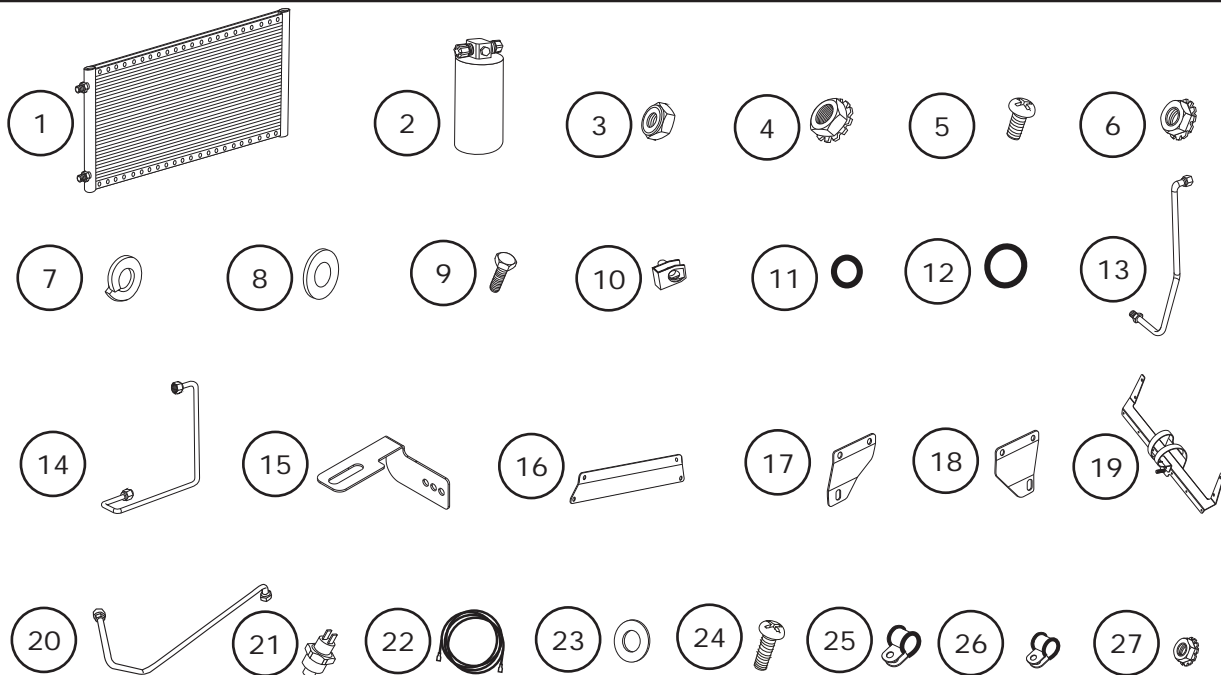

**NOTE: Images may not depict actual parts and quantities.
Refer to packing list for actual parts and quantities.**