



1955-56 CHEVY CONDENSER w/ DRIER (6 CYL POSITION)

CONDENSER KIT PACKING LIST

CONDENSER KIT
03357-VCC-A

No.	QTY.	PART No.	DESCRIPTION
1.	1	03768-VUC	17" x 19" PARALLEL FLOW CONDENSER
2.	1	64821-VCB	PASSENGER SIDE CONDENSER BRACKET
3.	1	64822-VCB	DRIVER SIDE CONDENSER BRACKET
4.	1	35015-VCG	#6 ALUMINUM HARDLINE COND TO DRIER
5.	1	35016-VCG	#8 ALUMINUM HARDLINE COND TO CORE SUPPORT
6.	1	07321-VUC	STANDARD DRIER
7.	1	65980-VCB	STANDARD DRIER BRACKET
8.	8	18233-VUB	#6 x 3/8" PAN HEAD SCREWS
9.	1	18290-VUB	1/4" x 1" BOLT
10.	1	18136-VUB	1/4" NUT
11.	1	18125-VUB	1/4" FLAT WASHER
12.	2	33857-VUF	#6 O-RING
13.	1	33858-VUF	#8 O-RING
14.	1	33134-VUI	2-HOLE GROMMET

CHECKED BY: _____
 PACKED BY: _____
 DATE: _____

NOTE: REFRIGERANT FLOW THROUGH DRIER IS IN FROM CONDENSER, OUT TO EVAPORATOR.

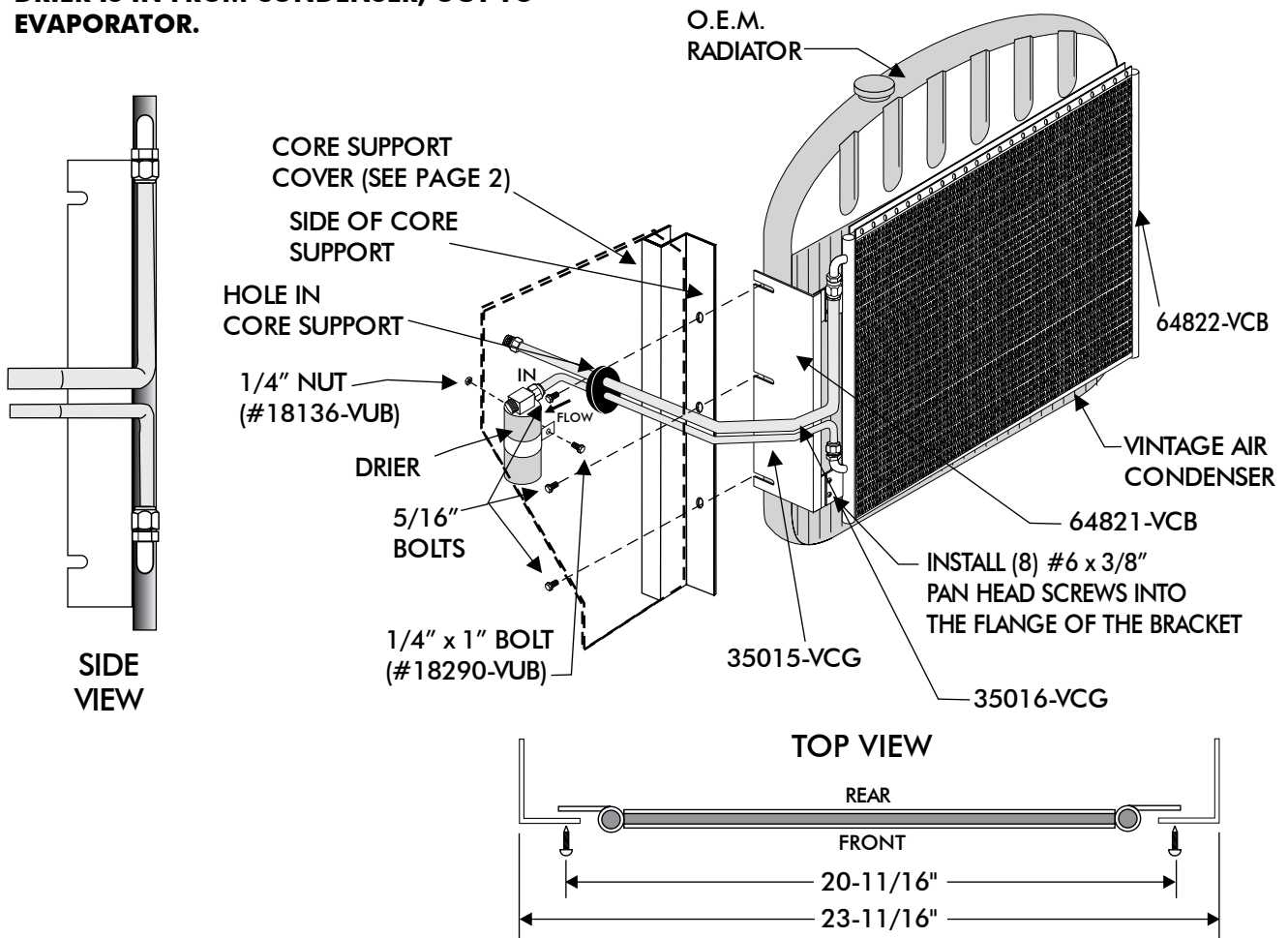

(TOP)
**CORE SUPPORT
MODIFICATION**

