

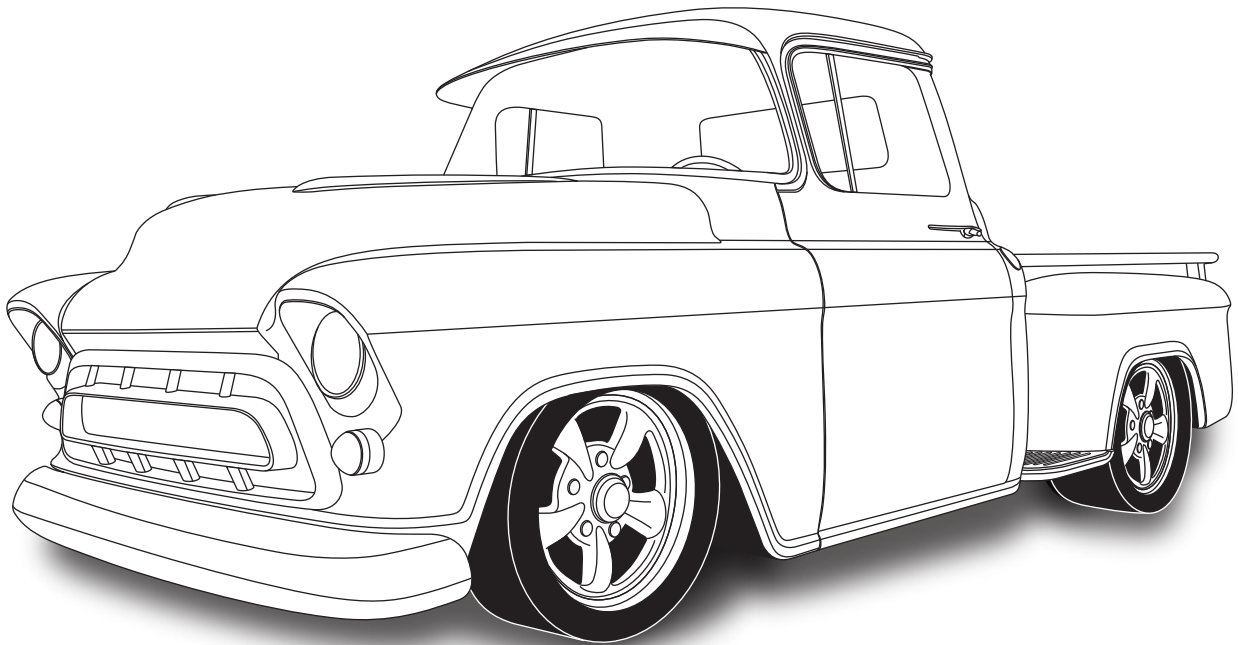

an ISO 9001:2008 Registered Company

1958-59 Chevy Pickup

Condenser with Drier
021558



18865 Goll St. San Antonio, TX 78266 ph: 210-654-7171 fax: 210-654-3113



Table of Contents

- 1. Cover**
- 2. Table of Contents**
- 3. Packing List/Parts Disclaimer**
- 4. Engine Compartment & Core Support Modification**
- 5. Condenser Mounting Bracket Installation & Drier Bracket Installation**
- 6. Drier Installation & Hardline Installation**
Figure 1
- 7. Condenser Installation & Hardline Installation**
- 8. Packing List**



Packing List: 1958-59 Chevy Pickup Condenser Kit With Drier (021558)

No.	Qty.	Part No.	Description
1.	1	03768-VUC	17" X 19" Super Flow Cond
2.	2	07113-VUB	Drier Clamp
3.	1	07321-VUC	Drier
4.	2	18247-VUB	#10 X 1/2" Hex Screw
5.	12	18249-VUB	10-24 X 3/8" Pan Head Screw
6.	12	18260-VUB	10-24 Nut w/ Star Washer
7.	1	33134-VUI	2-hole Grommet
8.	3	33857-VUF	#6 O-ring
9.	1	33858-VUF	#8 O-ring
10.	1	095016	Hardline 58-59 Chevy Pickup #6 Cond/Drier
11.	1	095018	Hardline 58-59 Chevy Pickup #6 Drier/Core
12.	1	095017	Hardline 58-59 Chevy Pickup #8 Cond/Comp
13.	2	644091	Brkt 58-66 Chevy Pickup Cond
14.	1	644090	Brkt 58-66 Chevy Pickup Drier

**** Before beginning installation, open all packages and check contents of shipment. Please report any shortages directly to Vintage Air within 15 days. After 15 days, Vintage Air will not be responsible for missing or damaged items.**

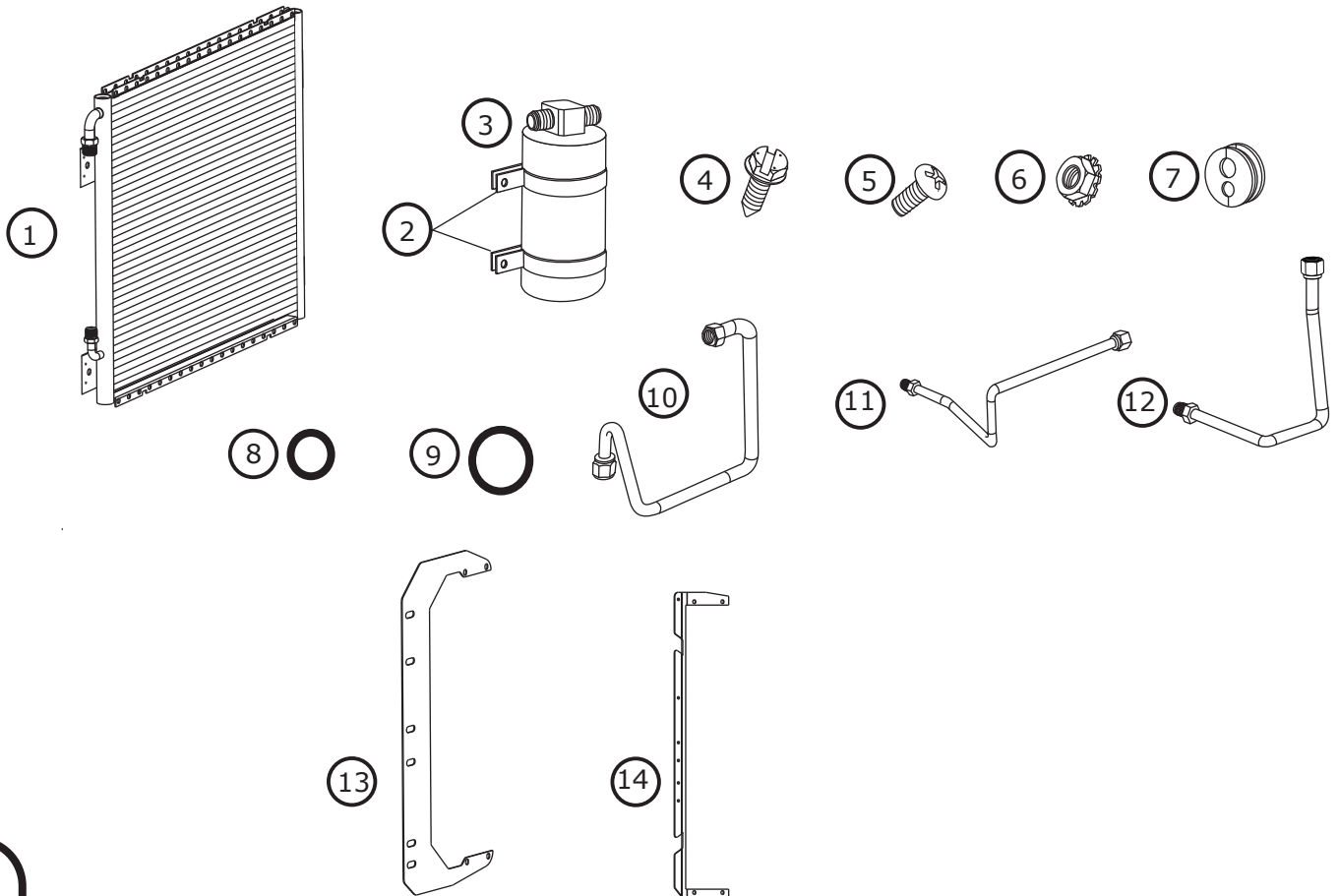



Engine Compartment

1. Remove core support cover.
2. Remove OEM fan & fan shroud.
3. Drain & remove radiator.

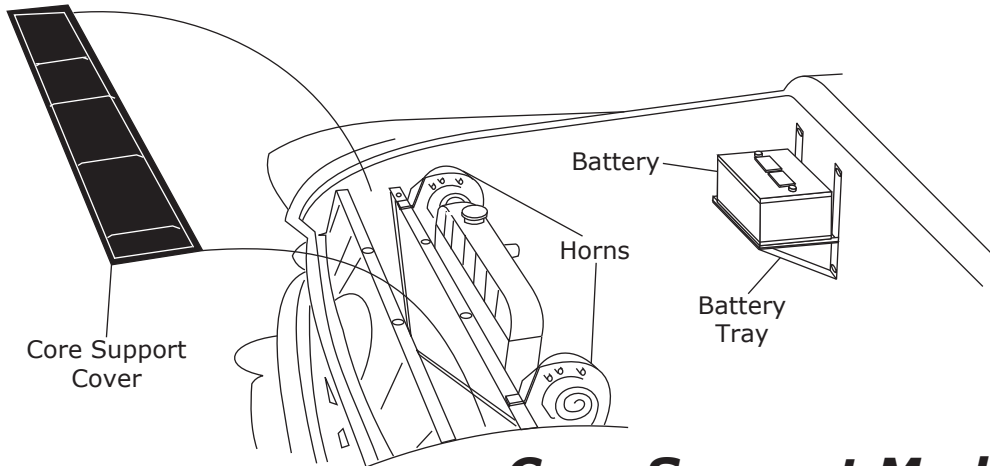

Core Support Modification

1. Drill a 1 1/4" hole through passenger side core support on engine side using measurements below.
2. Install 2-hole grommet.

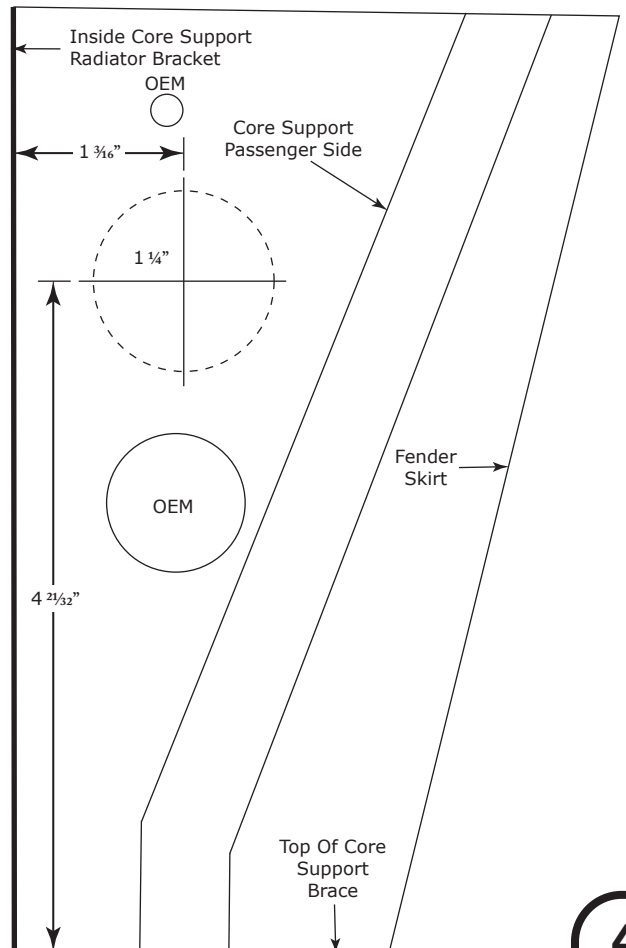
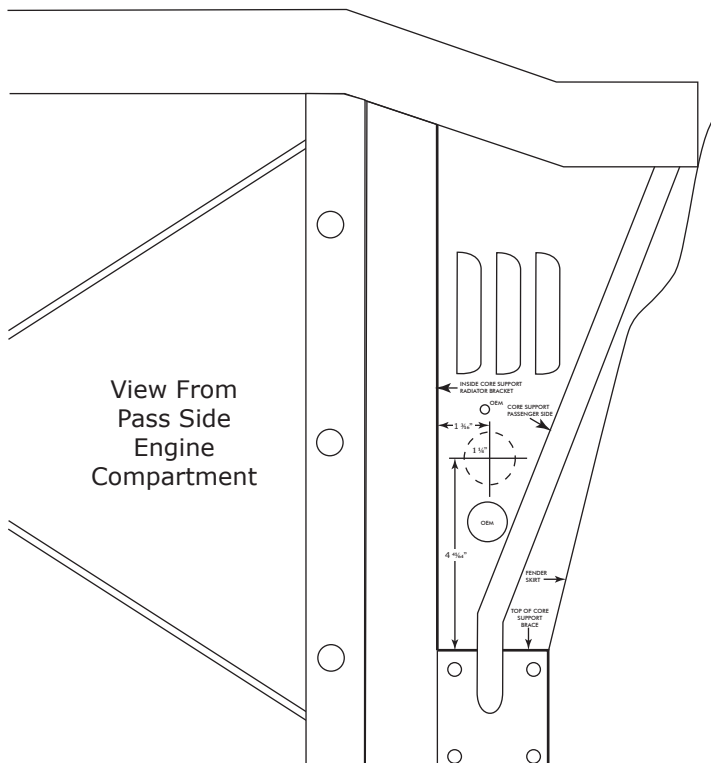



Condenser Mounting Bracket Installation

1. Install condenser mounting brackets onto back of condenser using 10-24 X 3/8" pan head screws and 10-24 nuts with star washers. **Note: Bracket mounts through the 2nd & 4th holes of the condenser.**

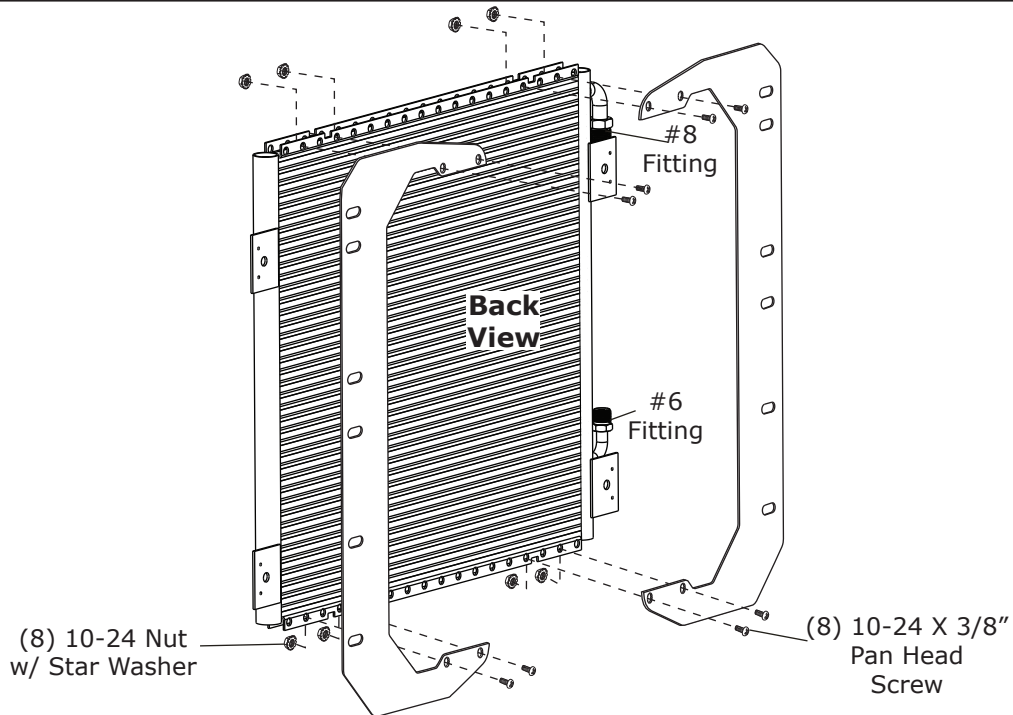

Drier Bracket Installation

1. Install drier bracket onto condenser using 10-24 X 3/8" pan head screws and 10-24 nuts with star washers. **Note: Bracket mounts through the 1st and 3rd holes of the condenser.**

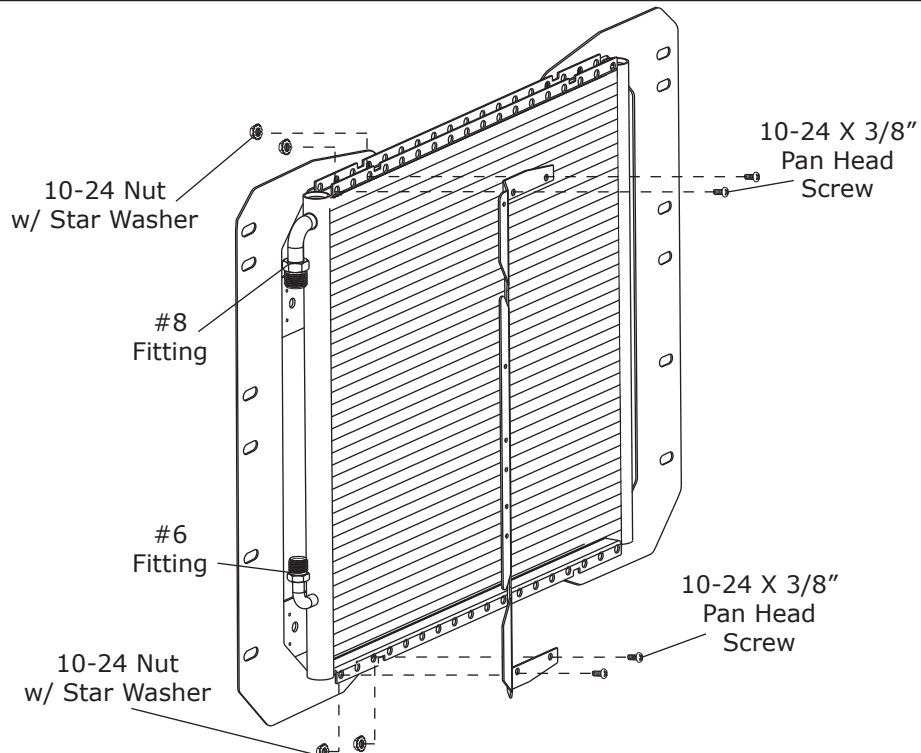



Drier Installation

1. Install drier clamps on drier as shown.
2. Using #10 X 1/2" sheet metal screws, install drier on bracket in the 3rd and 6th holes from the top, as shown.

NOTE: Refrigerant flow through drier is IN from condenser, OUT to evaporator.

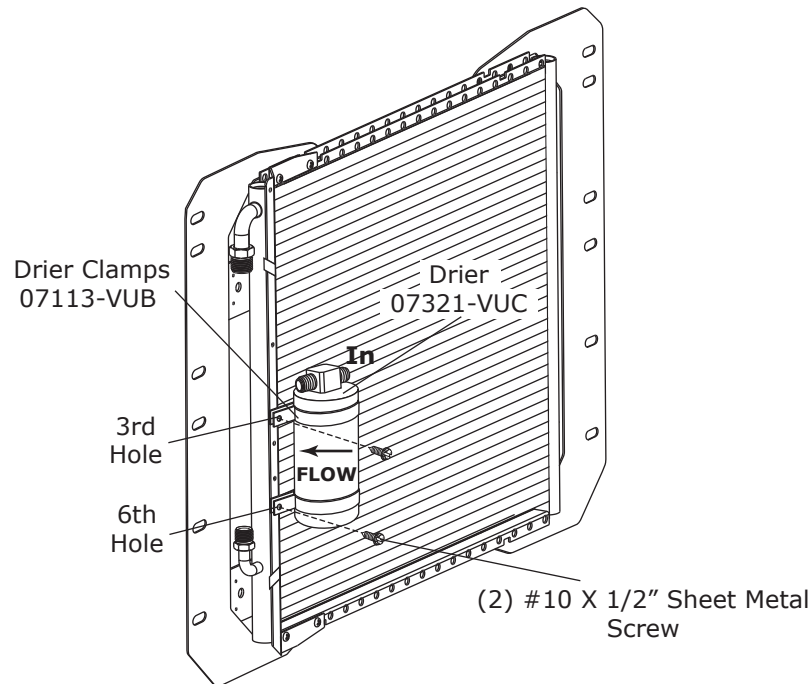

Hardline Installation

1. Lubricate (2) #6 O-rings and install the #6 drier/condenser hardline as shown. Tighten fittings. See Figure 1, below. **NOTE: Oil is supplied with hose kit.**

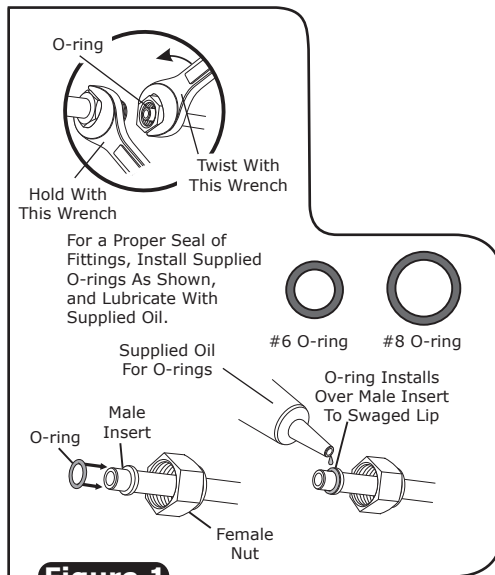
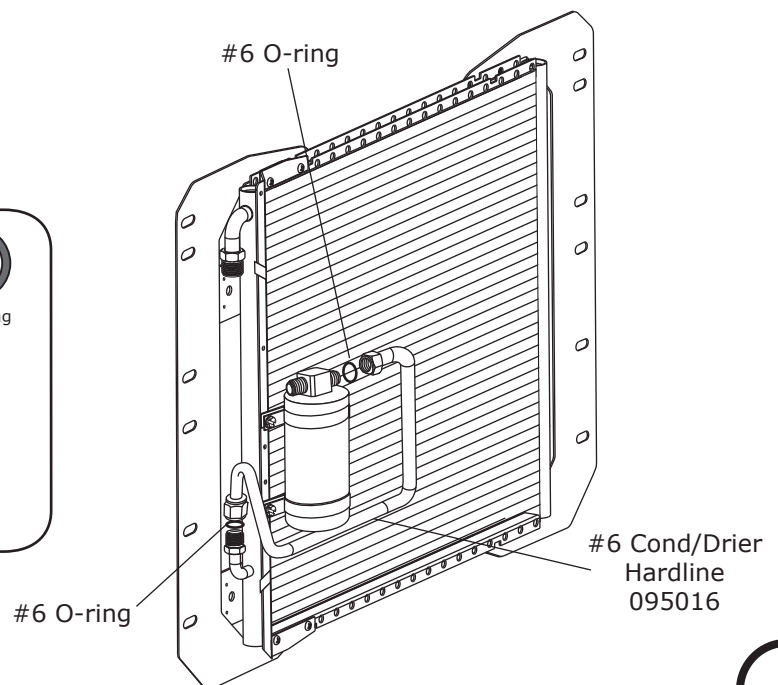
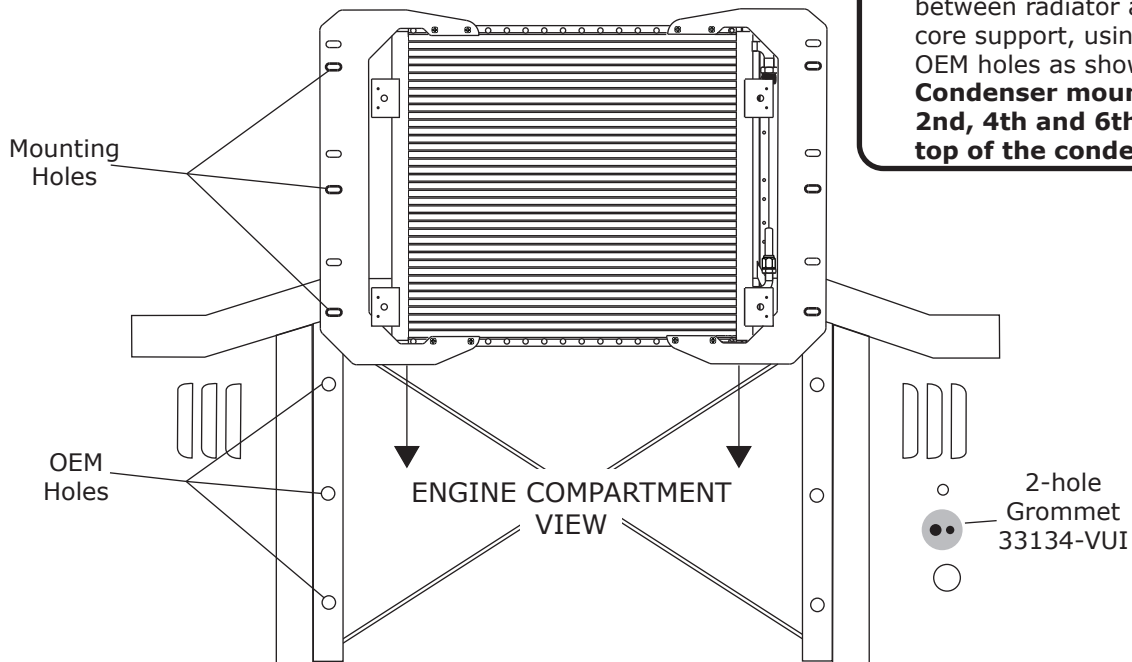

Figure 1





Condenser Installation



1. Install condenser/drier assembly between radiator and engine side of core support, using OEM bolts and OEM holes as shown. **Note: Condenser mounts using the 2nd, 4th and 6th holes from the top of the condenser brackets.**

Hardline Installation

1. Lubricate a #6 O-ring (See Figure 1, Page 6) and install the #6 hardline. Tighten fittings as shown. **NOTE: Oil is supplied with hose kit.**
2. Lubricate a #8 O-ring and install the #8 hardline as shown.

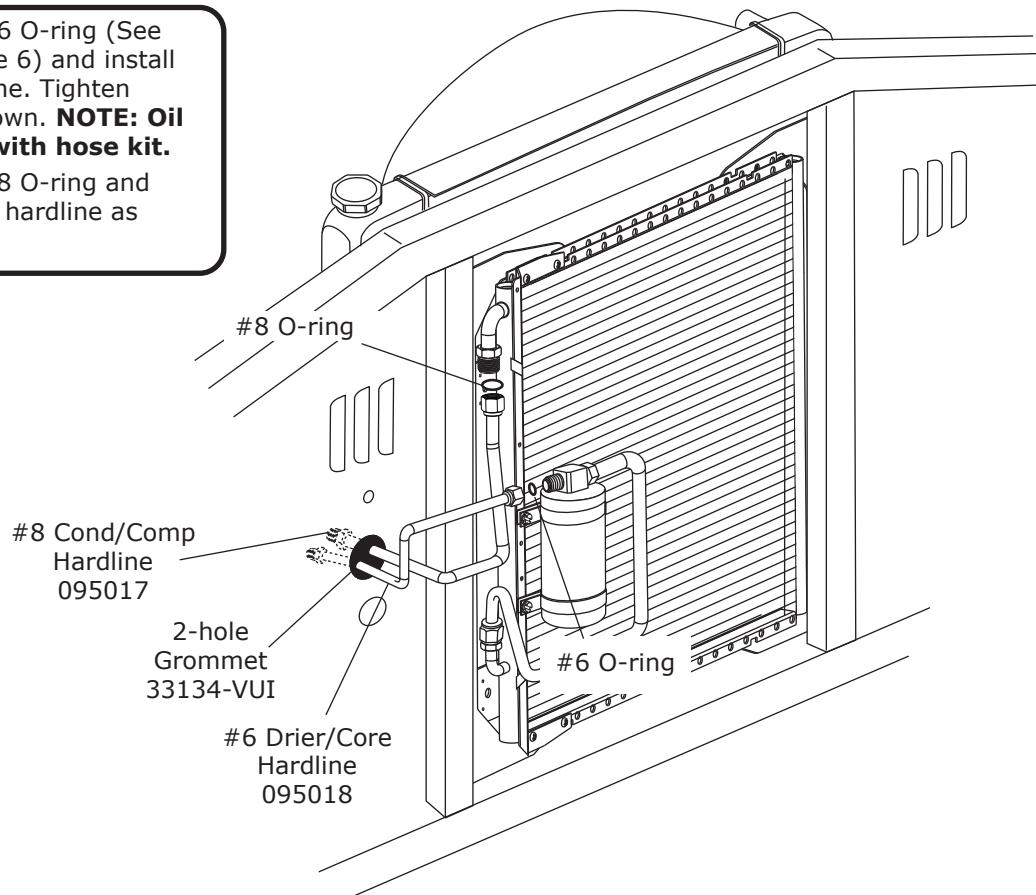



Packing List: 1958-59 Chevy Pickup Condenser Kit With Drier (021558)

No.	Qty.	Part No.	Description
1.	1	03768-VUC	17" X 19" Super Flow Cond
2.	2	07113-VUB	Drier Clamp
3.	1	07321-VUC	Drier
4.	2	18247-VUB	#10 X 1/2" Hex Screw
5.	12	18249-VUB	10-24 X 3/8" Pan Head Screw
6.	12	18260-VUB	10-24 Nut w/ Star Washer
7.	1	33134-VUI	2-hole Grommet
8.	3	33857-VUF	#6 O-ring
9.	1	33858-VUF	#8 O-ring
10.	1	095016	Hardline 58-59 Chevy Pickup #6 Cond/Drier
11.	1	095018	Hardline 58-59 Chevy Pickup #6 Drier/Core
12.	1	095017	Hardline 58-59 Chevy Pickup #8 Cond/Comp
13.	2	644091	Brkt 58-66 Chevy Pickup Cond
14.	1	644090	Brkt 58-66 Chevy Pickup Drier



Checked By: _____
 Packed By: _____
 Date: _____

