



an ISO 9001:2015 Registered Company

1973-74 Chevrolet Nova

Condenser Kit *with* Drier
(021173)



18865 Goll St. San Antonio, TX 78266
Phone: 800-862-6658
Sales: sales@vintageair.com
Tech Support: tech@vintageair.com
www.vintageair.com



www.vintageair.com

Table of Contents

Cover.....	1
Table of Contents.....	2
Packing List/Parts Disclaimer.....	3
Important Notice.....	4
Core Support Measurements.....	5
Core Support Modification.....	6
Mounting Bracket Installation.....	7
Radiator Removal, Hood Latch Assembly, Lubricating O-rings.....	8
Condenser Installation.....	9
Hood Latch Installation, Binary Switch Installation.....	10
Drier Bracket Installation.....	11
Hardline Installation.....	12
Hardline Installation (Cont.), Final Steps.....	13
Packing List.....	14



www.vintageair.com

Packing List: Condenser Kit (021173)

No.	Qty.	Part No.	Description
1.	1	03767-VUC	Condenser, 14" x 24" Parallel Flow
2.	1	07321-VUC	Drier
3.	10	18249-VUB	Screw, 10-24 x 3/8", Pan Head
4.	10	18260-VUB	Nut with Star Washer, 10-24
5.	3	18247-VUB	Screw, #10 x 1/2", Sheet Metal
6.	1	18266-VUB	Screw, #14 x 3/4", Sheet Metal
7.	1	18308-VUB	Bolt, 5/16-18 x 1", Hex
8.	1	18151-VUB	Locknut, 5/16"
9.	3	18290-VUB	Bolt, 1/4-20 x 1", Hex
10.	4	18125-VUB	Washer, 1/4", Flat
11.	2	18152-VUB	Nut with Star Washer, 1/4-20
12.	2	33857-VUF	O-ring, #6
13.	2	33858-VUF	O-ring, #8
14.	1	091690	Hardline, #8 Condenser/Compressor
15.	1	091691	Hardline, #6 Drier/Evaporator
16.	1	35368-VCG	Hardline, #6 Drier/Condenser
17.	1	643055	Bracket, Top Mounting
18.	1	643056	Bracket, Bottom Mounting
19.	1	11079-VUS	Binary Switch, Male
20.	1	23127-VUW	Compressor Lead, 72"
21.	1	31603-VUD	Adel Clamp, #4
22.	1	31600-VUD	Adel Clamp, #2
23.	1	644172	Bracket, Hardline Support
24.	1	659981	Bracket, Condenser/Drier, Passenger Side
25.	2	18611-VUB	Washer, 5/16", Flat
26.	1	33134-VUI	Grommet, 2-Hole
27.	1	41117-VUP	Refrigerant Oil
28.	1	644166	Template, Core Support Hardline

**** Before beginning installation, open all packages and check contents of shipment. Please report any shortages directly to Vintage Air within 15 days. After 15 days, Vintage Air will not be responsible for missing or damaged items.**

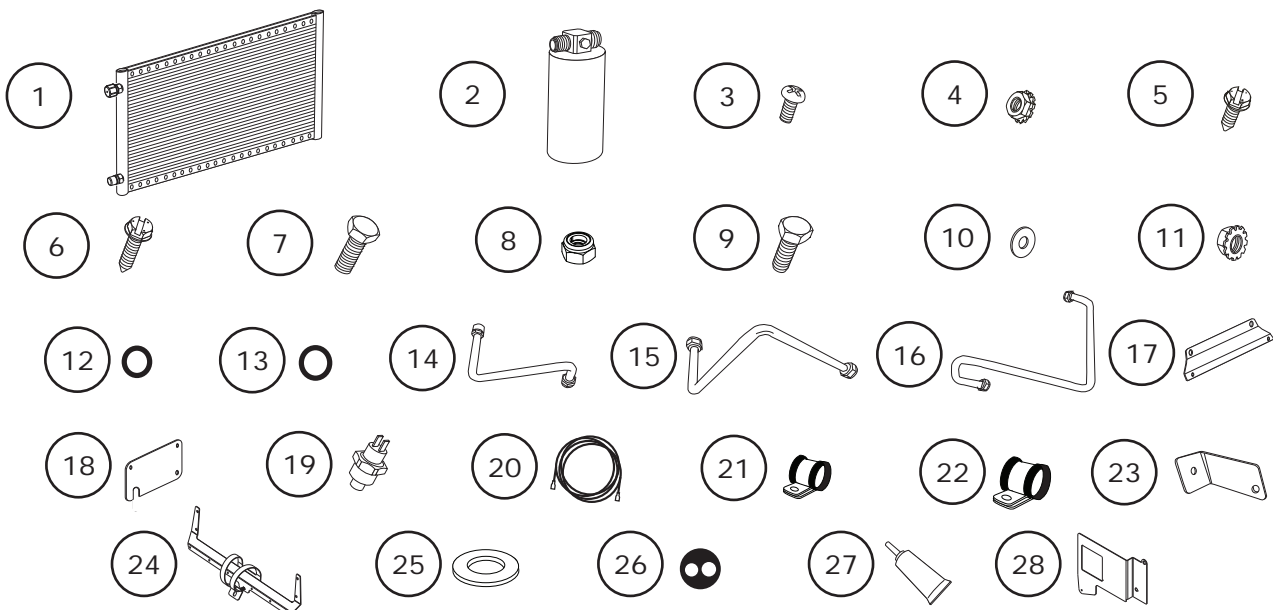

NOTE: Images may not depict actual parts and quantities. Refer to packing list for actual parts and quantities.



www.vintageair.com

Important Notice—Please Read

For Maximum System Performance, Vintage Air Recommends the Following:

NOTE: Vintage Air systems are designed to operate with R134a refrigerant only. Use of any other refrigerant could damage your A/C system and/or vehicle, and possibly cause a fire, in addition to potentially voiding the warranties of the A/C system and its components.

Refrigerant Capacities:

Vintage Air System: 1.8 lbs. (28.8 oz.) or 816 grams of **R134a**, charged by weight with a quality charging station or scale. **NOTE: Use of the proper type and amount of refrigerant is critical to system operation and performance.**

Other Systems: Consult manufacturer's guidelines.

Lubricant Capacities:

New Vintage Air-supplied Sanden Compressor: No additional oil needed (Compressor is shipped with proper oil charge).

All Other Compressors: Consult manufacturer (Some compressors are shipped dry and will need oil added).

Safety Switches

Your Vintage Air system is equipped with a binary pressure safety switch. A binary switch disengages the compressor clutch in cases of extreme low pressure conditions (Refrigerant Loss) or excessively high head pressure (406 PSI) to prevent compressor damage or hose rupture. A trinary switch combines Hi/Lo pressure protection with an electric fan operation signal at 254 PSI, and should be substituted for use with electric fans. Compressor safety switches are extremely important since an A/C system relies on refrigerant to circulate lubricant.

Service Info:

Protect Your Investment: Prior to assembly, it is critical that the compressor, evaporator, A/C hoses and fittings, hardlines, condenser and receiver/drier remained capped. Removing caps prior to assembly will allow moisture, insects and debris into the components, possibly leading to reduced performance and/or premature failure of your A/C system. This is especially important with the receiver/drier.

Additionally, when caps are removed for assembly, **BE CAREFUL!** Some components are shipped under pressure with dry nitrogen.

Evacuate the System for 35-45 Minutes: Ensure that system components (Drier, compressor, evaporator and condenser) are at a temperature of at least 85° F. On a cool day, the components can be heated with a heat gun **or** by running the engine with the heater on before evacuating. Leak check and charge to specifications.

Bolts Passing Through Cowl and/or Firewall:

To ensure a watertight seal between the passenger compartment and the vehicle exterior, for all bolts passing through the cowl and/or firewall, Vintage Air recommends coating the threads with silicone prior to installation.

Heater Hose (Not Included With This Kit):

Heater hose may be purchased from Vintage Air (Part# 31800-VUD) or your local parts retailer. Routing and required length will vary based on installer preference.



www.vintageair.com

Core Support Measurements

This kit was developed based on the measurements below, which were taken from a 1974 Chevrolet Nova with factory air core support.

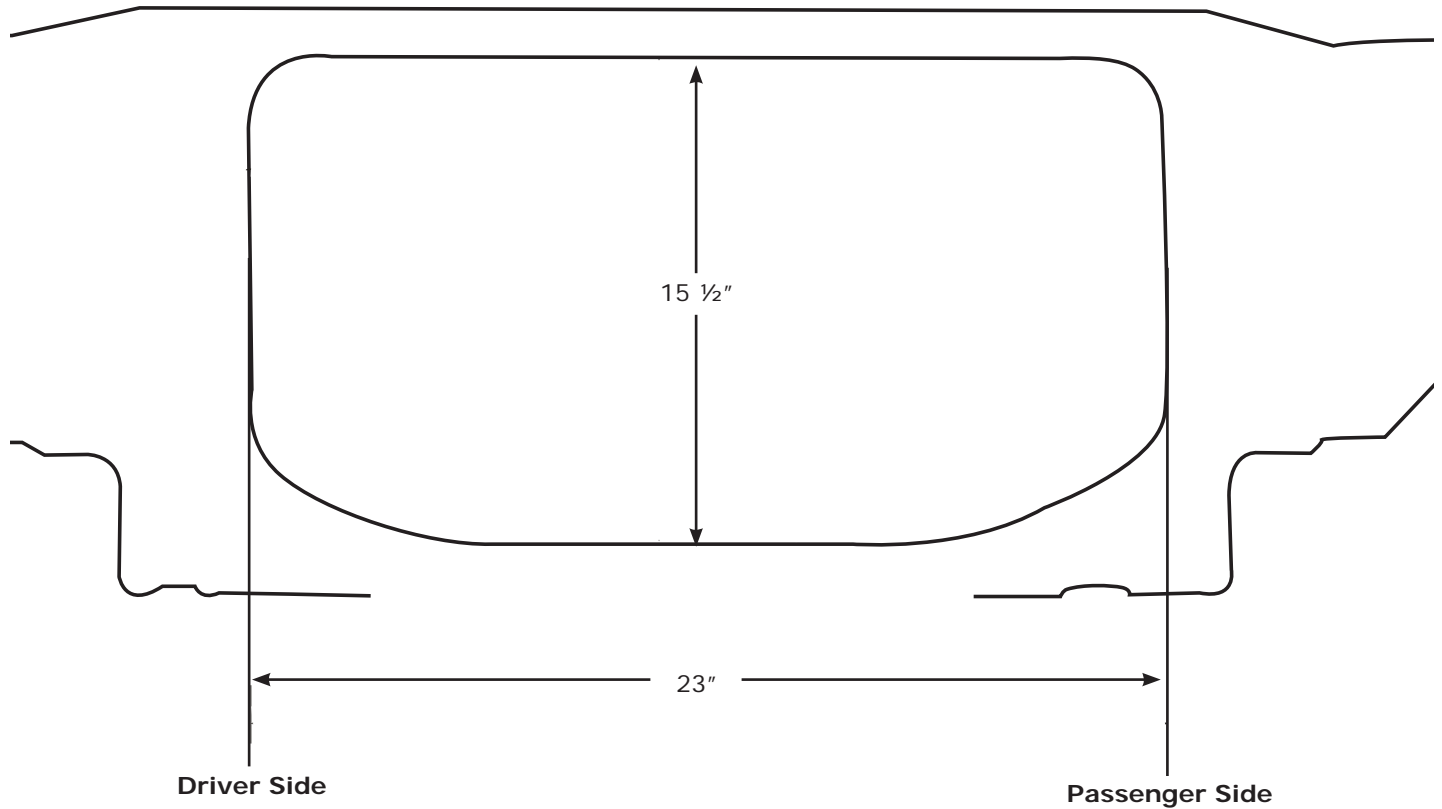



www.vintageair.com

Core Support Modification

NOTE: A modification to the firewall will be necessary in order to install the #8 condenser/compressor and #6 drier/evaporator hardlines. Some core supports may already have a 1 3/4" sized hole under the battery tray. Proceed to the Mounting Bracket Installation, Page 7 if the core support has this factory hole.

Perform the Following:

1. Disconnect battery and remove.
2. Remove the (4) bolts securing the battery tray, (2) from under the passenger side fender and (2) from the core support.
3. Place the template provided over the battery tray mount and temporarily install it with (2) bolts. Mark and drill pilot hole using a 1/8" drill bit (See Photo 1, below).
4. Remove the template from the core support.
5. Enlarge the pilot hole to 1 1/4" (See Photo 2, below). Clean and deburr the hole.

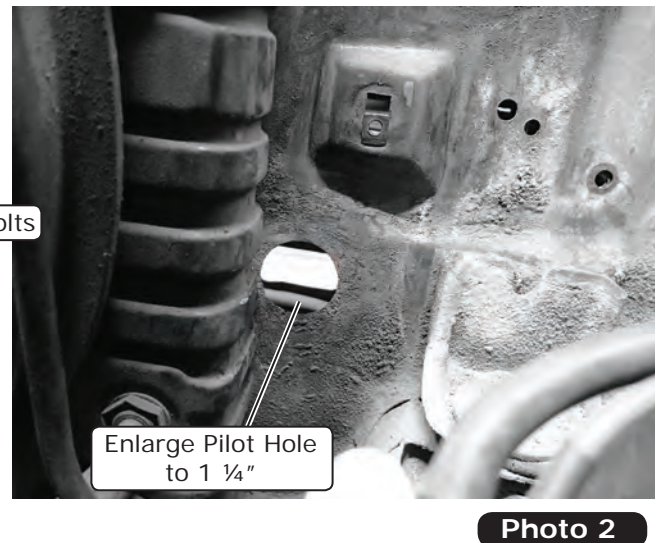
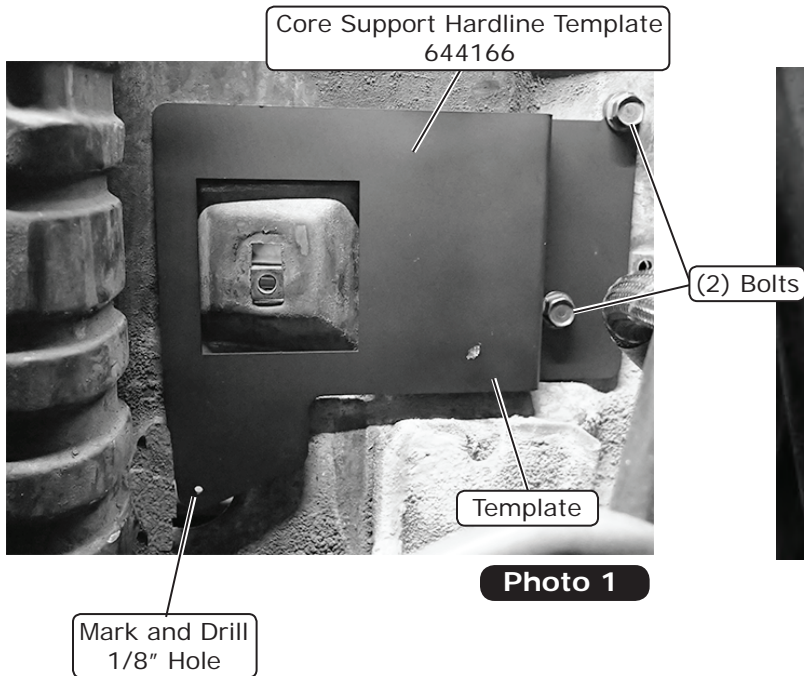



www.vintageair.com

Mounting Bracket Installation

1. Install the top mounting bracket onto the condenser using (2) 10-24 x 3/8" pan head screws and (2) 10-24 nuts with star washers as shown in Figure 1, below. **NOTE: The bracket mounts through the 6th and 13th holes from the left side of the condenser.**
2. Install the bottom mounting bracket onto the condenser using (2) 10-24 x 3/8" pan head screws and (2) 10-24 nuts with star washers as shown in Figure 2, below. **NOTE: The bracket mounts through the 9th and 13th holes from the left side of the condenser (Rear View).**

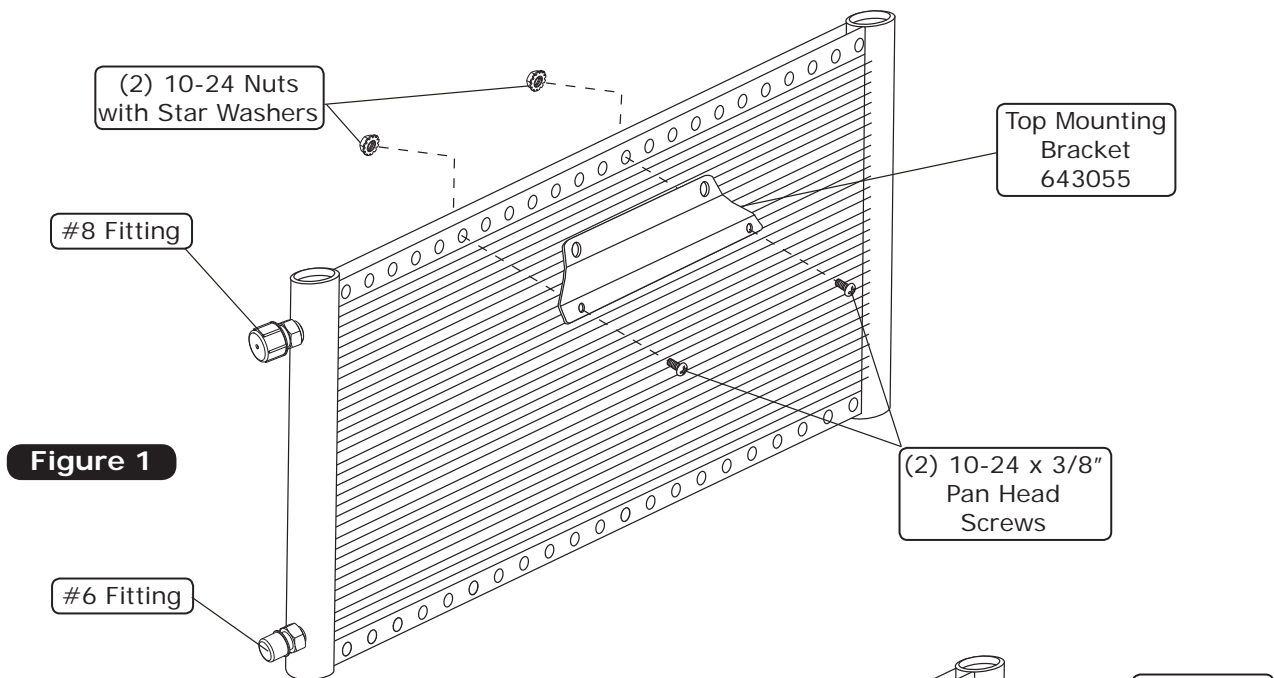

Figure 1

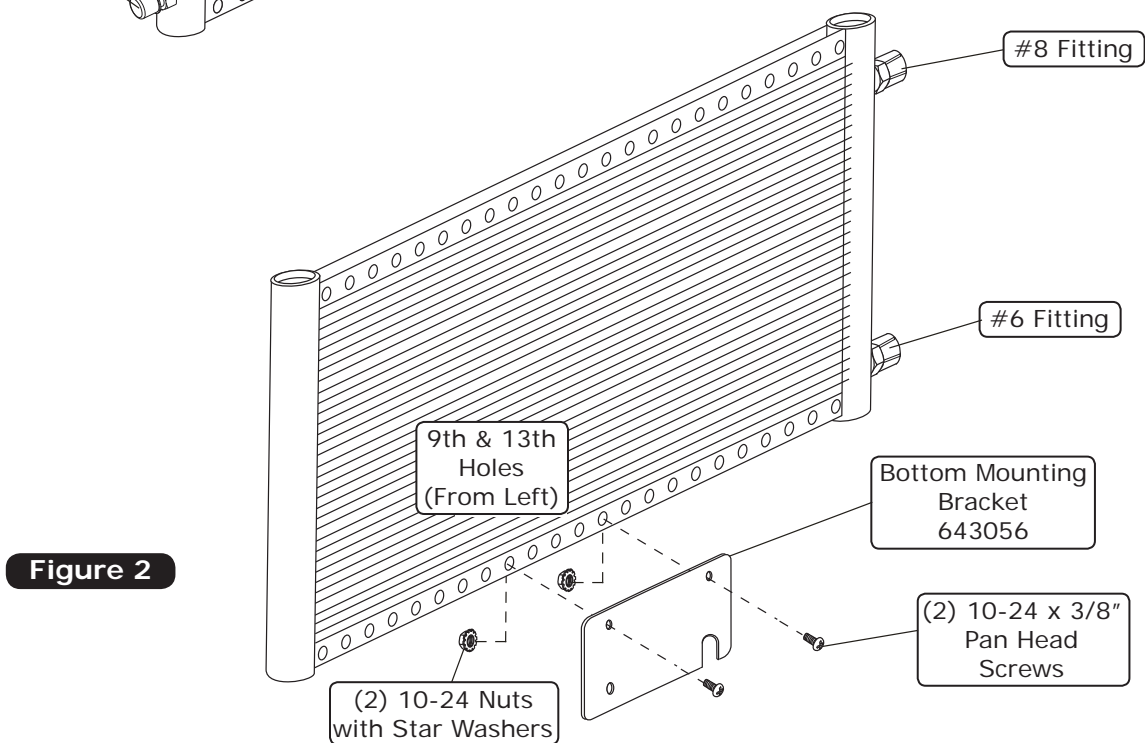

Figure 2



www.vintageair.com

Radiator Removal

1. Drain the radiator.
2. Remove the upper and lower radiator hoses and remove the radiator.

Hood Latch Assembly

1. Remove the OEM hood latch assembly (See Figure 1, below).

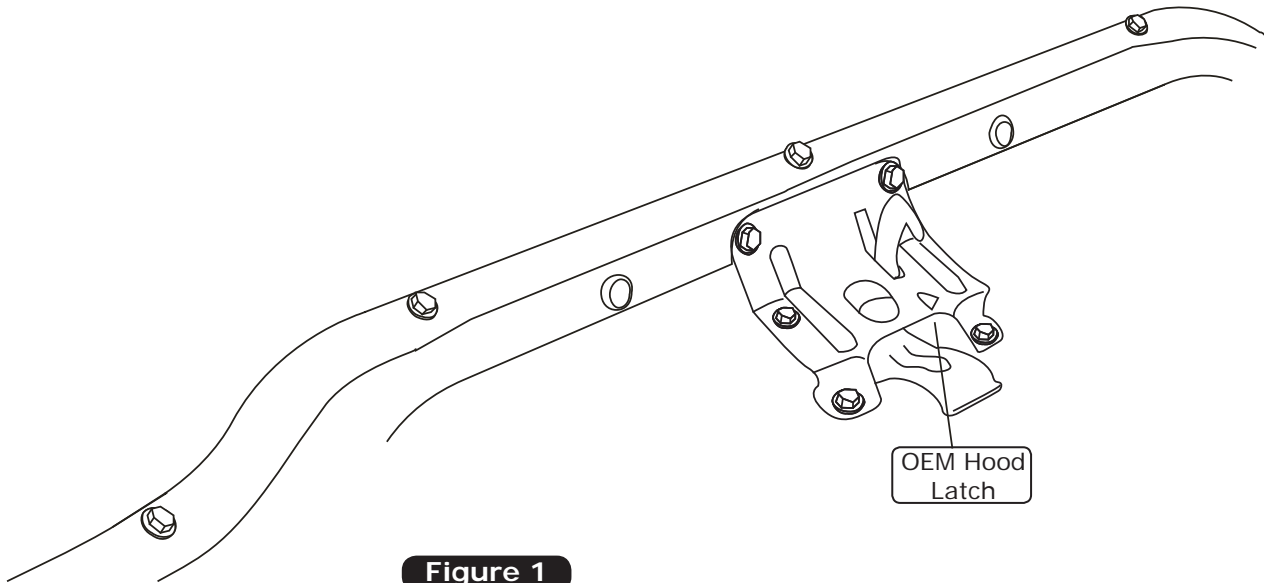

Lubricating O-rings

For a proper seal of fittings: Install supplied O-rings as shown, and lubricate with supplied oil.

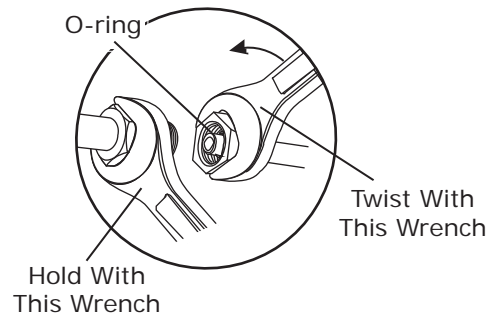
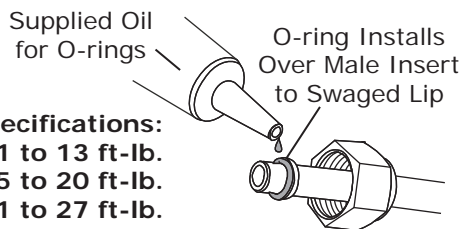
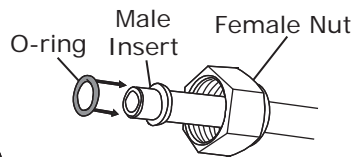
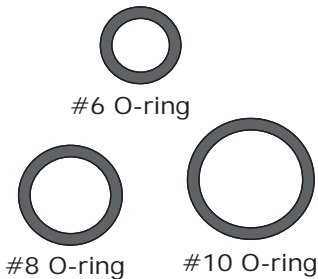

NOTE: Standard torque specifications:
 #6: 11 to 13 ft-lb.
 #8: 15 to 20 ft-lb.
 #10: 21 to 27 ft-lb.



www.vintageair.com

Condenser Installation

1. Install the condenser as shown in Figure 1, below.
2. Secure the bottom passenger side of the condenser to the core support using the OEM bolt as shown in Figure 2, below.
3. Using the driver side mounting hole as a guide, drill a 3/16" hole into the core support. Secure the condenser to the core support using a #14 x 3/4" sheet metal screw with a 1/4" flat washer as shown in Figure 2, below.

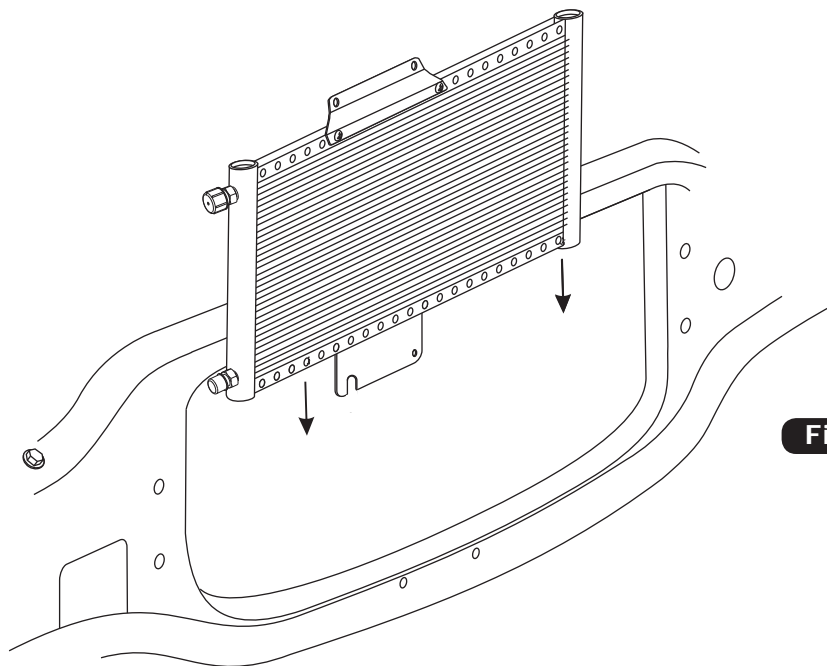

Figure 1

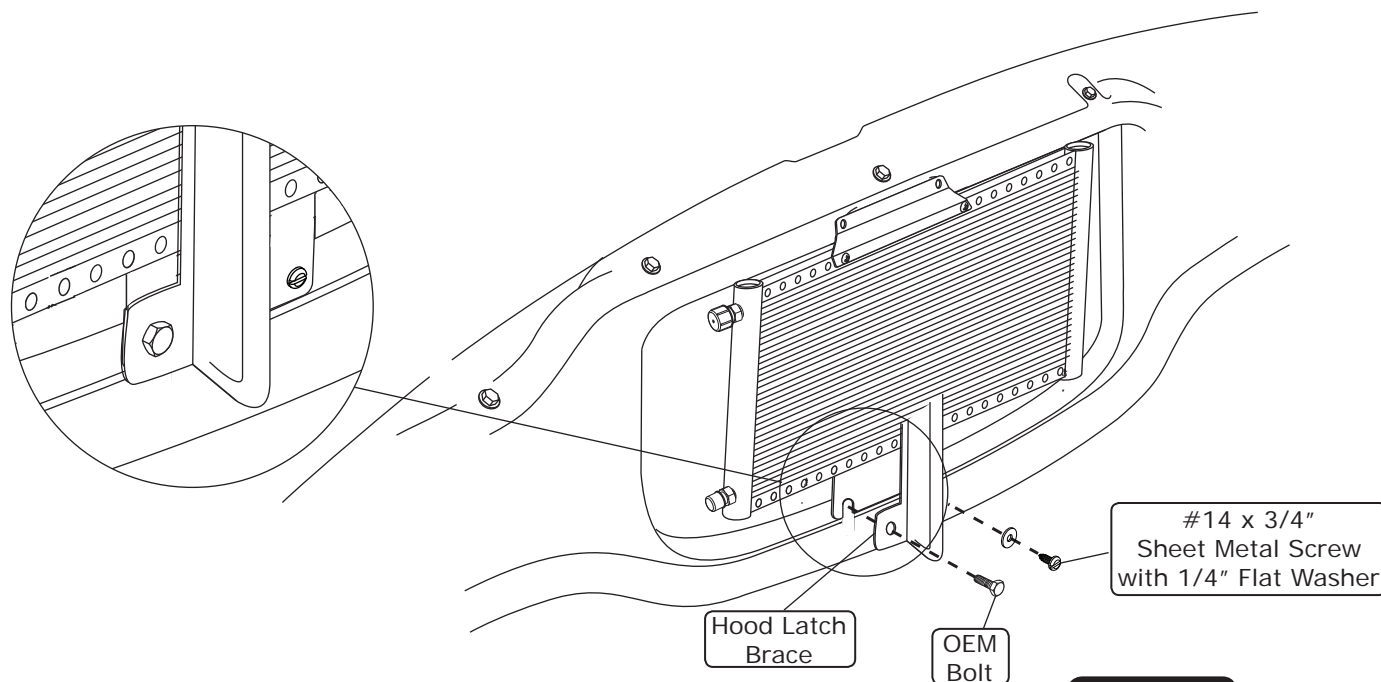

Figure 2



www.vintageair.com

Hood Latch Installation

1. Reinstall the hood latch assembly using the OEM bolts. **NOTE: Install the OEM bolts through the hood latch assembly, then the top mounting bracket and finally into the core support as shown in Figure 1, below.**

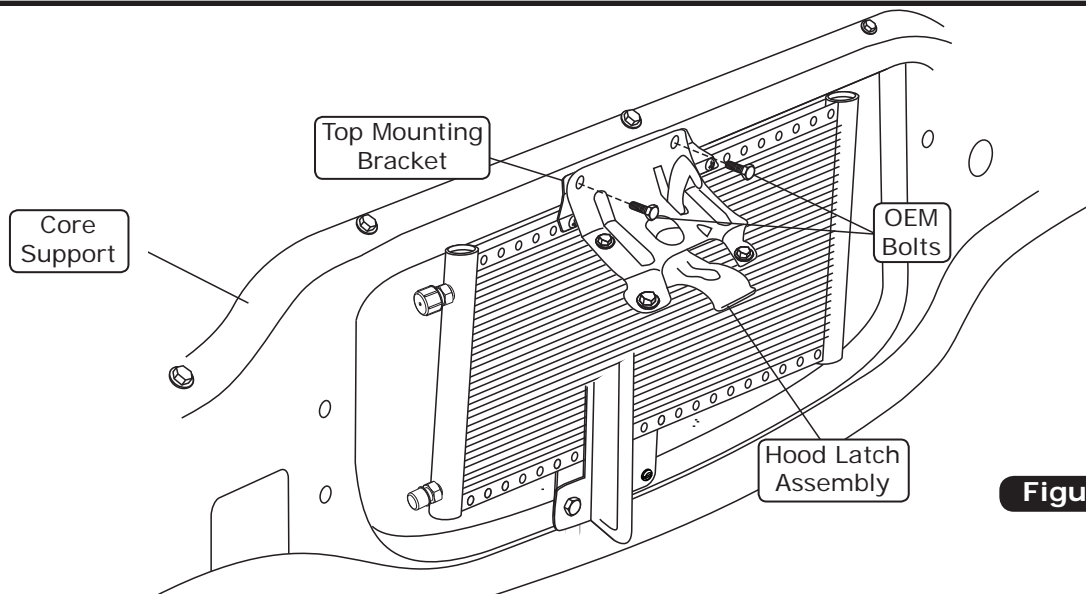

Figure 1

Binary Switch Installation

NOTE: Do not remove the caps from the drier. The drier contains a desiccant that will quickly absorb moisture from the air, causing it to lose effectiveness. For this reason, Vintage Air recommends that the drier remains capped until the installer is ready to evacuate the system.

Perform the Following:

1. Install the male binary switch onto the drier with a properly lubricated O-ring. (See Lubricating O-rings, Page 8 and Photo 1, below). **NOTE: The binary switch and the drier each come with an O-ring. Only use the binary switch O-ring and discard the one that comes with the drier. Notice the location of the "IN" on the top of the drier (See Photo 2, below), and be sure the binary switch is installed on the correct side.**

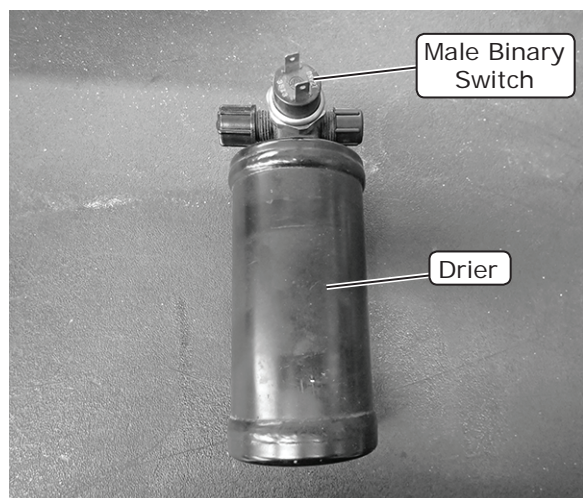

Photo 1

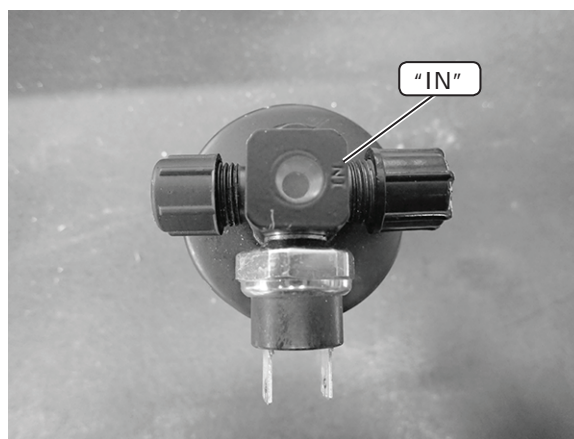

Photo 2



www.vintageair.com

Drier Bracket Installation

1. Install the drier mounting bracket onto the front of the condenser using (4) 10-24 x 3/8" pan head screws and (4) 10-24 nuts with star washers (See Figures 1 & 1a, below). **NOTE: The bracket mounts through the 1st and 3rd holes from the left side of the condenser.**
2. Install the drier into the drier bracket. Install a 1/4" washer and 1/4-20 nut with star washer onto the threaded stud of the drier bracket (See Photo 1, below). **NOTE: Do not fully tighten 1/4-20 nut at this time.**

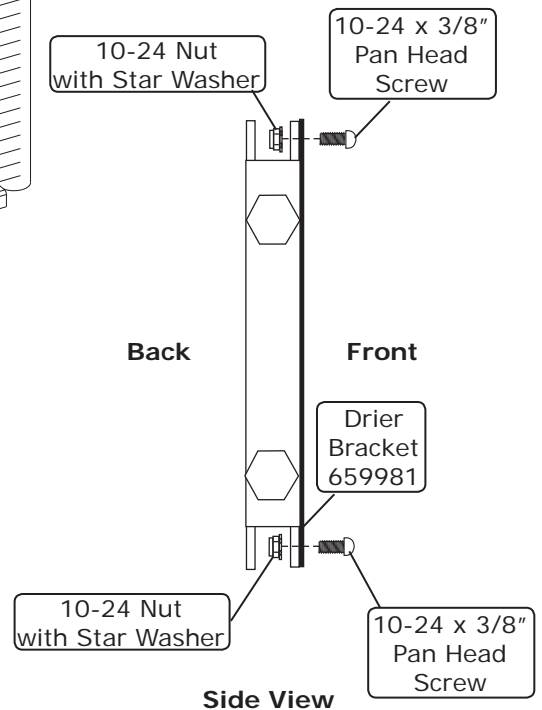
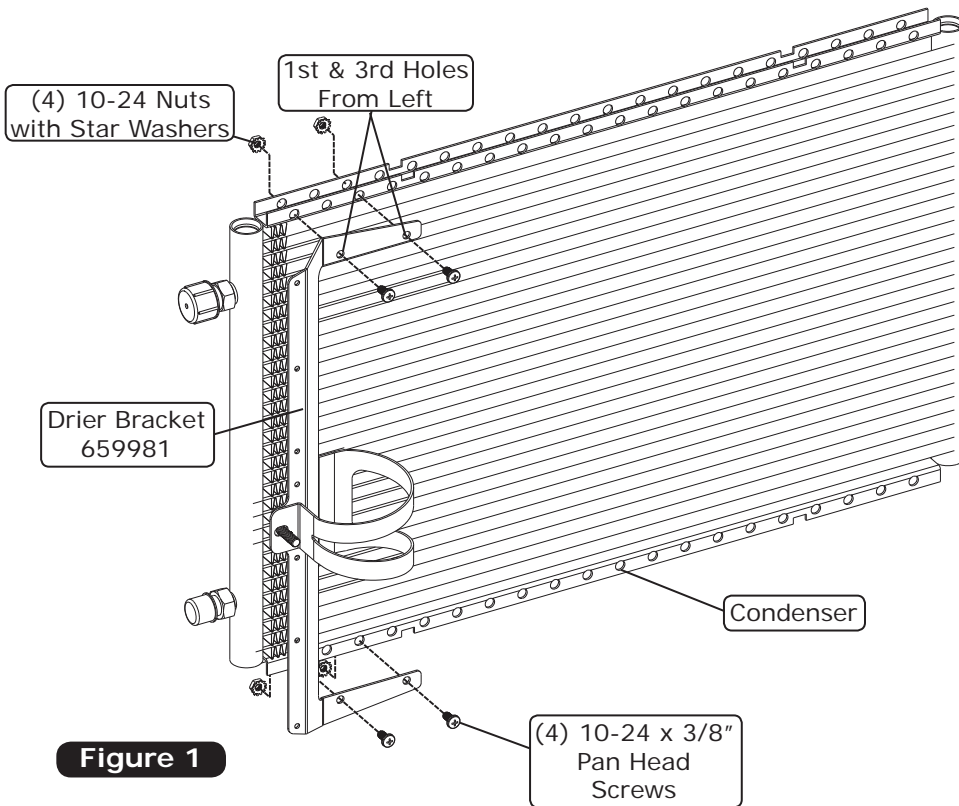
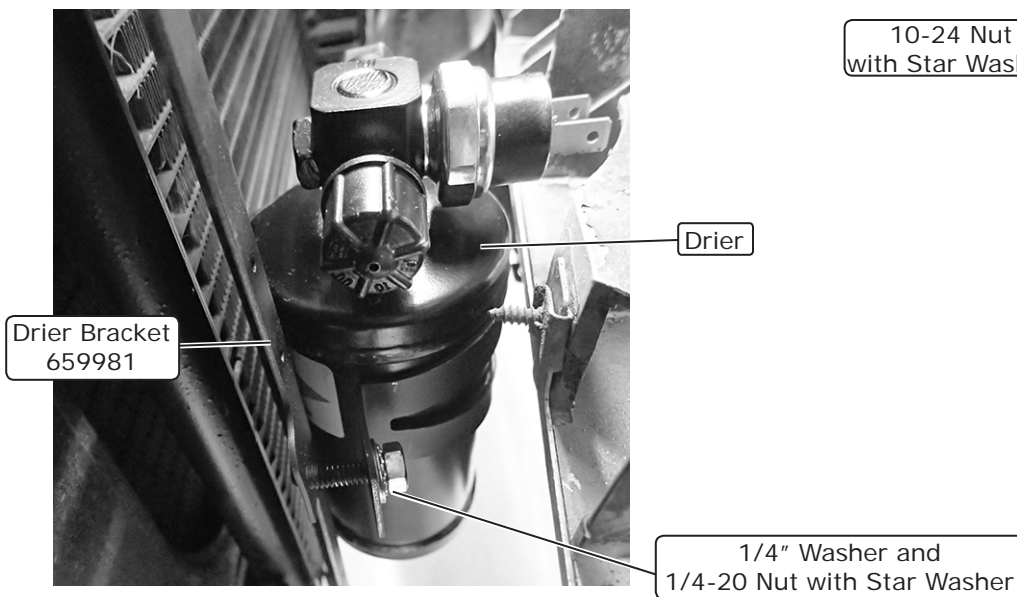

Figure 1a





www.vintageair.com

Hardline Installation

1. Properly lubricate (2) #6 O-rings, and install the #6 drier/condenser hardline onto the #6 condenser fitting and the drier (See Lubricating O-rings, Page 8 and Photo 1, below).
2. Tighten the 1/4-20 nut with star washer on the drier bracket clamp at this time (See Photo 1, below).
3. Properly lubricate a #8 O-ring, and install the #8 condenser/compressor hardline onto the #8 condenser fitting (See Lubricating O-rings, Page 8 and Photo 2, below).
4. Properly lubricate a #6 O-ring, and install the #6 drier/evaporator hardline onto the other end of the drier (See Lubricating O-rings, Page 8 and Photo 3, below).

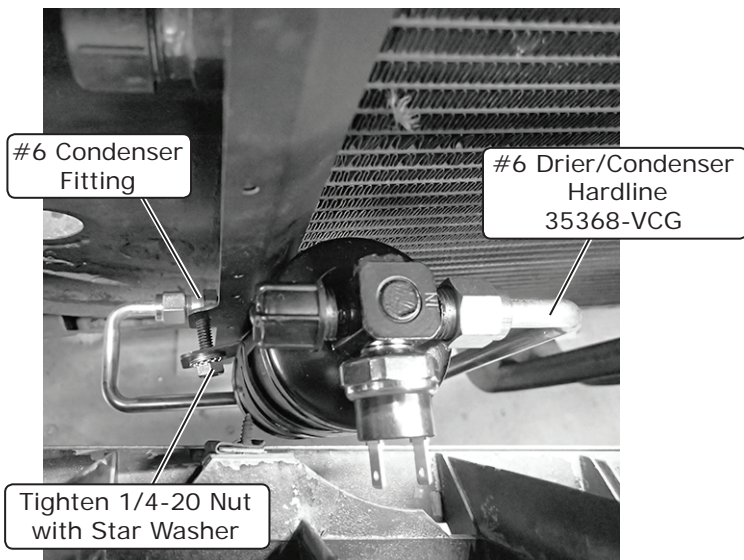

Photo 1

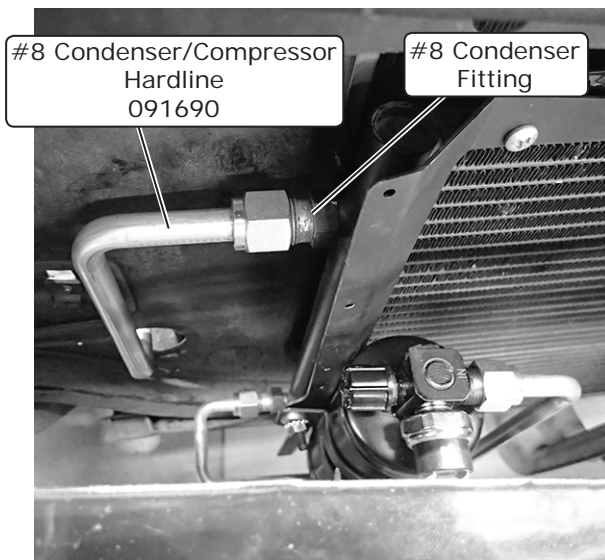

Photo 2

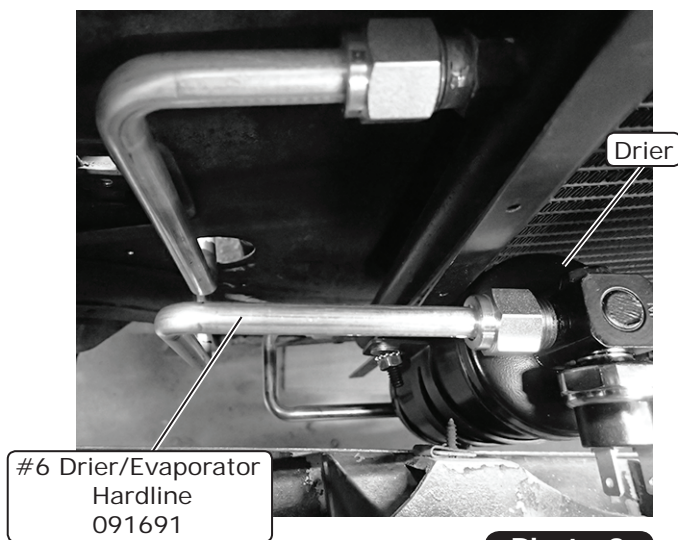

Photo 3



www.vintageair.com

Hardline Installation (Cont.)

5. Install the 2-hole grommet onto the #8 and #6 condenser hardlines and into the 1 1/4" hole (See Photo 4, below). **NOTE: If the core support has a 1 3/4" OEM hole in this location, the 2-hole grommet will not be used.**
6. Install the #4 Adel clamp onto the #8 condenser/compressor hardline and the #2 Adel clamp onto the #6 drier/evaporator hardline (See Photo 5, below).
7. Secure both Adel clamps onto the hardline support bracket using a 10-24 x 3/8" pan head screw and 10-24 nut with star washer (See Photo 6, below).
8. Using the hardline support bracket as a template, drill a mounting hole using a 5/32 drill bit, and attach the bracket to the core support using a #10 x 1/2" sheet metal screw (See Photo 7, below).

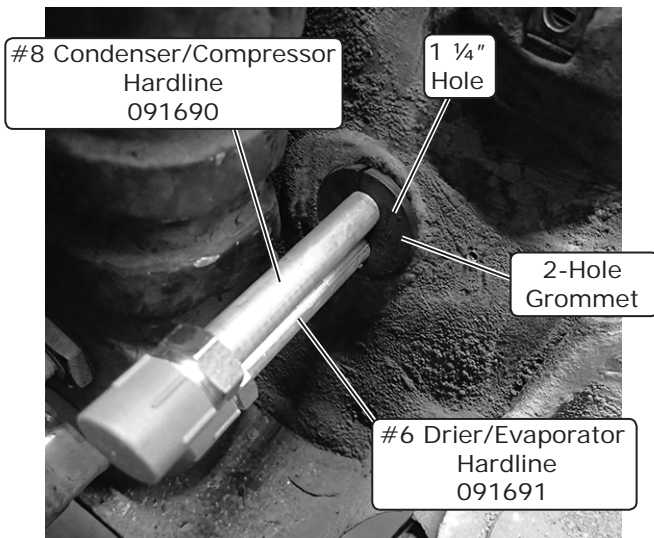

Photo 4

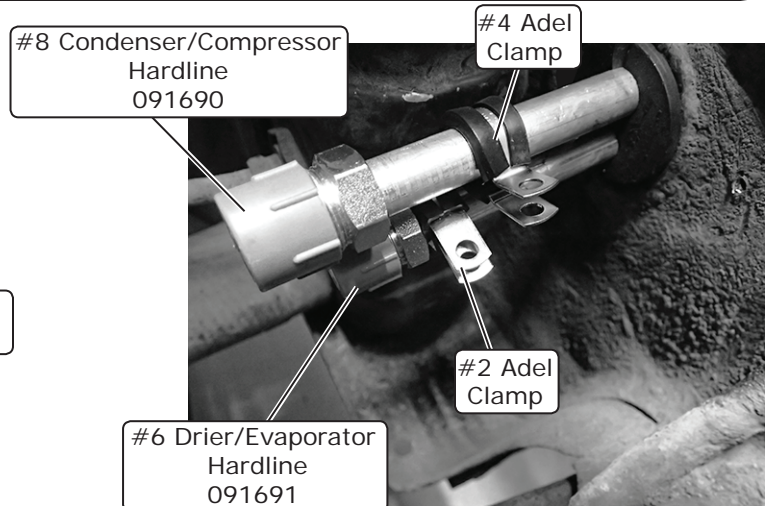

Photo 5

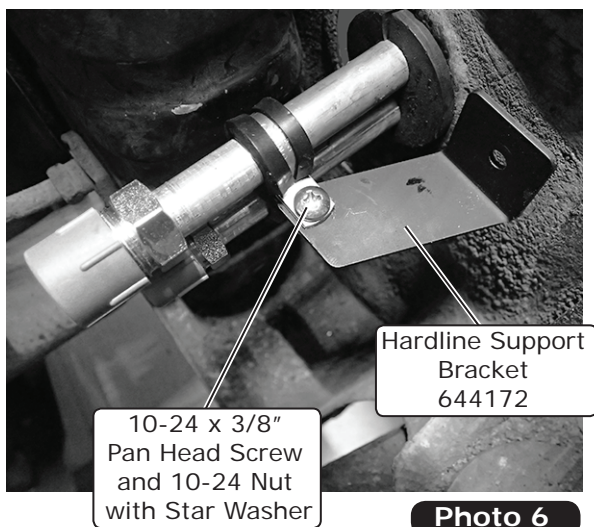

Photo 6

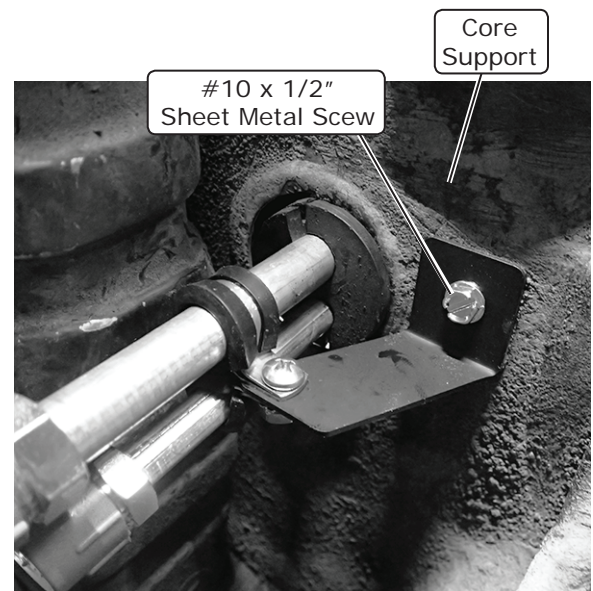

Photo 7

Final Steps

1. Reinstall and/or reconnect all remaining items removed or disconnected. This concludes the condenser kit portion of your installation.



www.vintageair.com

Packing List: Condenser Kit (021173)

No.	Qty.	Part No.	Description
1.	1	03767-VUC	Condenser, 14" x 24" Parallel Flow
2.	1	07321-VUC	Drier
3.	10	18249-VUB	Screw, 10-24 x 3/8", Pan Head
4.	10	18260-VUB	Nut with Star Washer, 10-24
5.	3	18247-VUB	Screw, #10 x 1/2", Sheet Metal
6.	1	18266-VUB	Screw, #14 x 3/4", Sheet Metal
7.	1	18308-VUB	Bolt, 5/16-18 x 1", Hex
8.	1	18151-VUB	Locknut, 5/16"
9.	3	18290-VUB	Bolt, 1/4-20 x 1", Hex
10.	4	18125-VUB	Washer, 1/4", Flat
11.	2	18152-VUB	Nut with Star Washer, 1/4-20
12.	2	33857-VUF	O-ring, #6
13.	2	33858-VUF	O-ring, #8
14.	1	091690	Hardline, #8 Condenser/Compressor
15.	1	091691	Hardline, #6 Drier/Evaporator
16.	1	35368-VCG	Hardline, #6 Drier/Condenser
17.	1	643055	Bracket, Top Mounting
18.	1	643056	Bracket, Bottom Mounting
19.	1	11079-VUS	Binary Switch, Male
20.	1	23127-VUW	Compressor Lead, 72"
21.	1	31603-VUD	Adel Clamp, #4
22.	1	31600-VUD	Adel Clamp, #2
23.	1	644172	Bracket, Hardline Support
24.	1	659981	Bracket, Condenser/Drier, Passenger Side
25.	2	18611-VUB	Washer, 5/16", Flat
26.	1	33134-VUI	Grommet, 2-Hole
27.	1	41117-VUP	Refrigerant Oil
28.	1	644166	Template, Core Support Hardline

Checked By: _____
 Packed By: _____
 Date: _____

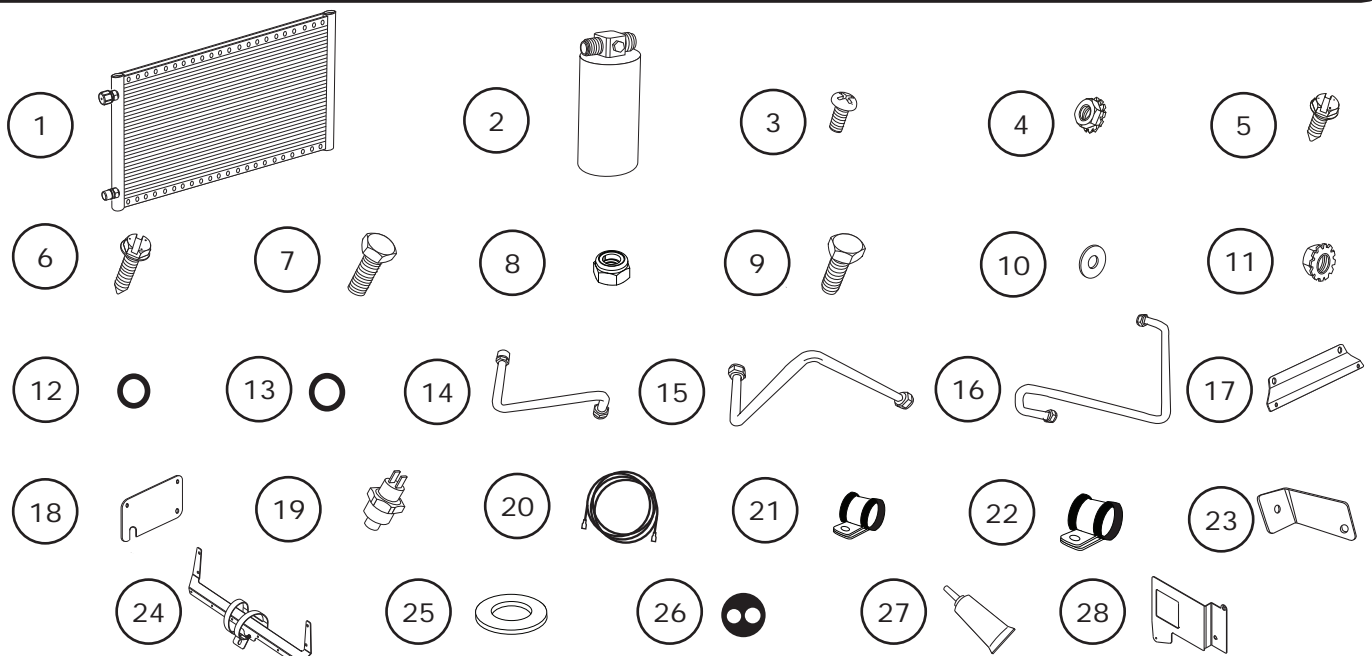

**NOTE: Images may not depict actual parts and quantities.
 Refer to packing list for actual parts and quantities.**