



an ISO 9001:2015 Registered Company

1967-72 Chevrolet Pickup

Control Panel Kit

(473080)

(473081)

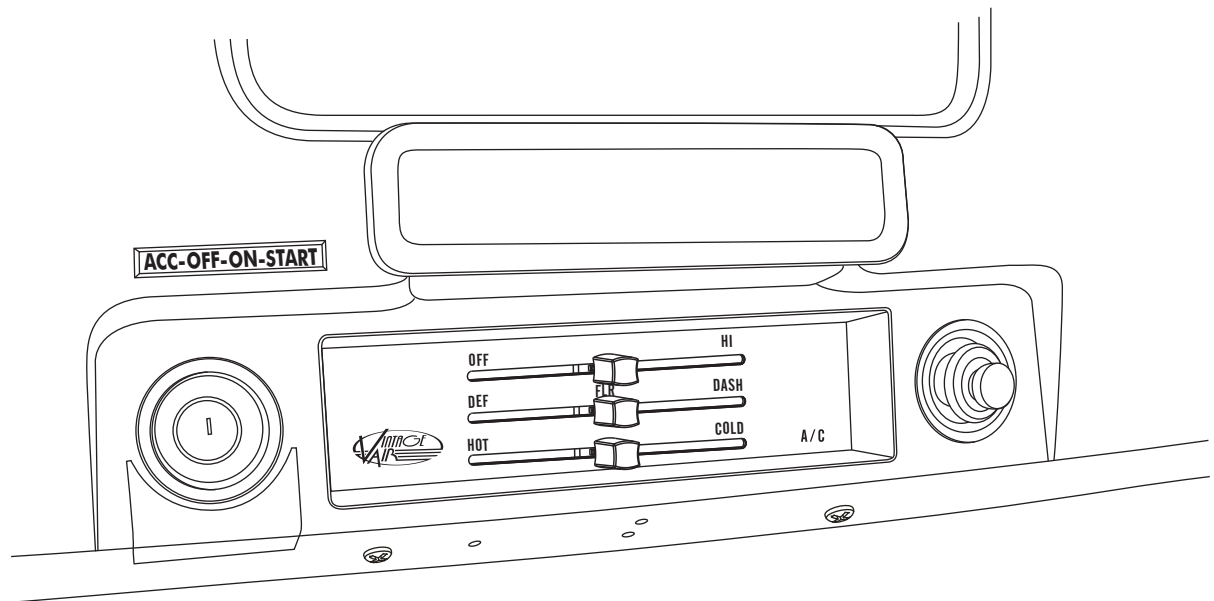

18865 Goll St. San Antonio, TX 78266

Phone: 800-862-6658

Sales: sales@vintageair.com

Tech Support: tech@vintageair.com

www.vintageair.com



www.vintageair.com

Table of Contents

Cover.....	1
Table of Contents.....	2
Packing List (Machined Finish)/Parts Disclaimer.....	3
Packing List (Black Anodized)/Parts Disclaimer.....	4
OEM Control Panel Removal.....	5
Control Panel Installation.....	6
Control Panel Calibration Procedure.....	7
Control Panel Calibration Procedure (Cont.).....	8
Wiring Diagram.....	9
Operation of Controls.....	10
Packing List (Machined Finish).....	11
Packing List (Black Anodized).....	12

Important Notice—Please Read

This control panel is designed to only work with a Gen IV evaporator unit equipped with a 246204-PUA ECU. Please confirm that your unit has the proper ECU prior to installing the control panel as shown below. A replacement ECU can be purchased from Vintage Air if needed.





www.vintageair.com

Packing List: (473080) Machined Finish Control Panel

No.	Qty.	Part No.	Description
1.	1	473080	Control Panel Assembly, Machined Finish
2.	1	232007-VUR	Control Harness, Gen IV Universal
3.	2	180031	Nut, 5/16-18, Hex
4.	2	180030	Screw, 5/16-18 x 1/2", Pan Head

**** Before beginning installation, open all packages and check contents of shipment. Please report any shortages directly to Vintage Air within 15 days. After 15 days, Vintage Air will not be responsible for missing or damaged items.**

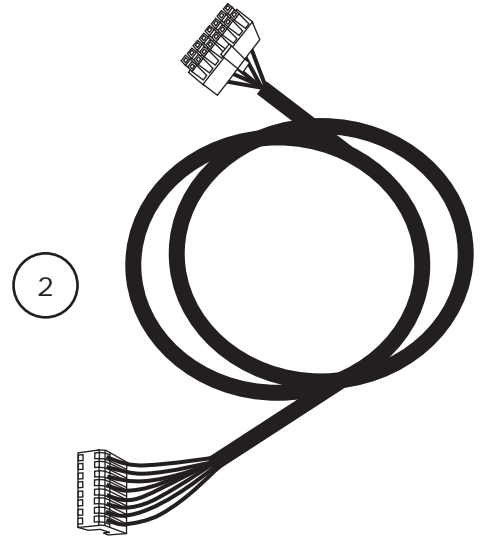
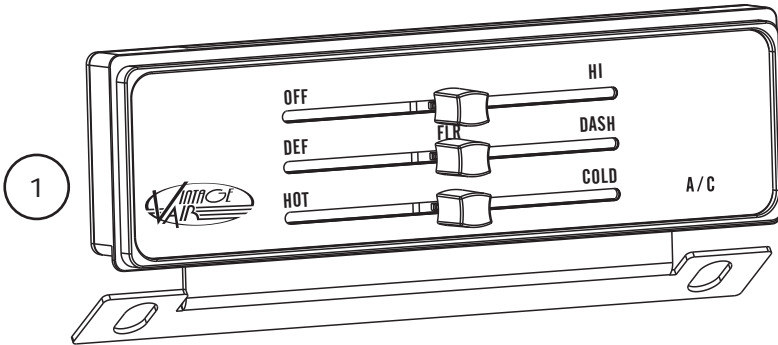

NOTE: Images may not depict actual parts and quantities. Refer to packing list for actual parts and quantities.



www.vintageair.com

Packing List: (473081) Black Anodized Control Panel

No.	Qty.	Part No.	Description
1.	1	473081	Control Panel Assembly, Black Anodized
2.	1	232007-VUR	Control Harness, Gen IV Universal
3.	2	180031	Nut, 5/16-18, Hex
4.	2	180030	Screw, 5/16-18 x 1/2", Pan Head

**** Before beginning installation, open all packages and check contents of shipment. Please report any shortages directly to Vintage Air within 15 days. After 15 days, Vintage Air will not be responsible for missing or damaged items.**

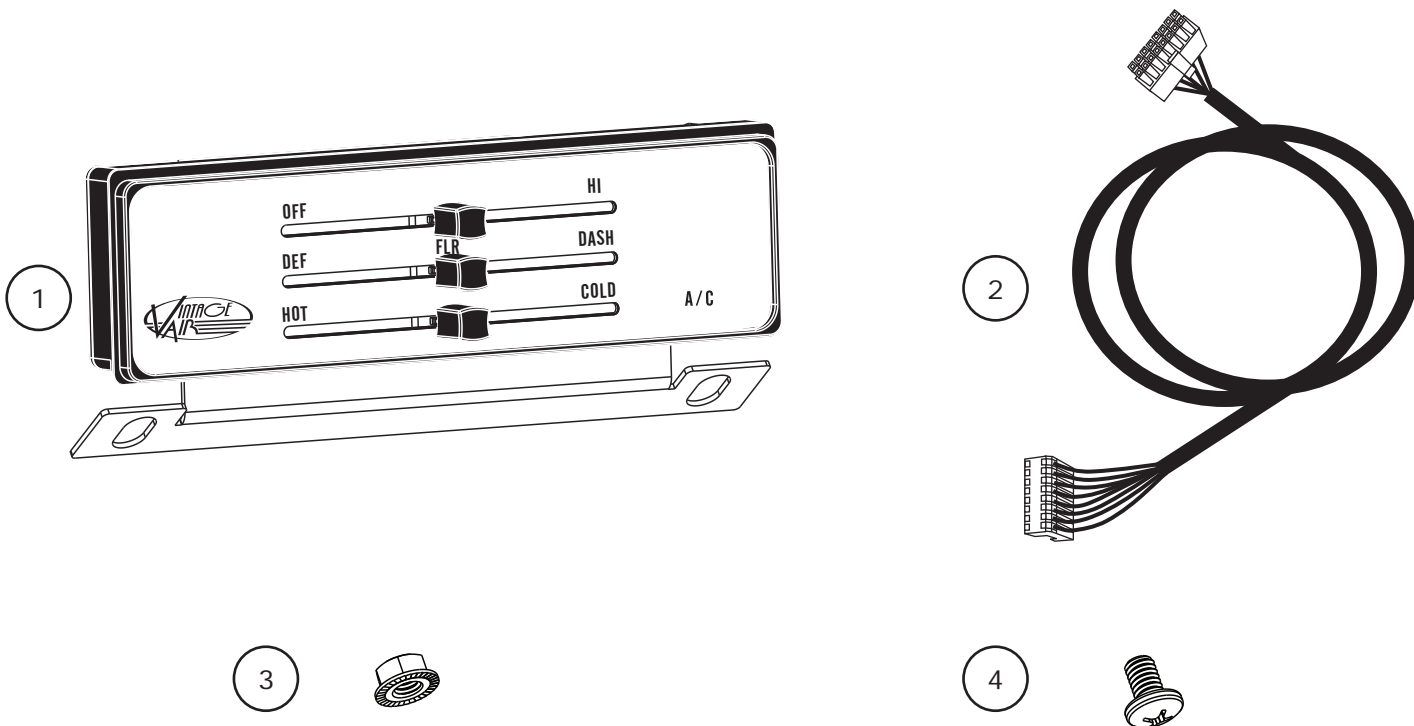

NOTE: Images may not depict actual parts and quantities. Refer to packing list for actual parts and quantities.



www.vintageair.com

OEM Control Panel Removal

1. Remove the (2) OEM screws from under the dash (See Figure 1, below).
2. Disconnect the cables and wires from the back of the control panel.
3. Remove the control panel from the dash.

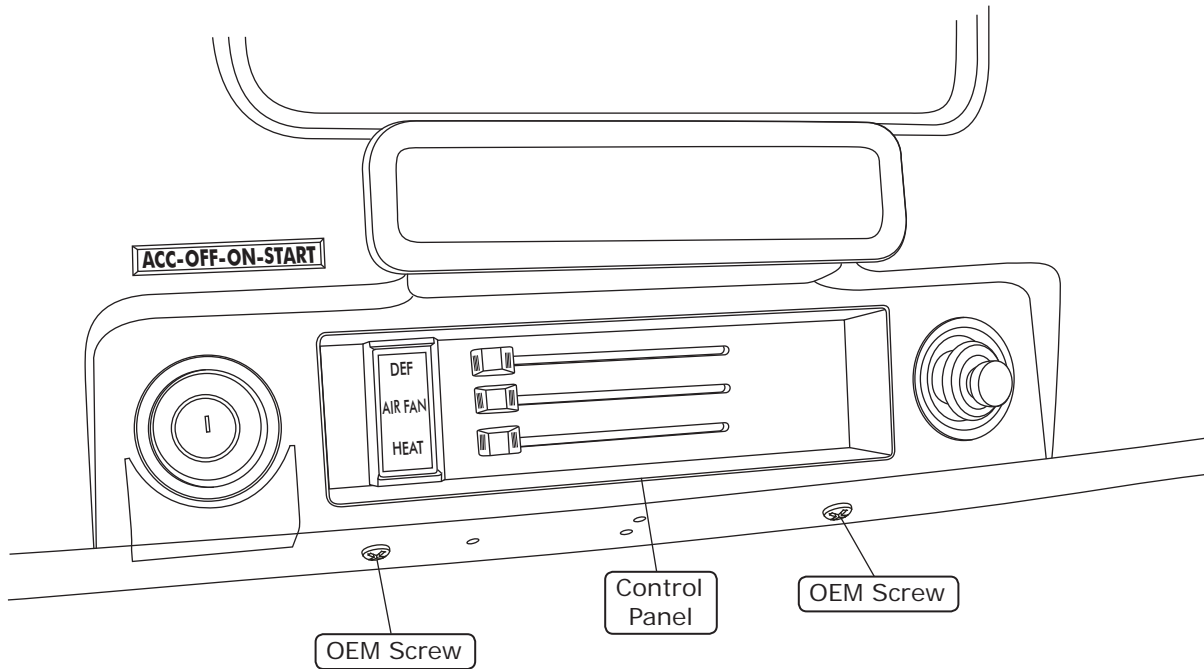

Figure 1



www.vintageair.com

Control Panel Installation

1. From behind the dash, place the control panel against the dash opening (See Figure 1, below).
2. While pressing the bezel firmly into the dash aperture, secure the control panel to the dash using (2) 5/16-18 x 1/2" pan head screws and (2) 5/16-18 hex nuts (See Figure 1, below).
3. Plug the control harness into the back of the control panel as shown in Figure 2, below.
4. Plug the control harness into the ECU module on the sub case as shown in Figure 3, below.

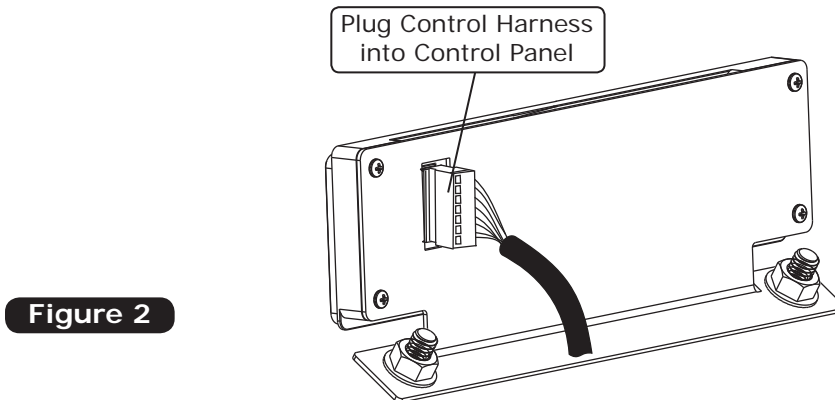
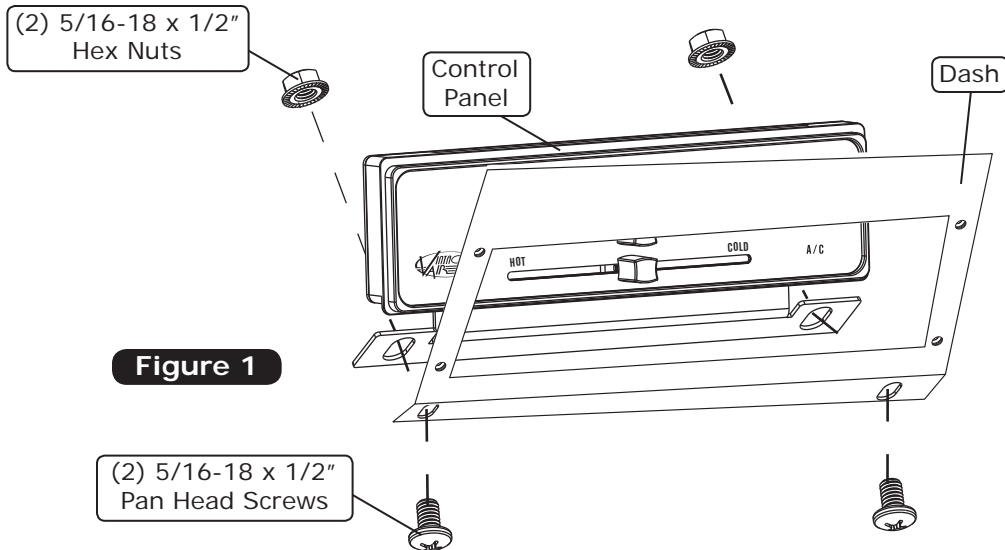

NOTE: When using a Vintage Air supplied control panel, connect the tan wire from the Gen IV Evaporator wiring harness (232600-VUA) to the factory dash lights to enable panel backlighting.

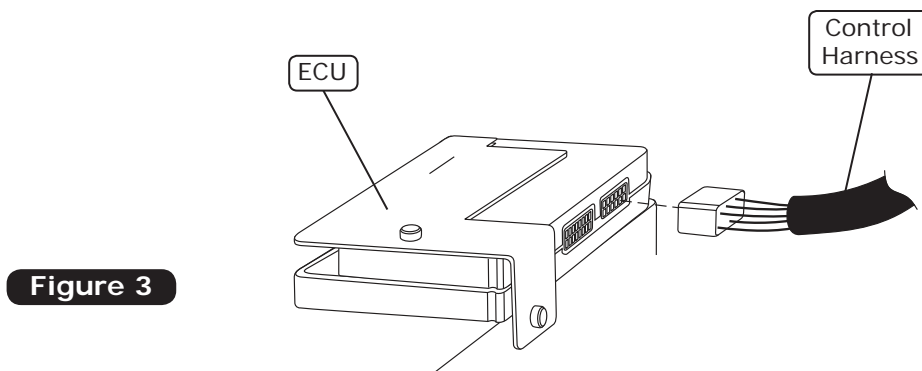



www.vintageair.com

Control Panel Calibration Procedure

On Vintage Air Gen IV systems using factory controls, it is necessary to calibrate the system to your specific control panel. This procedure ensures that the stroke of your control panel levers or knobs is translated into precise control of the fan speed, temperature blend and mode door position. Please carefully read and understand these procedures before beginning. The procedure may be repeated as many times as necessary to get it right.

In preparation for calibration, you will need to attach the supplied white ground jumper wire to a suitable chassis ground. This jumper wire must be easily connected to the gray programming wire located in the main Gen IV wiring harness next to the compressor relay. During the calibration procedure, you will connect the white jumper to the gray program wire, which will "teach" the Gen IV ECU the upper limits of the control levers or knobs. The blower will momentarily change speeds, signaling that the upper limits have been "learned". You will move the levers or knobs to opposite extreme positions of their travel and then disconnect the white jumper. The blower will again change speeds, signaling that the lower limits have been learned and that the calibration procedure is complete.

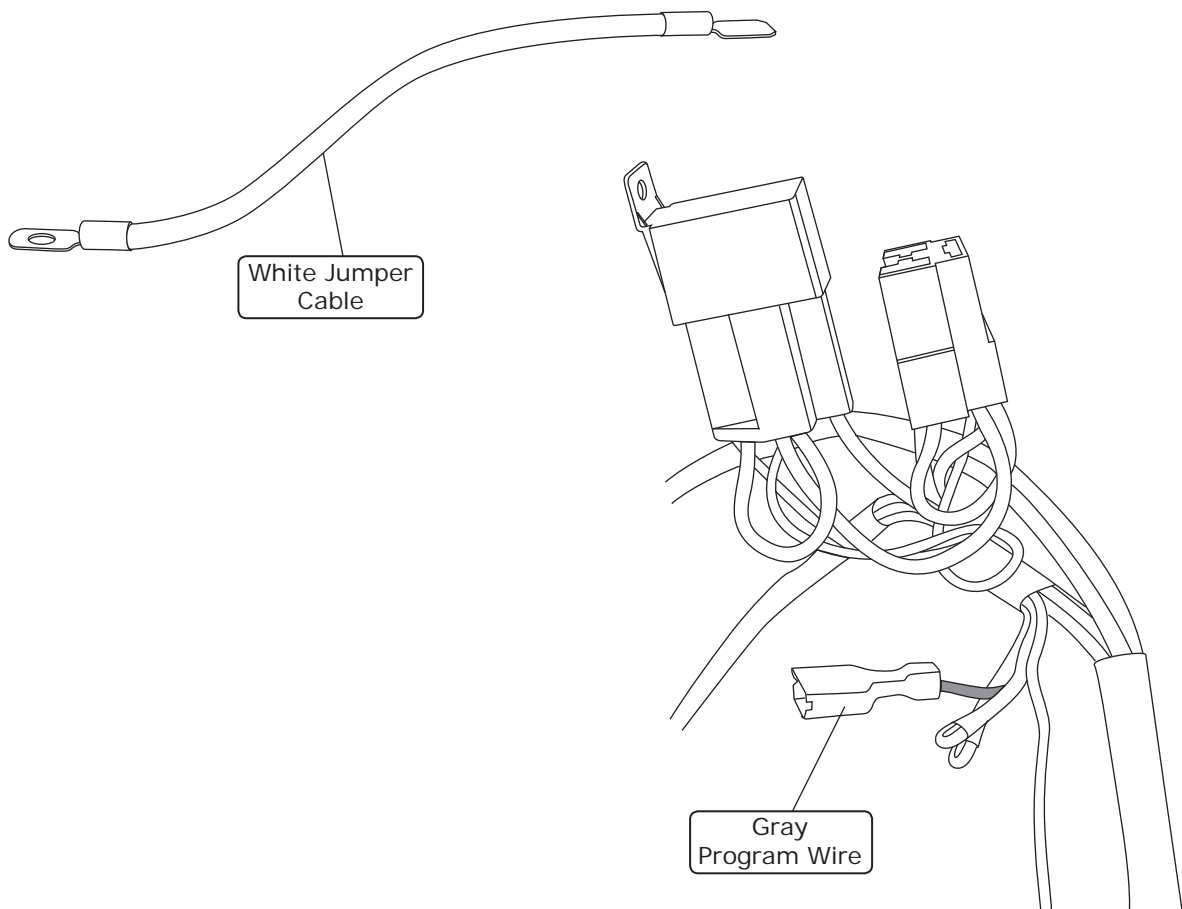



www.vintageair.com

Control Panel Calibration Procedure (Cont.)

1. Turn on the ignition switch (Do not start the engine).

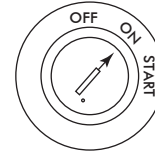

2. Move the control levers/knobs to the positions shown.



3. Connect the white jumper wire to the gray program wire. Wait for the blower speed to change (Approximately 5 seconds).

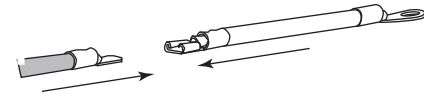

4. Move the control levers/knobs to the positions shown.



5. Disconnect the white jumper wire from the gray program wire. The blower speed will change, indicating completion of the calibration procedure.

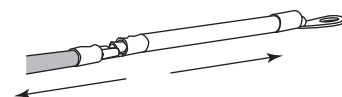

6. Confirm proper operation of controls. Repeat procedure if necessary. When finished, tape over program wire connector with electrical tape to prevent accidental contact with chassis ground.



www.vintageair.com

Wiring Diagram

232007-VUR

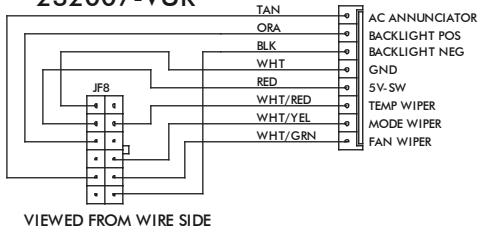

232002-VUA

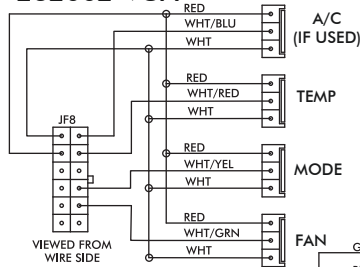

GEN IV ECU

GEN IV WIRING DIAGRAM
REV E, 10/6/2017

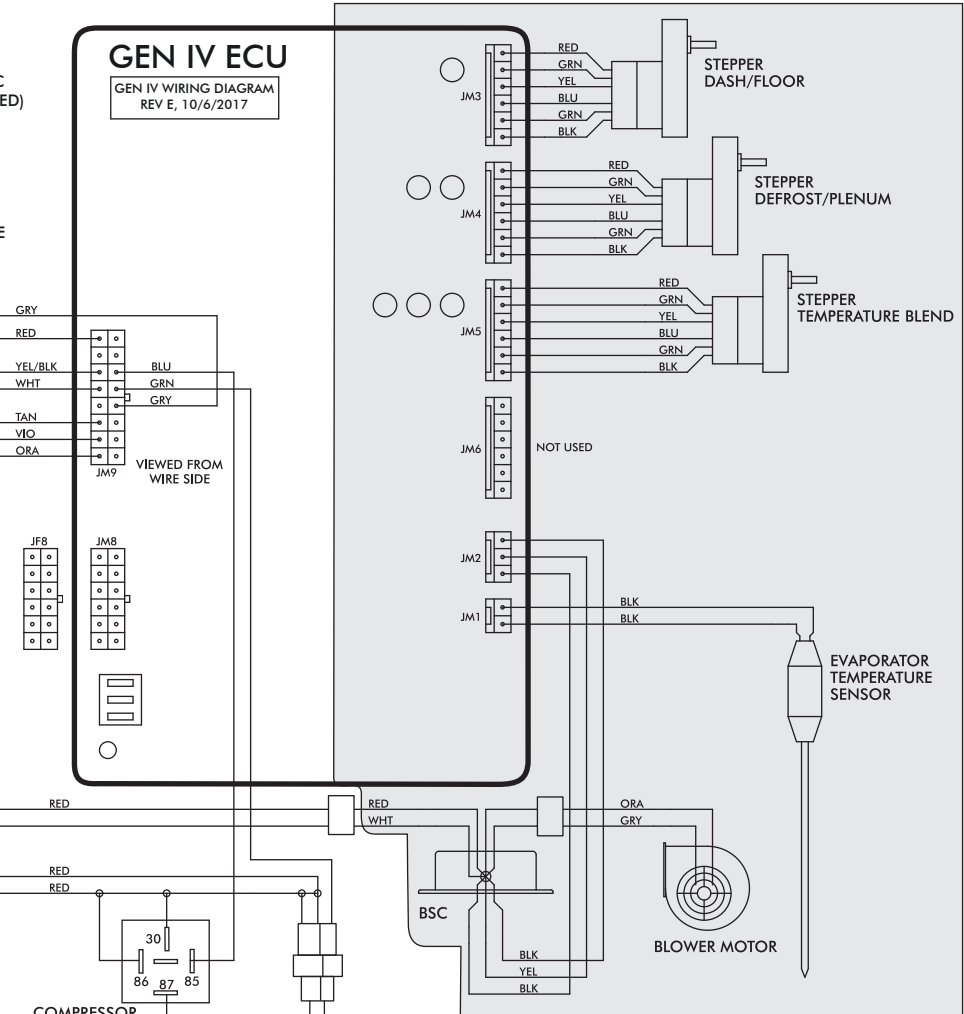

PRE-WIRED

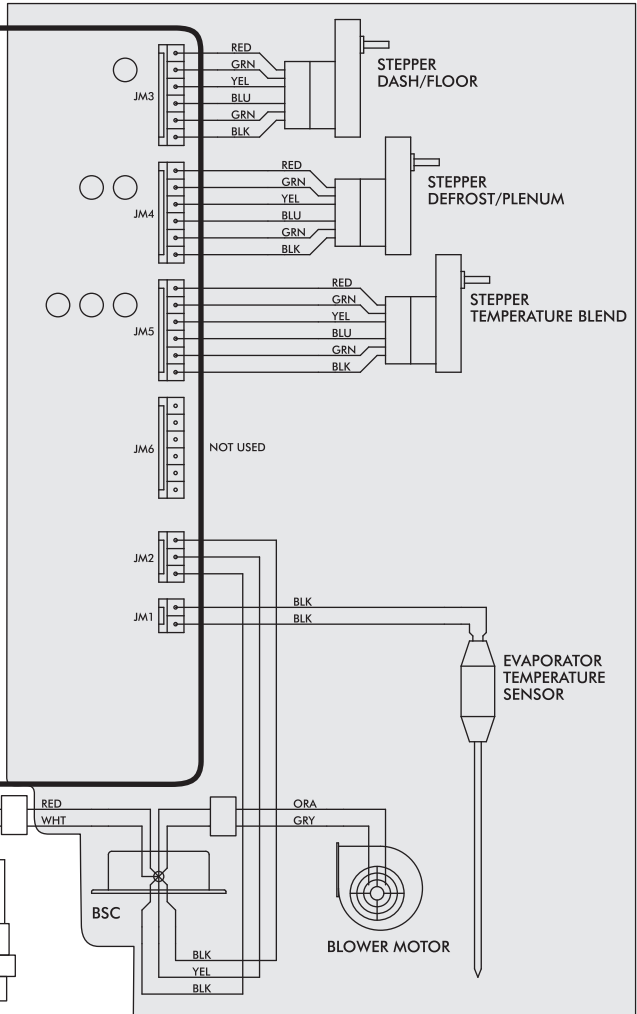

PROGRAM

N/A
* DASH LAMP
(IF USED)
*** WIDE OPEN
THROTTLE SWITCH
(OPTIONAL)

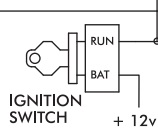

** CIRCUIT
BREAKER
30 AMP

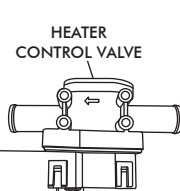

NOTE: = CHASSIS GROUND

* Dash lamp is used only with type 232007-VUR harness.

** Warning: Always mount circuit breaker as close to the battery as possible. (NOTE: Wire between battery and circuit breaker is unprotected and should be carefully routed to avoid a short circuit).

*** Wide open throttle switch contacts close only at full throttle, which disables A/C compressor.



www.vintageair.com

Operation of Controls

On Gen IV systems with three lever/knob controls, the temperature control toggles between heat and A/C operations. To activate A/C, move the temperature lever/knob all the way to cold and then back it off to the desired vent temperature. For heat operation, move the temperature lever/knob all the way to hot and then adjust to the desired vent temperature. The blower will momentarily change speed, each time you toggle between operations, to indicate the change. **NOTE: For proper control panel function, refer to Pages 7 and 8 for calibration procedure.**

Blower Speed

This lever/knob controls blower speed, from OFF to HI.

Mode Control

This lever/knob controls the mode positions, from DASH to FLOOR to DEFROST, with a blend in between.

Temperature Control

This lever/knob controls the temperature, from HOT to COLD.

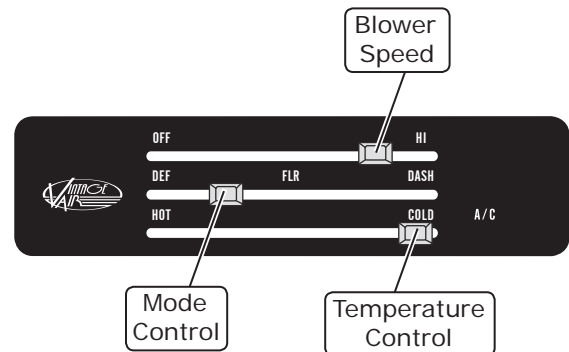

A/C Operation

Blower Speed

Adjust to desired speed.

Mode Control

Adjust to desired mode position (DASH position recommended).

Temperature Control

For A/C operation, adjust to coldest position to engage compressor (Adjust between HOT and COLD to reach desired temperature).



Heat Operation

Blower Speed

Adjust to desired speed.

Mode Control

Adjust to desired mode position (FLOOR position recommended).

Temperature Control

For maximum heating, adjust to hottest position (Adjust between HOT and COLD to reach desired temperature).



Defrost/De-fog Operation

Blower Speed

Adjust to desired speed.

Temperature Control

Adjust to desired temperature.

Mode Control

Adjust to DEFROST position for maximum defrost, or between FLOOR and DEFROST positions for a bi-level blend (Compressor is automatically engaged).





www.vintageair.com

Packing List: (473080) Machined Finish Control Panel

No.	Qty.	Part No.	Description
1.	1	473080	Control Panel Assembly, Machined Finish
2.	1	232007-VUR	Control Harness, Gen IV Universal
3.	2	180031	Nut, 5/16-18, Hex
4.	2	180030	Screw, 5/16-18 x 1/2", Pan Head

Checked By: _____

Packed By: _____

Date: _____

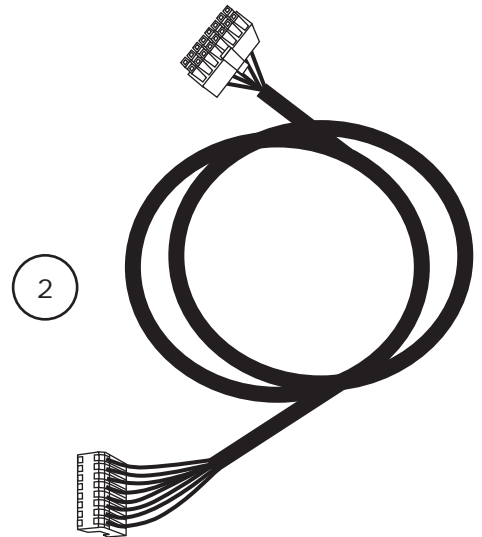
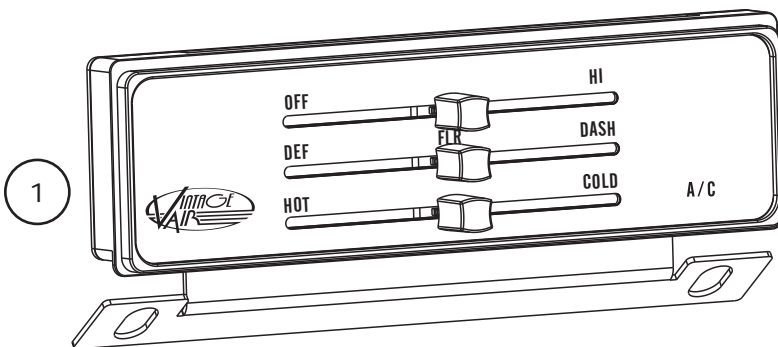

**NOTE: Images may not depict actual parts and quantities.
Refer to packing list for actual parts and quantities.**



www.vintageair.com

Packing List: (473081) Black Anodized Control Panel

No.	Qty.	Part No.	Description
1.	1	473081	Control Panel Assembly, Black Anodized
2.	1	232007-VUR	Control Harness, Gen IV Universal
3.	2	180031	Nut, 5/16-18, Hex
4.	2	180030	Screw, 5/16-18 x 1/2", Pan Head

Checked By: _____
Packed By: _____
Date: _____

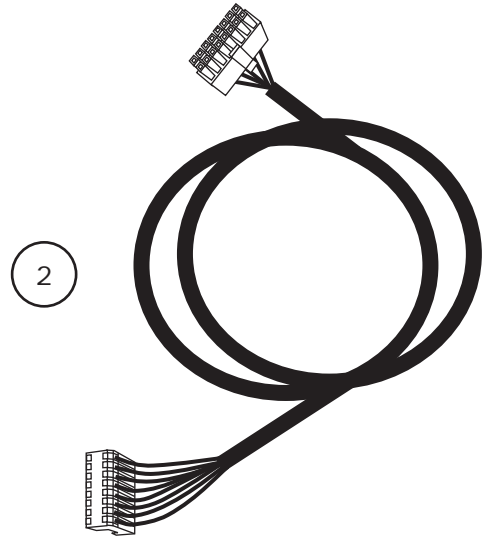
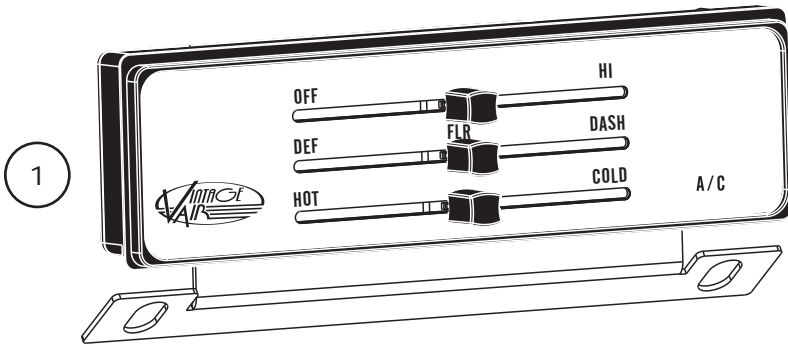

NOTE: Images may not depict actual parts and quantities.
Refer to packing list for actual parts and quantities.