



Steering, Brake & Suspension Specialists

## #CP939U - Sway Bar Installation Instructions

### 1" Rear Sway Bar for 1964-72 Midsize

#### Hardware:

2 RH 608 Plates  
2 RH 400 U-Bolts  
2 RH 213 Bolts  
4 RH 206 Bolts  
8 RH 104 Washers  
4 RH 067 Tubes  
10 RH 304 Lock-Nuts

*NOTE: Some high performance models (GTO, 442, Chevelle SS, etc.) come equipped with rear lower control arms that are boxed in on the bottom. If your car is equipped with these control arms, the #CP939U bar will not fit properly. The #324, which mounts on the bottom of the control arms must be used. Contact your dealer to exchange kits.*

#### Instructions:

1. Remove the original bar, if your car has one. The new bar is double forged and uses a mounting plate, which increases bar strength and stability.
2. Bolt the mounting plates to the bar as shown. Use the U-bolts and two shorter bolts provided.
3. Position bar under your car, arms forward and plates upward. Lift bar so that the plates go into control arms. Slide bar back evenly until the plates wedge in the control arms.
4. Mark the control arms for drilling holes that will align with holes in the plates. (GM supplied many different hole patterns as well as no holes over the years. If any of the holes align with the plate, they may be used). If holes need to be drilled, they should be drilled with a 3/8" drill bit. **FOR YOUR SAFETY ALWAYS USE CAUTION AND WEAR EYE PROTECTION WHEN DRILLING!**
5. Pass the four longer bolts through a washer, control arm, spacer tube, plate, control-arm, washer, and secure with a nut as shown. Tighten all U-bolt nuts to 20 ft/lbs. and all other nuts to 30 ft/lbs.
6. Road-test your car so as to accustom yourself to its new handling. As we cannot supervise your installation (or driving) we cannot be responsible for more than the cost of the kit. **NOTE: For best balance, control, and stability, this kit should be used in conjunction with one of our front kits.**

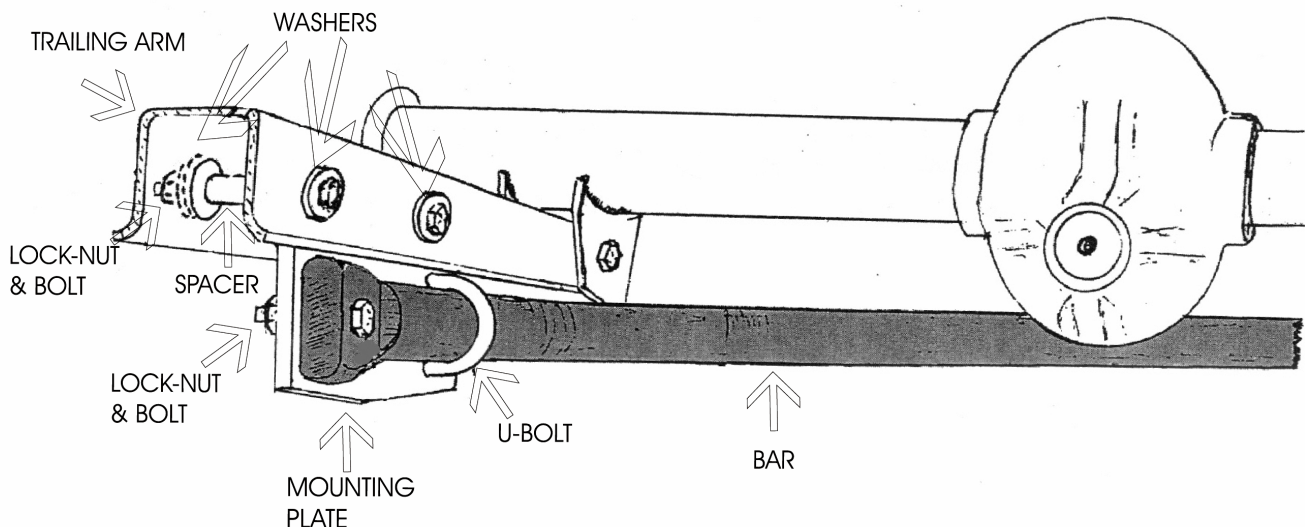

**For technical help call Classic Performance Products Monday thru Friday 8:30am to 5:00pm at (714) 522-2000.**

**Classic Performance Products, Inc. 714.522.2000** | fax 714.522.2500  
175 E. Freedom Avenue | Anaheim, CA 92801 | [www.classicperform.com](http://www.classicperform.com)