



### Part # 11170203 - 1970-1981 GM "F" Body HQ Series CoilOver System

#### Recommended Tools

#### Front Components:

- 11173510 Front CoilOver Instructions
- 11173699 Front Upper Control Arms
- 11172899 Front Lower Control Arms
- 11179120 Front SwayBar Instructions

#### Rear Components:

- 11177187 Rear 4Link System
- 11176510 Rear Coilover Instructions

#### Miscellaneous Components:

- 85000000 Spanner Wrench

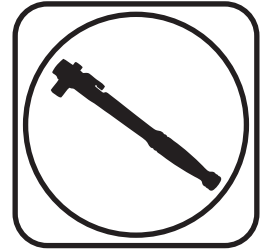

# 1970-1981 GM "F" Body Coilover Installation Instructions

#### Table of contents

- Pages 2-5..... Front CoilOvers
- Pages 6-10..... Upper Control Arms
- Pages 11-14..... Lower Control Arms
- Pages 15-17..... Front MuscleBar
- Pages 18-44..... Rear 4 Link System
- Pages 45-48..... Rear CoilOvers





### Part # 11173510 - 1970-1981 GM "F" Body HQ Front CoilOvers

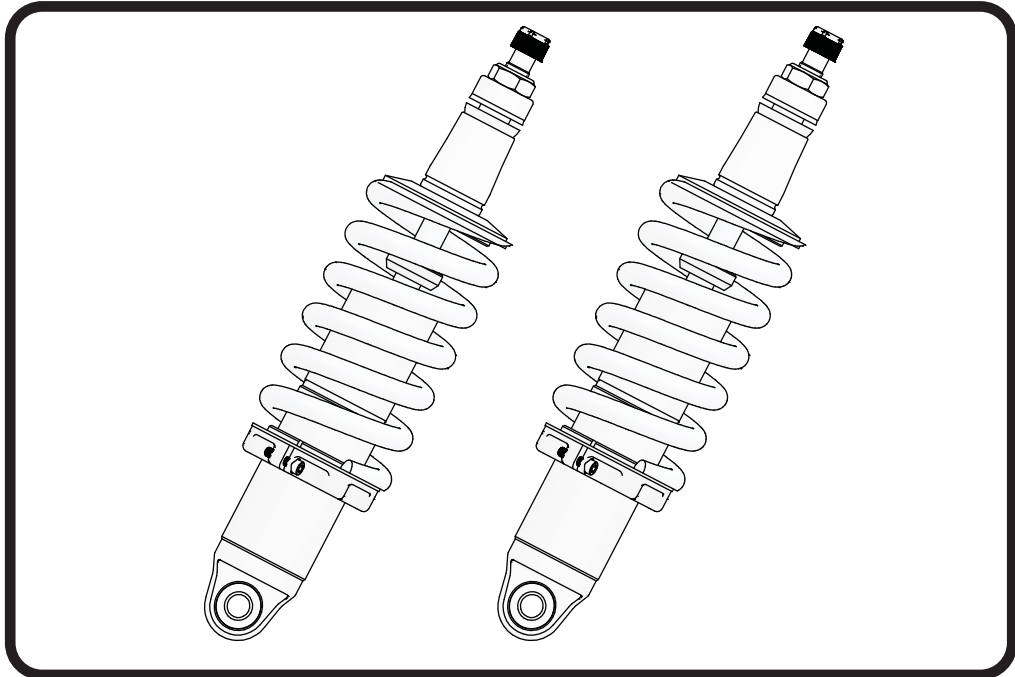

#### Recommended Tools

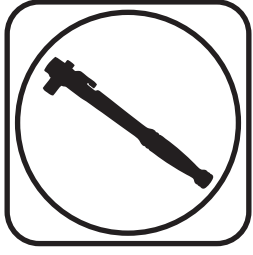

### 1970-1981 GM "F"Body HQ Series Front CoilOvers

# Installation Instructions

Table of contents	
Page 3.....	Included components
Page 4.....	CoilOver Assembly
Page 5.....	CoilOver Installation

ShockWave Dimensions:	
Center of bearing to Stud Mounting Surface:	
Compressed:	10.48"
Ride Height:	12.55"
Extended:	14.08"



### Major Components .....In the box

Item #	Part #	Description	QTY
1	982-10-803	3.6" Stroke HQ Series Shock	2
2	59080700	CoilSpring 8" 700lb	2
3	70010828	Delrin Spring Washer	4
4	803-00-109(kit)	Lower Spring Adjuster Nut (803-00-109 kit)	2
5	803-00-109(kit)	Adjuster Nut Locking Screw (803-00-109 kit)	2
6	803-00-109(kit)	Upper CoilSpring Retaining Plate (803-00-109 kit)	2
7	803-00-109(kit)	CoilSpring Plate Retaining Ring (803-00-109 kit)	2
8	90009989(kit)	2.75" Stud Adjuster Assembly	2
9	90002313	2.75" Stud Top Base	2
10	90001904	Delrin Ball Lower Half	2
11	90001903	Delrin Ball Top Half	2
12	90001902	Delrin Ball Upper Cap	2
13	99562003	9/16-18" Nylok Nut	2
14	210-35-120-0	Shock Adjuster Knob	2
15	90009969	Adjuster Knob Retaining Screw	2
	90001994	5/8" ID Bearing (installed in shock body)	2
	90001995	Bearing Snap Ring (installed in shock body)	4

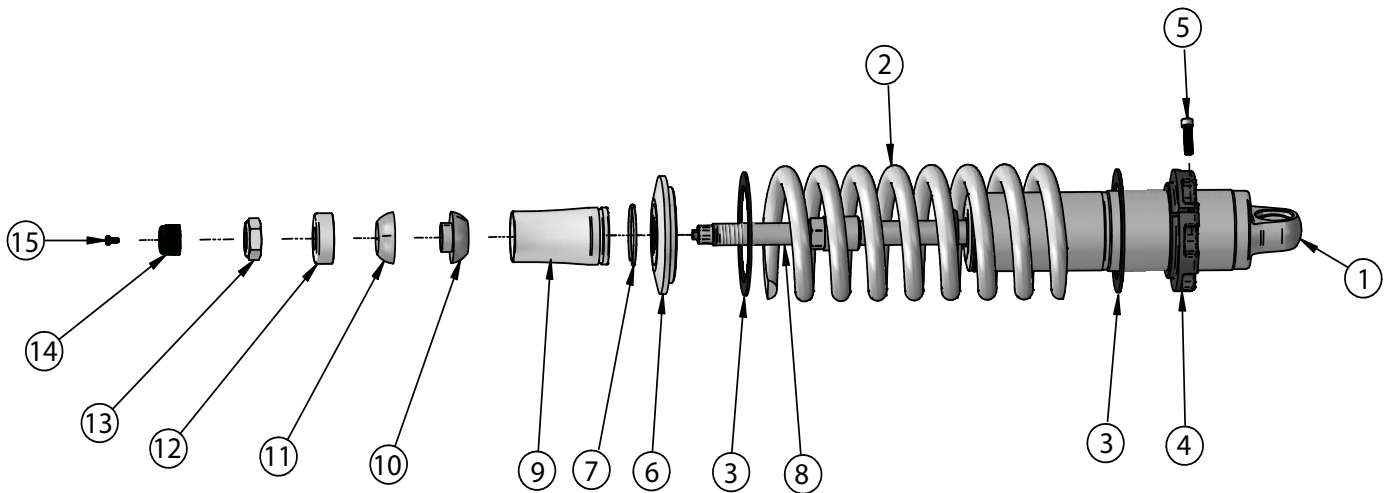

**BEARING SPACERS (90002062) ARE INCLUDED WITH THE FRONT LOWER CONTROL ARMS**



### CoilOver Assembly

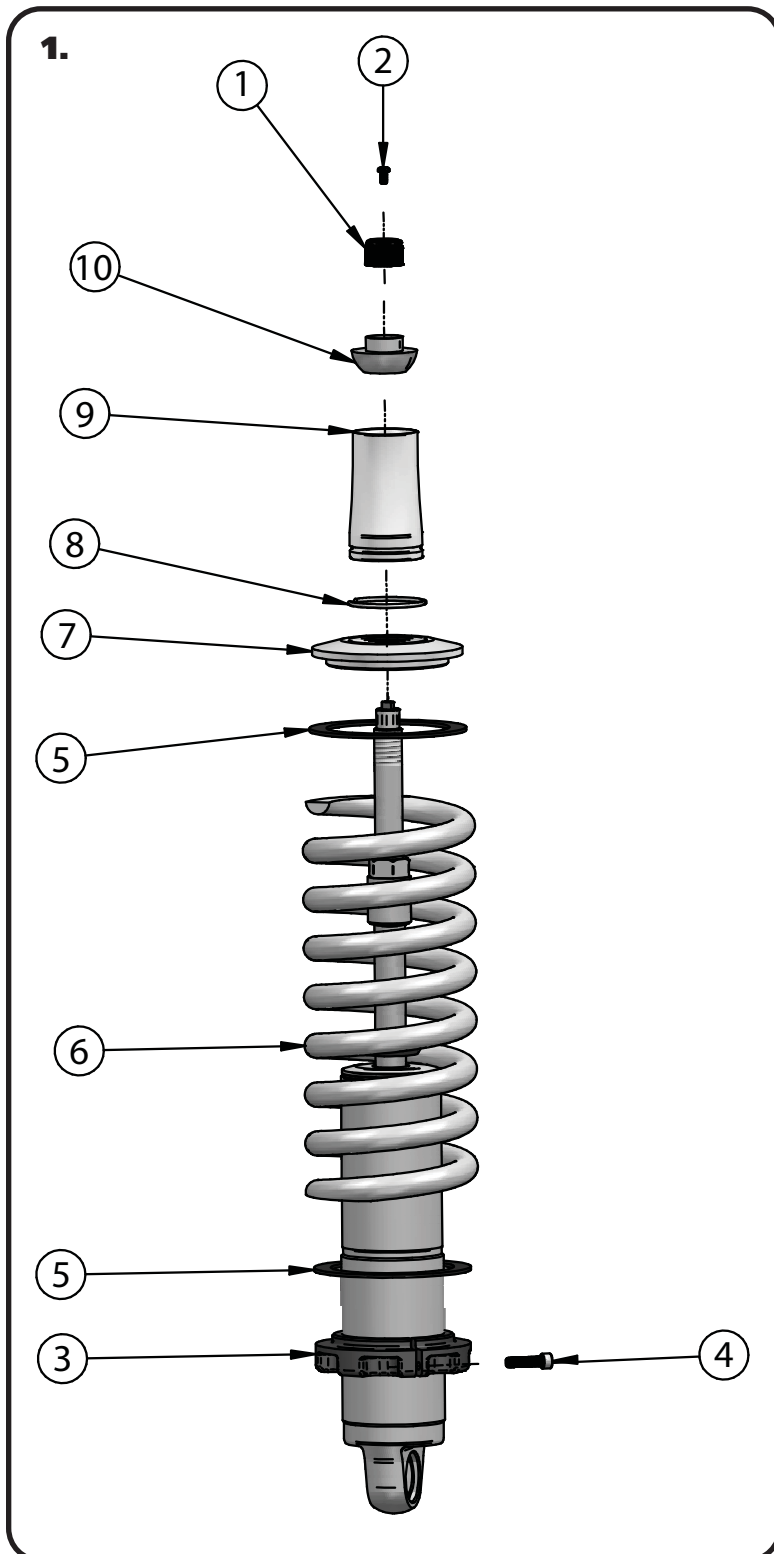

- 1.** To Assemble the CoilOver you need to:
  - a.** Remove Screw (2) from center of Adjustment Knob (1) and remove Adjustment Knob.
  - b.** Remove Nylok Nut, Delrin Upper Cap, Delrin Upper and Lower Balls, along with the base from the Coliover stud.
  - c.** Thread Adjuster Nut (3) onto the CoilOver body. Once it is threaded on the shock body, lightly thread in the locking screw (4) into the Adjuster Nut.
  - d.** Install a Delrin Spring Washer (5) onto the Adjuster Nut.
  - e.** Slide the CoilSpring (6) onto the CoilOver.
  - f.** Install another Delrin Spring Washer (5) on top of the CoilSpring.
  - g.** Install the Upper CoilSpring Plate (7) onto the CoilSpring.
  - h.** Install the CoilSpring Retaining Ring (8) onto the Stud Top Base (9). It fits into the groove in the base.
  - i.** Slide the Stud Top Base onto the shock until it bottoms out on the stud. It may be necessary to thread the Adjuster Nut down the shock body (to lower the spring) if the base will not slide all the way down onto the stud.
  - k.** Slide the Lower Delrin Ball (10) (it has the collar sticking up around the center hole) on to the Stud Top.

Repeat on second CoilOver.



### CoilOver Installation

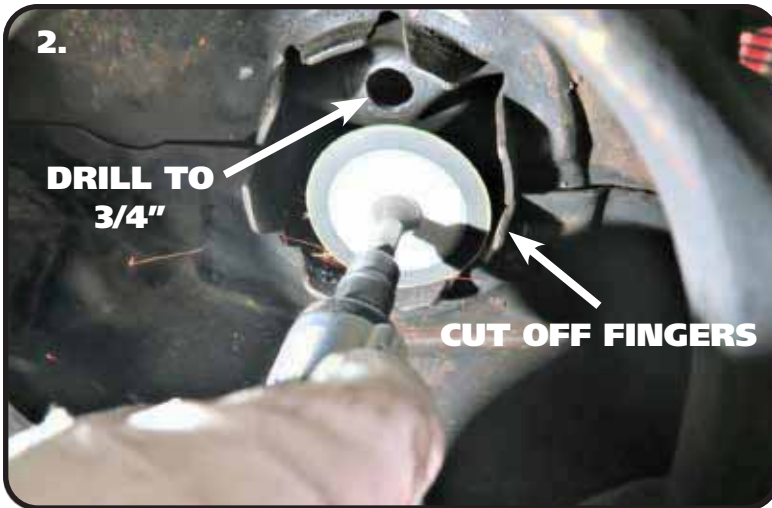

2. Drill the OEM shock hole out to 3/4". This can be done with a Unibit. The CoilOver top will come in contact with the coil spring retaining fingers, they must be cut off. A die grinder works well here.

**Note:** It may be helpful to go ahead and install the lower StrongArms and CoilOvers to determine exactly what needs to be removed.

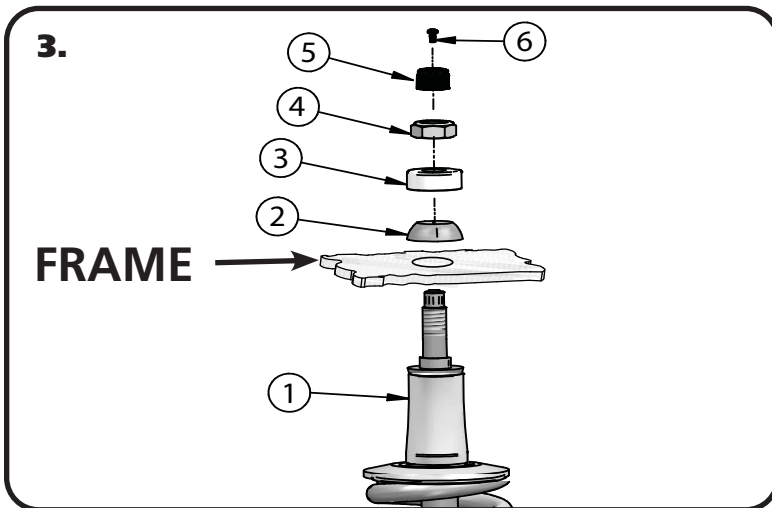

3. With the CoilOver(1) assembled, it is time to bolt them into the car. **The factory shock hole will need to be drilled out to 3/4", this can best be done using a Unibit.** Insert to CoilOver Stud Top through the factory hole in the frame. Install the Upper Delrin Ball(2) onto the shock stud with the flat side facing the frame. Next, Install the Delrin Ball cap (3) onto the shock stud with the Concave side facing the Upper Delrin ball. Install the Nylok Nut(3) onto the shock stud and lightly tighten. The needs to be some resistance on the ball but not tight enough that it will not rotate freely. Reinstall the adjuster knob(5) using the screw (6) that was removed during step 1.

**TIGHTENING THE TOP 9/16"-18 NUT:** SNUG THE NUT DOWN AGAINST THE TOP CAP. YOU NEED TO BE ABLE TO ARTICULATE THE SHOCK BY HAND. WE TORQUE THE NUT TO 80 INLBS USING A 7/8" CROWS FOOT WRENCH ON A TORQUE WRENCH.

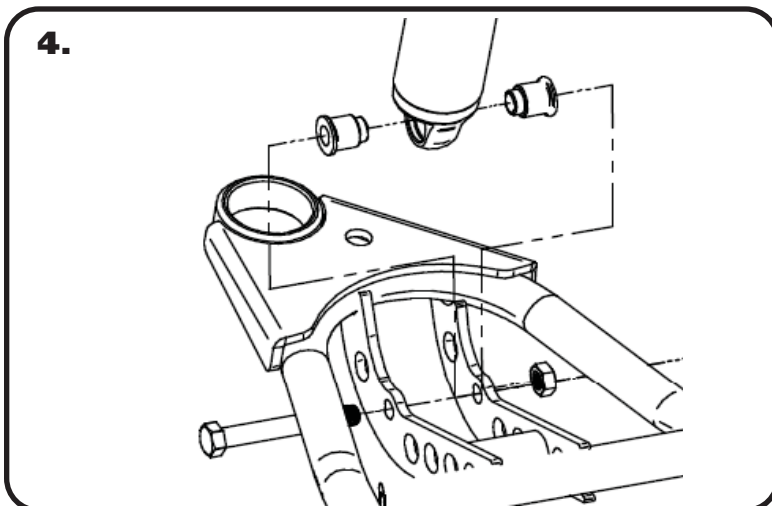

4. Install a spacer on each side of the lower Coilover. Slide the shock with the spacers installed into the lower control arm. Raise the arm up to line up the holes in the bushing with the 1/2" hole in the control arm straps and hold it in place while you install the 1/2" x 3 1/2" bolt, 1/2" flat washer, and 1/2" Nylok nut. Tighten the upper and lower shock bolts.



### Part # 11173699 - 1970-1981 GM F-Body Front Upper StrongArms



#### Recommended Tools

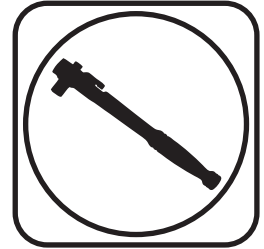

## 1970-1981 GM F-Body Upper StrongArms Installation Instructions

Table of contents	
Page 7.....	Included Components
Page 8.....	Getting Started & Installation
Page 9.....	Offset Upper Control Arm Shaft
Page 10.....	Installation & The Finish



### Upper Control Arm Components ....In the box

Item #	Part Number	Description	QTY
1	90003493	Driver Upper Control Arm ( <b>Shown</b> )	1
2	90003494	Passenger Upper Control Arm	1
3	90000913	Tall Upper Balljoint Assembly - Proforged # 101-10020	2
4	90000917	Upper Cross Shaft Kit - includes nuts and washers	2
5	90001442	Delrin Control Arm Bushing	4
6	90003385	Delrin Bushing Inner Sleeve	4
7	70013323	Bump Stop	2
8	99373003	3/8" SAE Flat Washer	2
9	99372002	3/8" -16 Nylok Nut	2

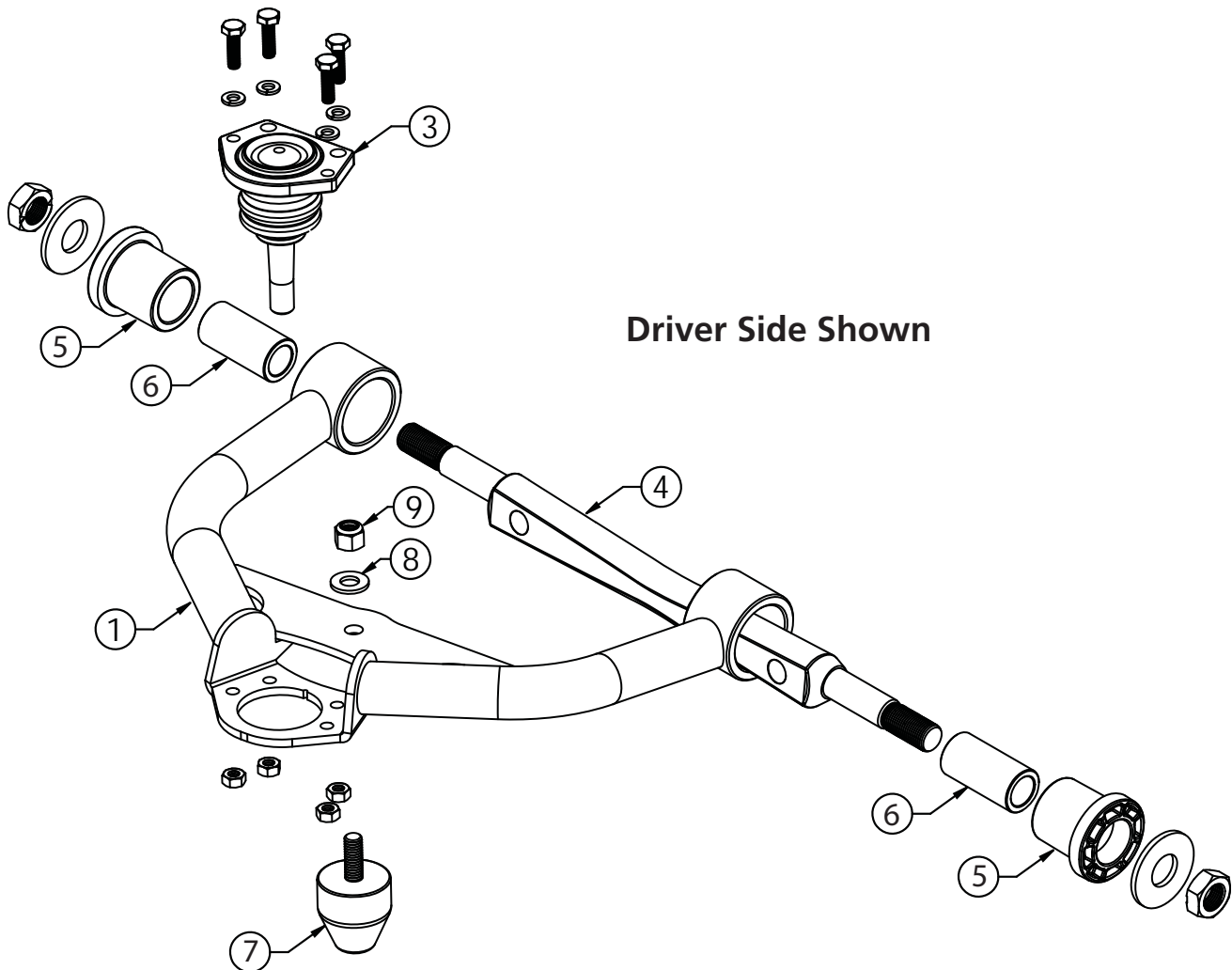



### Getting Started.....

Congratulations on your purchase of the Ridetech F-Body StrongArms. These StrongArms have been designed to give your F-Body excellent handling along with a lifetime of enjoyment. Some of the key features of the StrongArms: Ball Joint angles have been optimized for the lowered ride height, Delrin bushings are used to eliminate bushing deflection along with providing free suspension movement through the entire travel. The Geometry has been optimized for excellent handling and driveability. The Delrin bushings are made from a material that is self lubricating so no grease zerks are needed.

**The cross shaft washers and nuts will need to be installed on the cross shaft. When assembling the Control Arms tighten the cross shaft nuts enough to create drag on the delrin bushings, the arm should still move through its travel by hand.**

### Installation

1. Remove the entire upper control arms from the car. If you are replacing the lower control arms and spindle, remove them too. Refer to a Factory Service Manual for the proper method.

2.

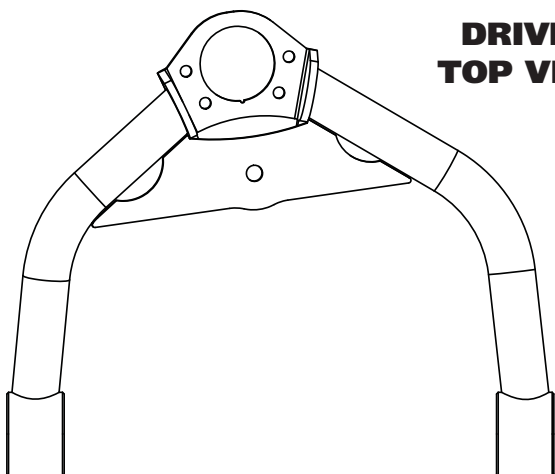

**DRIVER  
TOP VIEW**

2. The Upper Control Arm is attached to the factory mount using factory hardware. Torque the nuts to 50 ft-lbs. The driver side arm is shown in **Figure "2"**. The ball joint located on the arm to the rear of the car.

3.

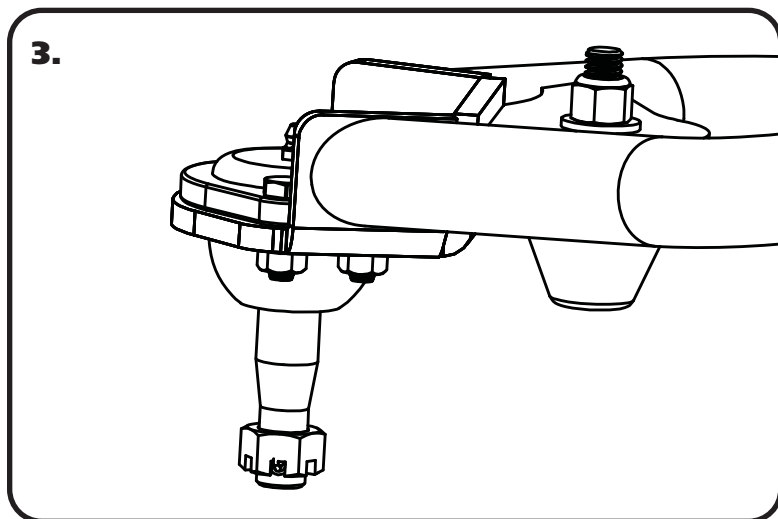

3. Install the Ball Joints in the control arms using **Figure "3"** as a reference. Torque the hardware to 10 ftlbs





### Offset Upper Control Arm Shaft

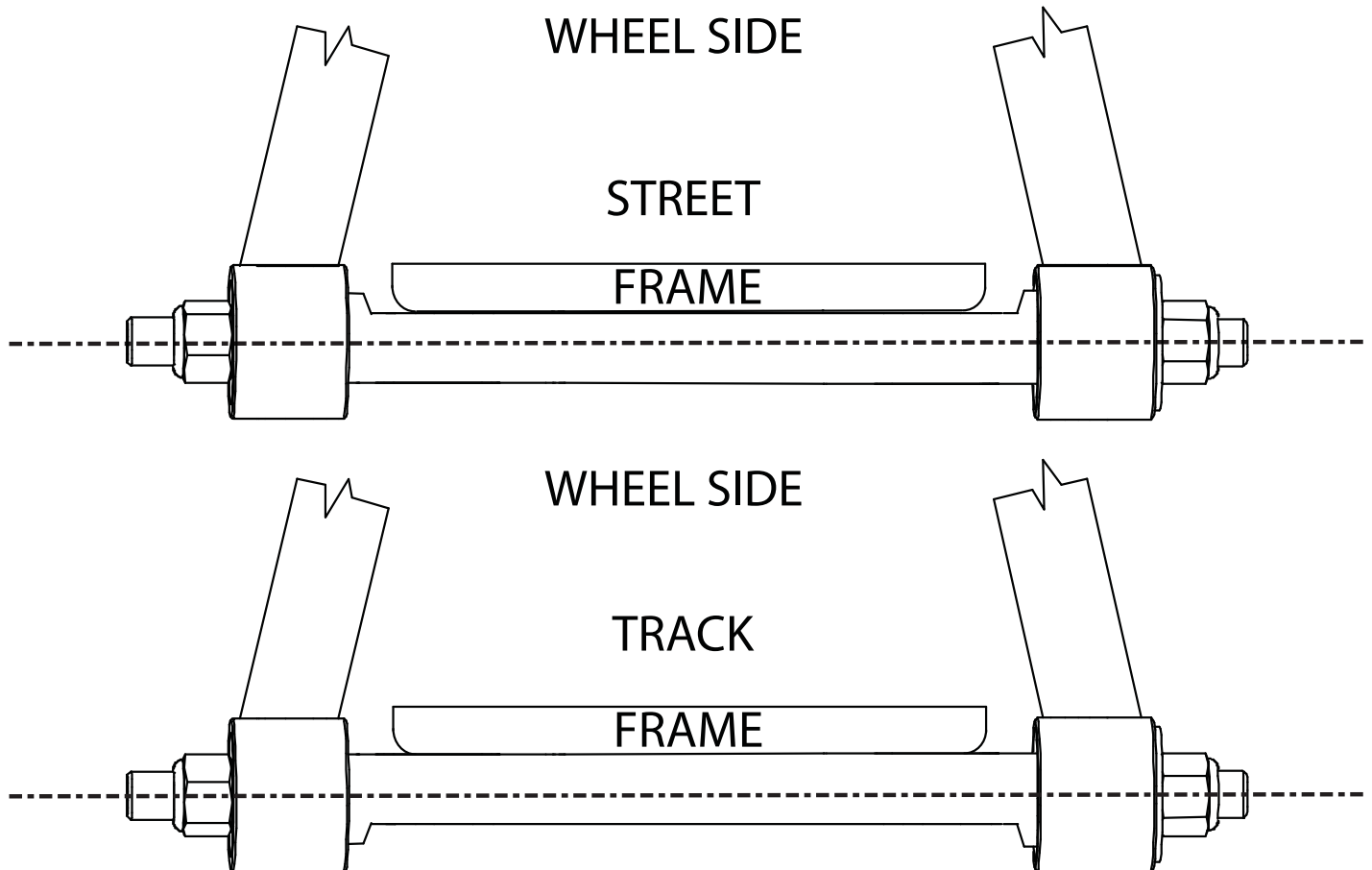

The cross shaft that is used in the upper control arms is offset. The offset allows you to achieve the alignment setting you desire with minimal shims. To change the direction of the offset, simply spin the cross shaft in the control arm.

If you are after a **Street Alignment** bolt the upper control arm to the frame mount with the arm offset to the outside of the car.

If a more aggressive **Track or Autocross** alignment is desired, bolt the control arm to the frame bracket with the arm offset to the inside of the car.



### Installing Upper Control Arms

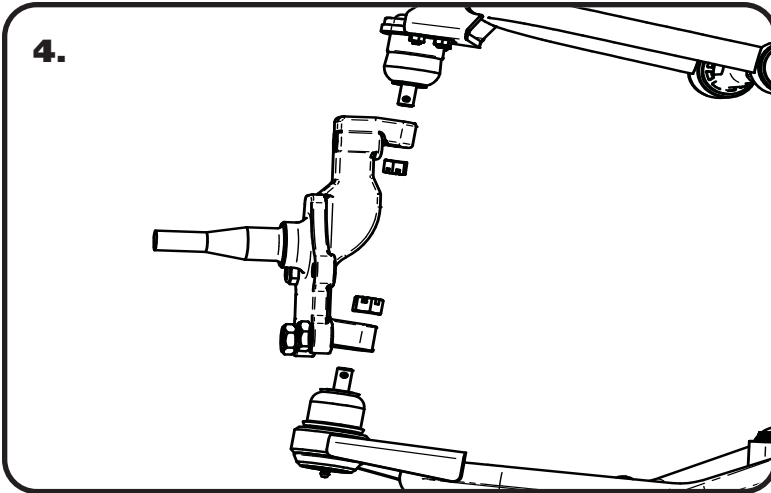

4. Attach the Spindle to the control arms. The steering arm of the spindle will go to the front of the car.

#### Torque Specs:

Lower Balljoint - 65 ftlbs and tighten to line up cotter pin.

Upper Balljoint - 50 ftlbs and tighten to line up cotter pin.

### The Finish

5. Tighten all fasteners. If you are going to install the Ridetech MuscleBar, now is a good time to do it.

**When assembling the Control Arms tighten the cross shaft nuts enough to create drag on the delrin bushings, the arm should still move through its travel by hand.**

#### Suggested Alignment Specs:

Camber: Street: -.5 degrees  
Caster: Street: +3.0 to + 5.0 degrees  
Toe: Street: 1/16" to 1/8" toe in



### Part # 11172899 - 1970-1981 GM F-Body Lower StrongArms



#### Recommended Tools

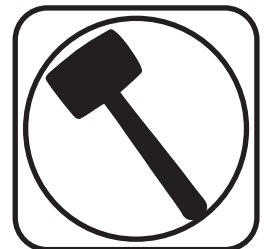
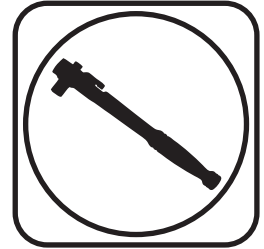

## 1970-1981 GM F-Body Lower StrongArms Installation Instructions

### Table of contents

- Page 12..... Included Components
- Page 13..... Getting Started & Installation
- Page 14..... The Finish



### Lower Control Arm Components .....In the box

Item #	Part Number	Description	QTY
1	90003495	Driver Lower Control Arm <b>(Shown)</b>	1
1	90003496	Passenger Lower Control Arm	1
2	90000896	Lower Ball joint Assembly - Proforged # 101-10049	2
3	70010759	Delrin Bushing - with 2" Diameter Ledge	8
4	90000516	1/2" ID Inner Sleeve - installed in control arms	4
5	90002062	CoilOver Bearing Spacers	4
6	90000517	9/16" ID Inner Sleeve	4

Driver Side Shown

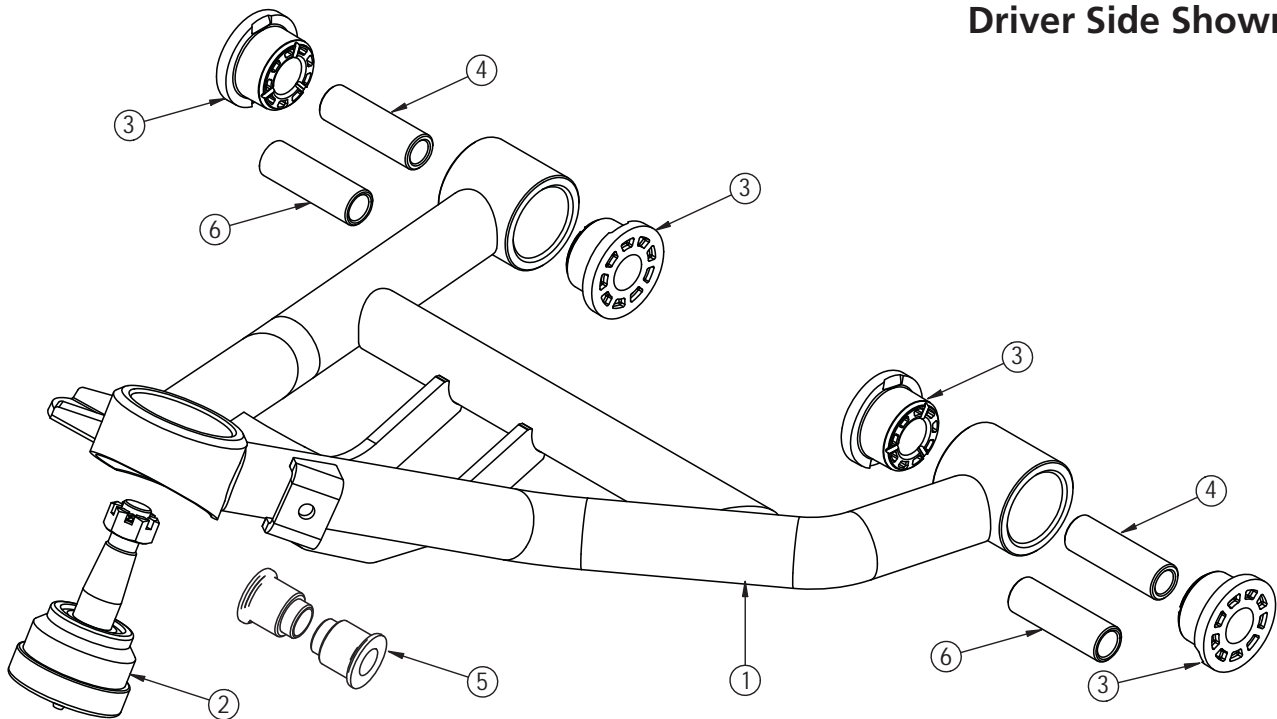

#### Hardware Kit #99010144

Item #	Part Number	Description	QTY
6	99501005	1/2"-13 x 3 1/2" Hex Bolt	6
7	99502009	1/2"-13 Nylok Nut	6
8	99503014	1/2" SAE Flat Washer	10
6	99561010	9/16"-12 x 3 1/2" Hex Bolt	4
7	99562006	9/16"-12 Nylok Nut	4
8	99563003	9/16" SAE Flat Washer	8



### Getting Started.....

Congratulations on your purchase of the Ridetech F-Body StrongArms. These StrongArms have been designed to give your F-Body excellent handling along with a lifetime of enjoyment. Some of the key features of the StrongArms: Ball joint angles have been optimized for the lowered ride height, Delrin bushings are used to eliminate bushing deflection along with providing free suspension movement through the entire travel. The Delrin bushings are made from a material that is self lubricating so no grease zerks are needed.

**Note:** These control arms are designed for use with the Ridetech CoilOvers or ShockWaves. **The factory shocks and springs will not fit these arms.**

### Installation

1. Remove the entire lower control arms from the car. If you are replacing the upper control arms and spindle, remove them too. Refer to a Factory Service Manual for the proper method.
2. Drill the factory upper shock mounting hole to 3/4". This can be done easily with a Unibit.

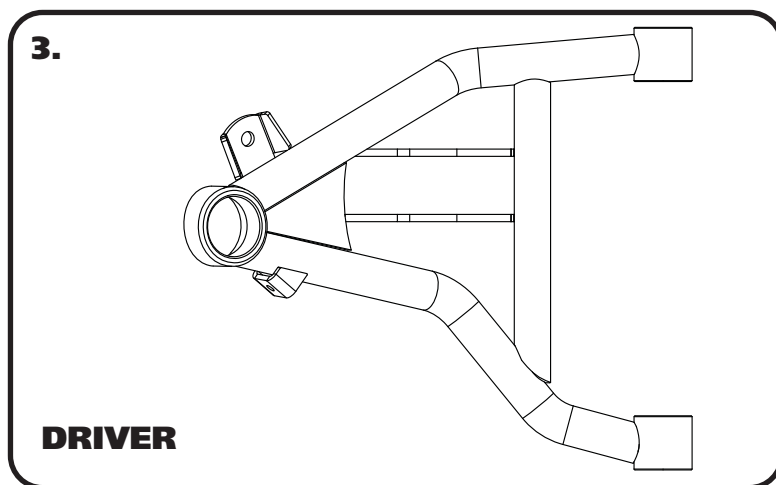

3. After removing the factory lower control arm, clean the bushing mounting surfaces on the frame. The control arms are marked "D" for driver and "P" for passenger. The ball joint pin points up and the Sway bar mount is on the front side of the arm. Fasten the lower arm to the frame with the hardware supplied. There are two different size bushing sleeves supplied 1/2" and 9/16". '71-'74 model years will use 1/2". '75-'81 will use 9/16". Torque to 75 ft-lbs.

Note: On some cars the frame brackets may be pinched and will need to be spread back apart to allow the bushing to slide in.

**Install the CoilOvers at this time. Refer to the CoilOver instructions for assembly.**

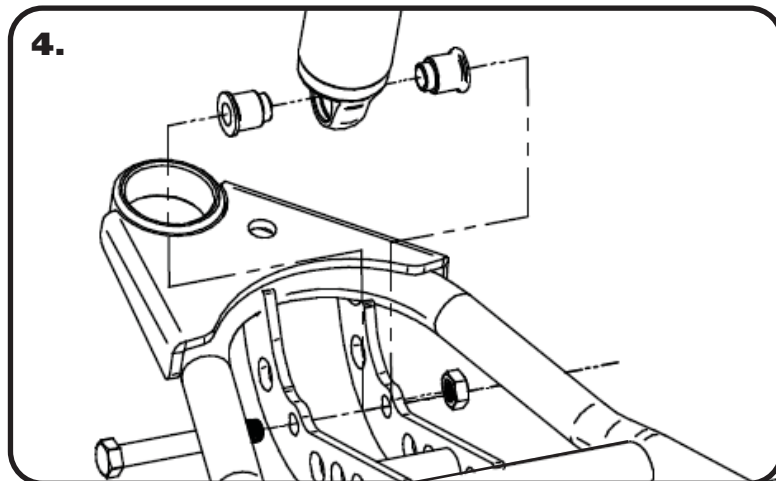

4. Insert the bearing spacers into the lower shock bearing. The SMALL end goes into the bearing. Swing the control arm up, line up the 1/2" holes with the bearing spacers, insert 1/2"-20 x 3 1/2" bolt. Install a 1/2" flat washer and nylok nut. Torque to 75 ft-lbs.



### Installation

5.

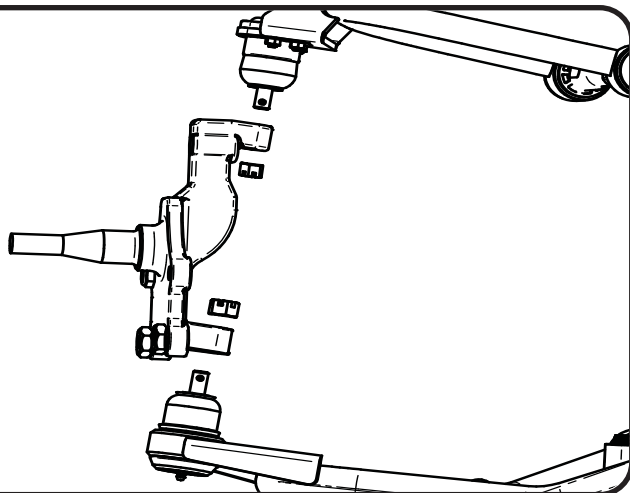

5. Attach the spindle to the control arms. The steering arm of the spindle will go to the front of the car.

#### Torque Specs:

Lower Balljoint - 65 ftlbs and tighten to line up cotter pin.

Upper Balljoint - 50 ftlbs and tighten to line up cotter pin.

### Finishing

6. Tighten all fasteners. If you are going to install the Ridetech MuscleBar, now is a good time to do it.

#### Suggested Alignment Specs:

Camber: Street: -.5 degrees

Caster: Street: +3.0 to + 5.0 degrees

Toe: Street: 1/16" to 1/8" toe in



**Part # 11179120 - 1970-1981 GM F-Body Front SwayBar**

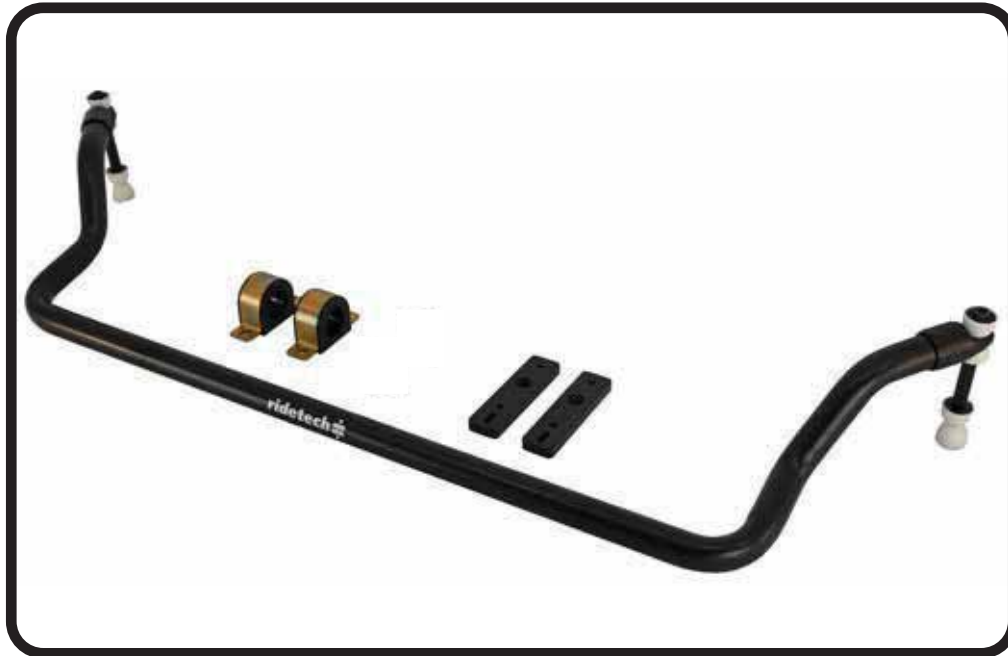

**Recommended Tools**

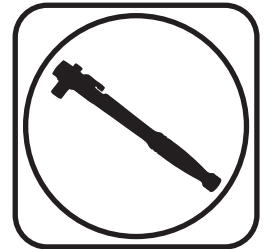

# 1970-1981 GM F-Body Front SwayBar Installation Instructions

**Table of contents**  
Page 16..... Included Components and Hardware List  
Page 17..... SwayBar Installation

**Hardware Torque Specifications**

5/16"-16.....	17 ftlbs
3/8"-16.....	30 ftlbs

# Major Components .....In the box

Part #	Description	QTY
90001226	Front Sway Bar	1
90002936	End Link Kit	1
90001346	Bushing Strap	2
70015015	Lined Sway Bar Bushing	2
90001254	Bushing Mount Adapter	2

## HARDWARE KIT .....99010083

QTY	Part Number	Description
<b>ADAPTER PLATE</b>		
2	99371032	3/8"-16 x 1 1/4" Flat Head
2	99311025	5/16"-18 x 1 1/4" Flat Head
2	99371005	3/8"-16 x 1 1/4" Hex Bolt
2	99311011	5/16"-18 x 1 1/4" Hex Bolt
2	99373002	3/8" Flat Washer
2	99313001	5/16" SAE Flat Washer
2	99373006	3/8" Split Lock Washer
2	99313003	5/16" Split Lock Washer
1	90002263	Red Loctite

QTY	Part Number	Description
<b>BUSHING STRAP</b>		
4	99371065	3/8"-16 x 3/4" Hex Bolt
4	99373002	3/8" Flat Washer
4	99373006	3/8" Split Lock Washer

## Getting Started.....

**Note:** This sway bar kit utilizes a anti-friction lining in the sway bar bushing. The lining allows the sway bar to move freely and quietly in the bushing. No lubrication is required.

**Note:** The threaded holes in the frame can be either 5/16"-18 or 3/8"-16. Hardware is supplied for both.

1. Jack the vehicle up to a safe working height and support with jack stands. Make sure the jack stands are stable before working under the car.
2. Remove the stock sway bar.
3. After removing the stock sway bar, determine what size hardware the frame will require.



**4.** Open the sway bar bushing at the split and slip it **OVER** the sway bar. Do this for both bushings.



**6.** Slip the Bushing Straps over the Sway Bar Bushings.





6.

OEM  
MOUNTING  
HOLES

6. This kit contains an adapter plate to attach the sway bar to the frame. Depending on the year of the car, the hardware size can vary. Before continuing to the next step, you will need to determine the bolt size required for your installation. The threaded holes in the frame can be either 5/16"-18 or 3/8"-16. Hardware is supplied for both.



7.

FRONT

FLAT HEAD  
SOCKET CAP  
SCREW

7. Hold the Frame Plate up to the OEM holes, the Counter Sunk hole will be positioned over the front hole with the slot to the rear. Apply Red Loctite to the Flat Head Bolt. The rear 1 1/4" long bolt uses a Split Washer and Flat Washer. Torque Hardware.



8.

8. Slide the SwayBar into position on the car with the SwayBar arms above the tie rods. Install a 3/8" Lock Washer & 3/8" Flat Washer on the 3/8"x 3/4" Hex Bolts. Do **NOT** Complete tighten the Hardware, it will be left partially loose until the End Links are installed.

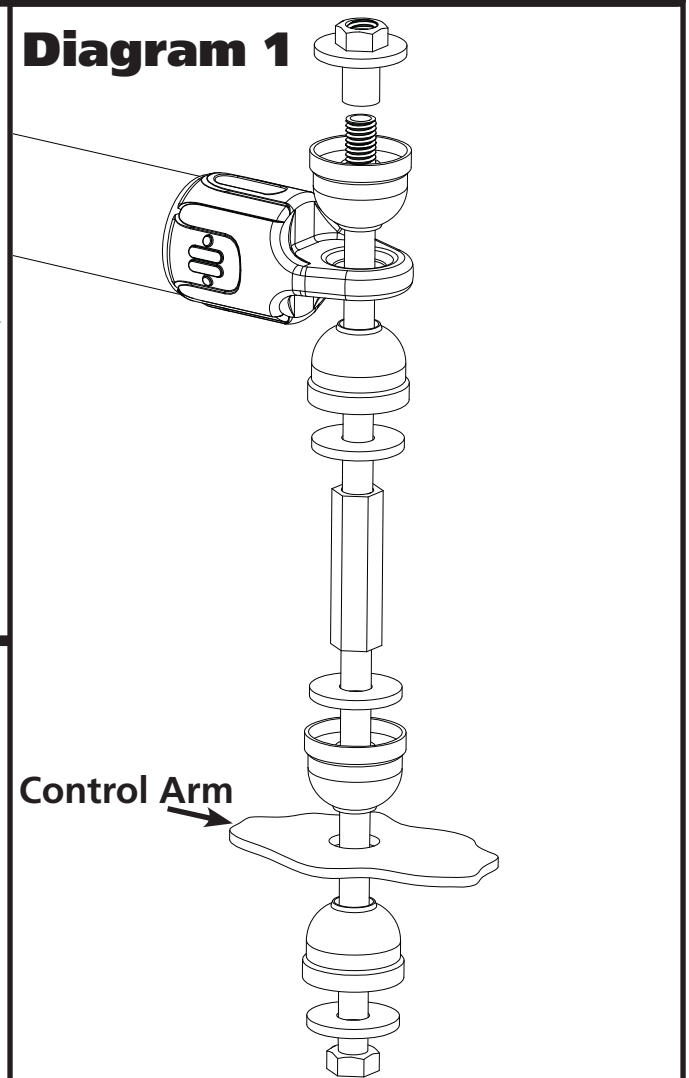

Diagram 1

Control Arm



9

9. Install the End Links using **Diagram 1** as a reference. Install both end links before tightening the end link hardware. Tighten the end link barrel nut until it is flush with the end of the bolt, and then tighten it 2 more complete rounds.

10. Torque the SwayBar mounting hardware to 30 ftlbs.



### Part # 11177187 -1970-1981 GM "F" Body Rear Bolt-in 4 Link

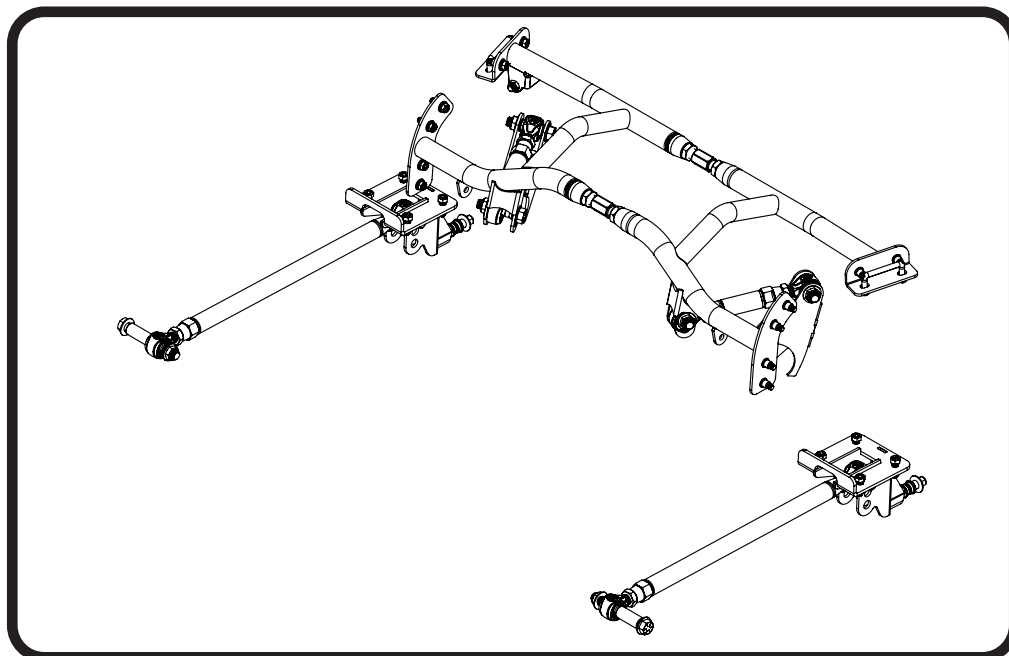

#### Recommended Tools

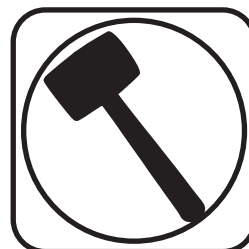
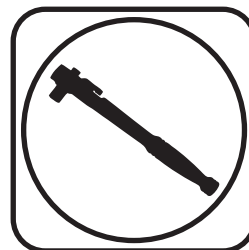
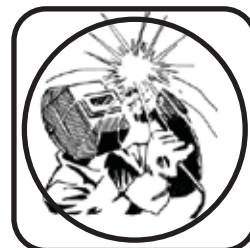

## 1970-1981 GM "F" Body Rear Bolt-in 4-Link Installation Instructions

#### Table of contents

Page 19-20.....	Included Components
Page 21.....	Hardware List & Getting Started
Page 22-23.....	Disassembly
Page 23-25.....	Cradle Assembly
Page 26.....	R-Joint Bar Assembly
Page 27-32.....	Cradle Installation
Page 33-34.....	Installing Lower 4 Link Bars
Page 34.....	Installing Lower Axle Mounts
Page 35.....	Installing Lower Shock Mount
Page 35-36 .....	Installing Lower 4 Link Bars
Page 37 .....	Setting Pinion Angle
Page 38-40.....	Upper Bar Tab Installation
Page 40-41.....	Installing Upper 4 Link Bars
Page 42.....	Installing Lower Shock Stud
Page 43.....	Installing ShockWaves/CoilOvers
Page 44.....	Anti Squat Adjustment





### Major Components .....In the box

Item #	Part #	Description	QTY
1	90003497	70-81 F-Body Rear Cradle - Driver	1
2	90003498	70-81 F-Body Rear Cradle - Passenger	1
3	70015662	Cradle Threaded Adjuster	2
4	70016351	Upper Axle Tab - Inner	2
5	70016352	Upper Axle Tab - Outer	2
6	70016353	Upper Axle Tab - Backer	2
7	90001318	R-Joint 3/4-16 RH x 5/8 Bolt	4
8	90001319	R-Joint 3/4-16 LH x 5/8 Bolt	4
9	90003503	Lower Axle Mount	2
10	70013334	R-Joint Spacer - 5/8" ID x .620"	14
11	70013537	5/8 R Joint Spacer .625 ID x 2.843"	2
12	90003499	Lower 4-Link Bar	2
13	90002815	Upper 4-Link Bar	2
14	90001624	Aluminum Lower Shock Mount	2
15	70002825	Lower Shock Stud	2
16	90002067	Lower Shock Spacers - .625" I.D. x .450"	4
17	90002043	Upper Shock Spacers - .500" ID x .365"	4
18	90002285	Square U-Bolt	2
	85000008	3/8" Riv-Nut Installation Tool	1
	70010694	Bar Tab Setting Jig	2
	99371050	3/8-16 X 1 1/2 HX 1.12 CONI	6
	99372009	3/8"-16 U-Nuts - .090 -.20 Panel Thickness	6
	99010218	Hardware Kit: 70-81 F-Body 4-Link	1



### Major Components .....In the box

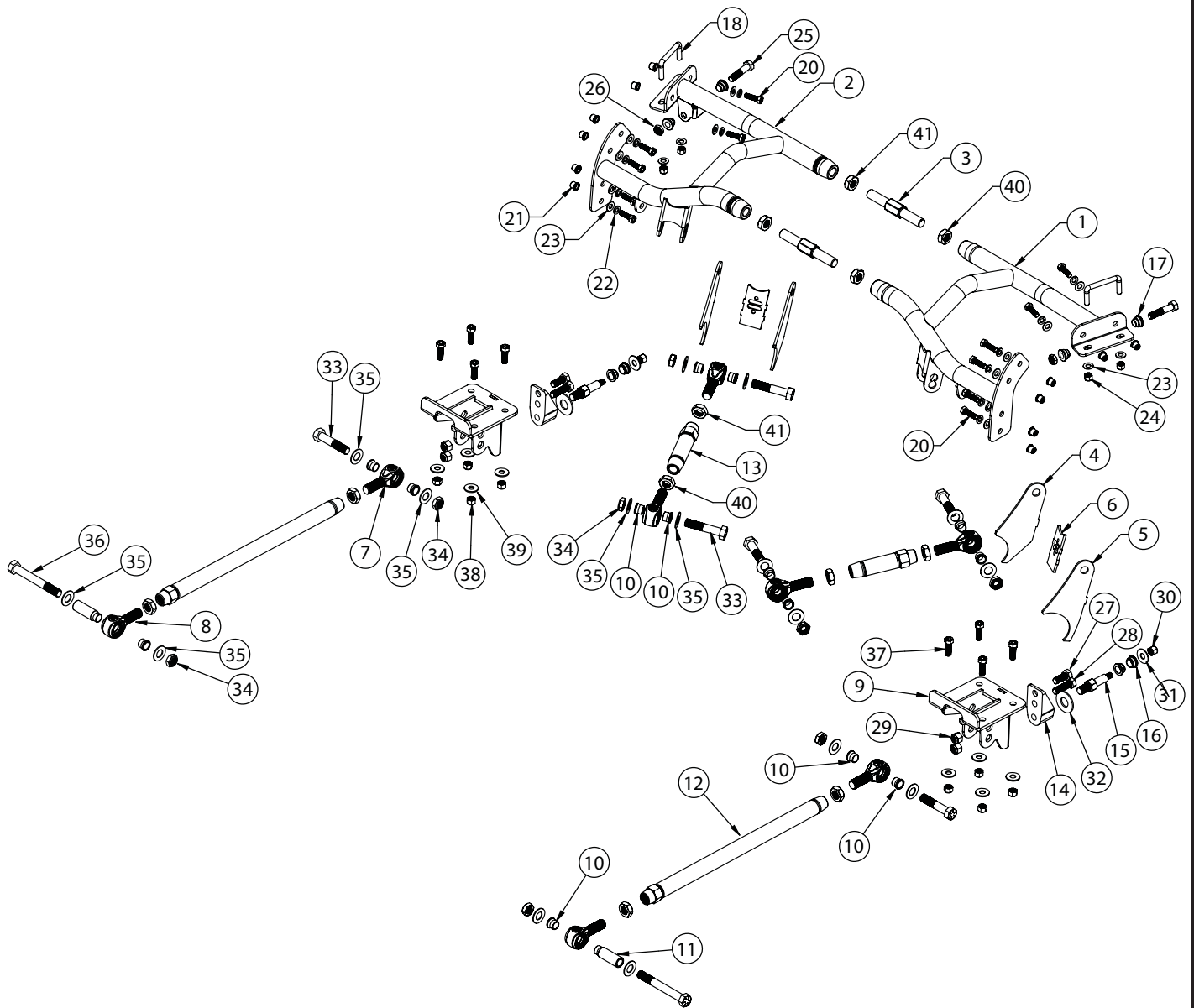

New R-Joints will be quite stiff (75-90 in/lbs breakaway torque) until they "break in" after a few miles of use. After the break in period they will move much more freely. Because the composite bearing race contains self lubricating ingredients, no additional lubrication is needed or desired. Any additional lubrication will only serve to attract more dirt and debris to the R-Joint and actually shorten its life.



### Hardware List .....In the box (Kit# 99010218)

The Hardware Kit contains bags to help aid in selecting the correct hardware for the component being installed. The hardware list shows how the hardware is bagged.

Item #	QTY	Part Number	Description	Item #	QTY	Part Number	Description
<b>CRADLE TO FRAME</b>				<b>UPPER 4 LINK BARS</b>			
19	1	85000007	17/32" Drill Bit	33	4	99621004	5/8"-18 x 3" Gr. 8 Bolt
20	12	99371005	3/8"-16 x 1 1/4" Hex Bolt	34	4	99622006	5/8"-18 Thin Nylok Nut
21	12	99372007	3/8"-16 Riv-Nut	35	8	99623001	5/8" SAE Flat Washer Gr. 8
22	12	99373006	3/8" Split Lock Washer		1	90002276	Anti-Seize
23	12	99373002	3/8" SAE Flat Washer GR 8	<b>LOWER 4 LINK BARS</b>			
	1	90002276	Anti-Seize	33	2	99621004	5/8"-18 x 3" Gr. 8 Bolt
<b>CRADLE U-BOLTS</b>				34	4	99622006	5/8"-18 Thin Nylok Nut
23	4	99373002	3/8" SAE Flat Washer GR 8	35	8	99623001	5/8" SAE Flat Washer Gr. 8
24	4	99372001	3/8"-16 Nylok Nut	36	2	99621007	5/8"-18 x 5" Gr. 8 Bolt
<b>UPPER SHOCK MOUNTING</b>					1	90002276	Anti-Seize
25	2	99501010	1/2"-20 x 2 1/4" Gr. 8 Bolt	<b>LOWER BAR MOUNT TO AXLE</b>			
26	2	99502003	1/2"-20 Thin Nylok Nut	37	8	99431006	7/16"-20 x 1 1/4" Hex Bolt
<b>LOWER SHOCK MOUNT</b>				38	8	99432007	7/16"- 20 Nylok Nut
27	2	99501007	1/2"-20 x 1 1/4" Hex Bolt	39	8	99433002	7/16" SAE Flat washer
28	2	99501009	1/2"-20 x 1 3/4" Hex Bolt	<b>RIGHT HAND &amp; LEFT HAND JAM NUTS</b>			
29	4	99502002	1/2"-20 Nylok Nut	40	6	99752004	3/4"-16 Jam Nut RH
<b>SHOCK STUD</b>				41	6	99752006	3/4"-16 Jam Nut LH
30	2	99432002	7/16"-20 Nylok Nut	<b>BAR SETTING JIG</b>			
31	2	99433002	7/16" SAE Flat Washer		2	99371001	3/8"-16 x 3/4" Hex Bolt
32	2	99623004	5/8" SAE Flat Washer		2	99372004	3/8"-16 Hex Nut

### Getting Started.....

Congratulations on your purchase of the Ridetech Rear 4-link System. This system has been designed to give your Camaro excellent handling along with a lifetime of enjoyment. This kit replaces the Leaf Springs, this allows the 4-Link to locate the rearend and the CoilOvers/ShockWaves to support the car. This allows each to be optimized for the best performance.

**Note:** These system is designed for use with the Ridetech Shockwaves or CoilOvers and the Ridetech Rear Sway Bar. **The factory shocks and springs will not fit this setup.**

1. Raise the vehicle to a safe and comfortable working height. Use jack stands to support the vehicle with the suspension hanging freely.



### Disassembly

2. Support the axle and remove the leaf springs, shocks, and tail pipes. If your car is equipped with a rear sway bar, it will also need to be removed. Refer to the factory service manual for proper disassembly procedures. **The rear brake line will need to be detached from the body. You will need to bleed the rear brakes after the installation is complete. You may need to redo the brake lines that are on the differential.**

The following steps show the removal of brackets, these can vary depending on the year of the car. Some years do NOT have some of the brackets shown. If your car doesn't have the particular bracket shown in a step, skip to the next step.



3. Cut the corner braces off that are located above the axle where the frame rail drops down. **Depending on the year of your car, it may not be equipped with these braces.** These can be removed by drilling the spot welds or cutting them off flush with the tabs, but we recommend drilling the spot welds.



4. Drilling the spot welds of the tabs will ensure a tighter fit of the cradle.



### Disassembly & Cradle Assembly



5. If your car has this style of exhaust bracket behind the axle, they will need to be cut off. Again, this can be done by drilling the spot welds or cutting off flush with the tabs. The early cars have a different style of mount that doesn't need to be cut off.



6. Unbolt the pinion snubber and remove it.



7. The upper cradle is adjustable to compensate for different frame rail widths found on the 70-81 Camaro. The cradle will need to be assembled before installing it in the car.



### Cradle Assembly

8.



8. The center adjuster has Right Hand Threads on one side, Left Hand Threads on the other side. This allows the cradle to be adjusted in the car. Install the jam nuts on the adjusters.

9.



9. Apply anti-seize to the end of the threads of the adjusters. We run about a 3/8" strip on them.

10.



10. The driver side of the cradle is Left Hand Threads, the passenger side is Right Hand Threads. Start the adjusters into opposite sides of the cradle, inserting them in approximately 2 revolutions.





### Cradle Assembly



**11.** The gap between the cradle halves is 1/4" shorter on the front tube than the rear tube. This allows the adjusters to be started at different times. Start the front adjuster into the opposite half of the cradle. Thread it in until the second adjuster is starting to hit the end of the threads of the thread bung.



**12.** Start the 2nd adjuster into the cradle. You may have to loosen or tighten the 1st adjuster to get the 2nd started.



**13.** With both adjusters started. Thread them in evenly until the cradle is narrow enough to fit in your car. The gaps between the front and rear adjusters should be approximately 1/4" difference with the gap of the front tube being the lesser of the two. If an adjuster starts getting tight to turn, switch to the opposite adjuster until it starts getting tight. Go back and forth between the 2 to achieve a width that will fit your car.



### R-Joint Bar Assembled

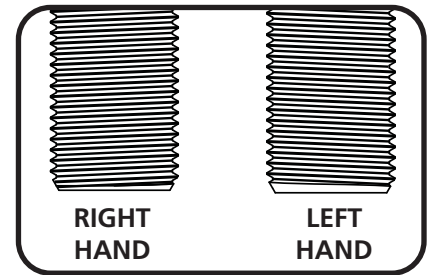
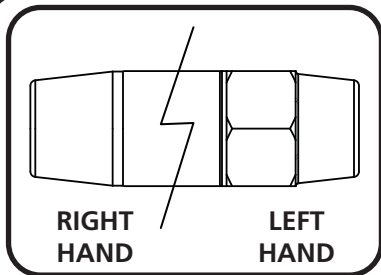

THE 4-LINK BARS, R-JOINTS, AND JAM NUTS HAVE RIGHT HAND AND LEFT HAND THREADS. THIS ALLOWS THE BAR TO BE ADJUSTED WITHOUT REMOVING IT. THE HEX END OF THE BAR IS LEFT HAND THREAD. THE LEFT HAND JAM NUT HAS AN COUNTER-CLOCKWISE ARROW STAMPED INTO IT. IMAGE 3 WILL HELP YOU DETERMINE THE THREADS OF THE R-JOINTS.

#### 14a. Component List:

1. 4-Link Bar
2. Right Hand Thread R-joint
3. Right Hand Thread Jam Nut
4. Left Hand Thread R-Joint
5. Left Hand Thread Jam Nut

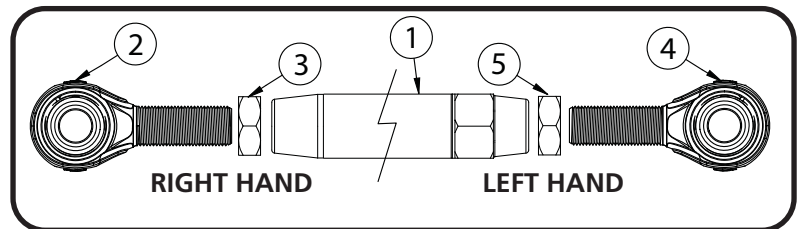

**14b.** Thread the jam nuts onto the threaded shank of the r-joints. Thread the nuts all the way on to the r-joint.

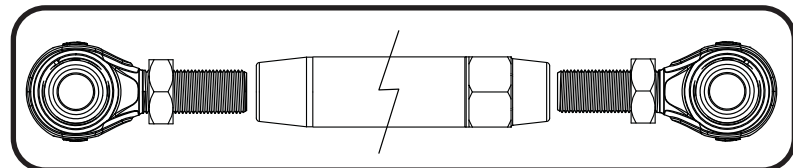

**14c.** *Apply anti-seize to the threads of the r-joint.* This will prevent the threads from gulling.



**14d.** Thread the r-joints into the 4-link bar. Thread them in evenly until you achieve the correct center to center length.

**Upper Bar Length: 9 1/4"**  
**Lower Bar Length: 24 1/4"**

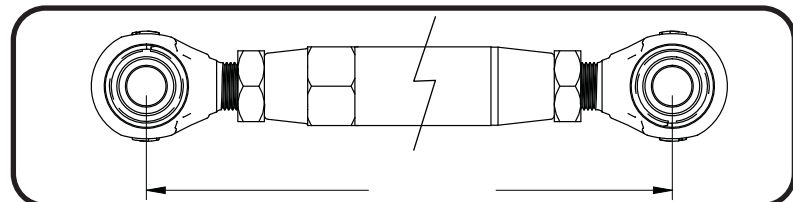

**14e.** After getting one bar length set, you can put a 5/8" bolt through the r-joints to simplify setting the next bar. Adjust the bar length of the 2nd bar until it will slip on and off the bolts. Torque the jam nuts 65-75 ft-lbs using an 1 1/8" crows foot on a torque wrench.





### Cradle Installation



**15.** Insert the cradle into the car. The rear of the cradle is tapered to fit the frame. You will need to adjust the center adjuster to get a tight fit on the frame. You will need to support the cradle with something or have a helper hold it in place.



**16.** Adjust the center adjusters evenly until the cradle gets tight against the frame. You will need to adjust the front and rear evenly until it fits tight. The horizontal tab on the rear section of the cradle will fit against the bottom of the frame and the vertical surface should be snug against the frame rails.



**17.** You will need to alternate between the adjusters to get them adjusted out evenly.



### Cradle Installation



**18.** Image 18 shows the cradle in place. When it is snug against the frame, it will hold in place by itself.



**19a.** Use the frame plates as a template to drill the holes in the bottom of the frame rails. Use a 7/16" drill bit to drill the holes. Drill the slotted hole in the center of the slots.



**19b.** It might be necessary to elongate the holes a little to get the u-bolt inserted.



### Cradle Installation



**20.** Feed one end of the u-bolt through the round hole of the pair of holes, using the other end of the u-bolt as a handle. You need to get the end of the u-bolt that you are using as a handle fed in until it is past the 90 degree bend to be able to drop the other end through the drilled hole. If the u-bolt will not line up with the drilled holes, it may be necessary to slot the frame hole in the slotted hole of the frame mount.



**21.** The other leg of the u-bolt needs to drop through the opposite hole of the hole you are inserting the u-bolt in.



**22.** Install (1) 3/8" flat washer and (1) 3/8"-16 nylok nut onto each stud sticking through the cradle. Do not tighten them until all washers and nuts are installed. Tighten each leg of the u-bolt evenly. Torque to 30 ftlbs. Do this for all (4) u-bolts..



### Riv-nut® Installation & Specs

**1.** Drill Hole in Frame using the SUPPLIED DRILL BIT keeping the Drill square with the metal.

**2.** We recommend installing (2) 3/8" Flat Washers between the bolt head and the lower anvil of the installation tool. Thread a Riv-nut® onto the supplied Tool. Thread the Riv-nut all the way onto the Tool until it stops.

**3.** Insert the Tool and Riv-nut® into the drilled hole 90° to the Frame Rail.

**4.** The Tool requires (1) 9/16" & (1) 5/8" Wrenches to use. A Ratchet can be used on the top of the Tool.

**KEEP THE TOOL AND RIV-NUT 90° TO THE SURFACE WHILE TIGHTENING**

**5.** Put a 5/8" Wrench on the Lower Hex of the tool. Use a 9/16" Wrench or Ratchet on the Top hex to Tighten.

**6.** Hold the Wrench in one position and turn the TOP HEX CLOCKWISE to engage the Riv-nut®. Keep Turning the TOP WRENCH until you feel a positive stop and you can't turn the TOP WRENCH anymore.

**7.** Break the Tool loose by turning the TOP HEX counterclockwise and thread the Tool out of the Riv-nut®

**THE DATA BELOW ILLUSTRATES THE STRENGTH OF THE RIV-NUT®**

#### RIVNUT® Fastener Engineering Data

Upset Load (lbs.)		
RIVNUT * Size	Steel	
	Min. Grip	Max. Grip
3/8-16	4965	5325

Fig. 1

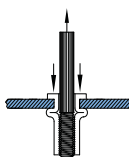

Ultimate thread strength (lbs.)		
RIVNUT * Size	Steel	
	Min. Grip	Max. Grip
3/8-16	11500	10450

Fig.2

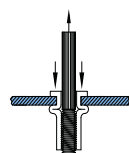

Ultimate tensile strength (lbs.)	
RIVNUT * Size	Steel
3/8-16	3900

Fig. 3

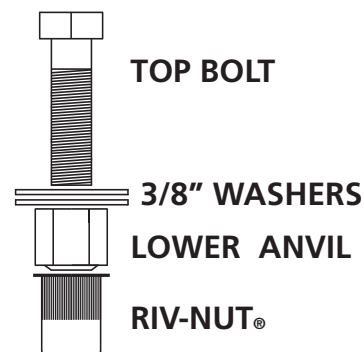
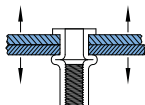

Figure 2

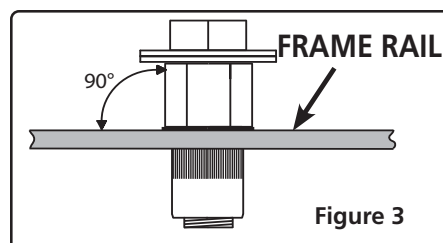

Figure 3

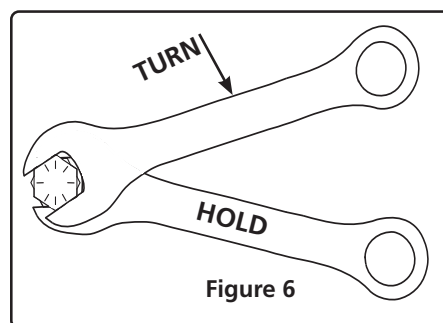

Figure 6

**Single Shear Strength 3/8" Grade 5 Bolt  
3,975.8 lbs**



### Cradle Installation



**23.** Mark the holes in the frame for the vertical mounting plates. There are 4 holes in the front plate, 2 holes in the rear plate. Do this for both sides. The cradle will now need to be removed to install the Riv-nuts.



**24.** The holes for the Riv-nuts NEED to be drilled with the supplied 17/32" drill bit. We suggest drilling the holes with a smaller drill bit first to make it easier to drill with the 17/32" drill bit. Drill all (12) holes in the sides of the frame rails.



**25.** Install the Riv-nuts in the sides of the frame rails. **Refer to the Riv-nut installation instructions on PAGE 13 for proper Riv-nut installation.** Image 25 illustrates a Riv-nut being installed. Install all (12) Riv-nuts in the frame rails.



### Cradle Installation



**26.** Reinstall the cradle in the car. Reinstall the 3/8" hardware on the u-bolts. Do not tighten them until all washers and nuts are installed. Tighten each leg of the u-bolt evenly. Torque to 30 ftlbs. Do this for all (4) u-bolts.



**27.** Install a 3/8" split lock washer, and a 3/8" flat washer on each of (16) 3/8"-16 x 1 1/4" hex bolts. Thread a bolt/washer in to each of the Riv-nuts installed in the frame rails. Install all 12 bolts/washers before tightening any of the bolts. Torque the bolts to 23 ftlbs.



**28.** Tighten the adjuster jam nuts against the tubes of the cradle.





### Installing Lower Bars



**29.** Drill the front leaf spring mounting holes to 5/8".



**30.** Check the length of the lower bar; it should be 24 1/4" center to center. The R-joint setup is designed to be offset to the inside of the car. The R-joint uses a .620" spacer (70013334) on the inside with a 2.593" long spacer (70013537) on the outside. Insert the small OD of the spacer into the r-joint center ball. Push the spacers in until they bottom out in the center ball.



**31.** Align the r-joint/spacers with the 5/8" hole. Install a 5/8" flat washer on a 5/8"-18 x 5" hex bolt. Install the bolt/washer in the aligned holes. **The bolt needs to be installed in the same orientation as Image 31.**



### Installing Lower Bars & Axle Mount



**32.** Install a 5/8" flat washer and 5/8"-18 thin nylok nut on the threads of the bolt. Tighten the bolt/nut enough to eliminate any gaps.



**33.** Attach the lower bar/mount assembly to the car. New 3/8"-16 u-nuts and 3/8-16" x 1 1/2" conical body Bolts are supplied in the kit. Install the u-nuts in place of the OEM u-nuts. Hold the assembly in place lining up the holes with the u-nuts. There is a tab bent up on the mount that indexes into a hole in the body. Make sure the tab is indexed into the alignment hole. Torque the mounting bolts to 30 ft-lbs.



**34.** The lower axle bracket will be fastened to the leaf spring pad using the factory T-bolts/U-bolts or the supplied 7/16"-20 x 1 1/4" hex bolts. Align the mounting holes of the axle mount with the hardware sticking through the OEM leaf spring mount. Install a 7/16" flat washer & 7/16"-20 nylok nut on the threads sticking through the axle mount. Torque the nuts to 55 ft-lbs. Install both axle mounts.



### Installing Lower Shock Mount & Lower Bars



**35.** The lower shock mount attaches with (1) 1/2"-20 x 1 1/4" hex bolt, (1) 1/2"-20 x 1 3/4" hex bolt, & (2) 1/2"-20 nylok nuts. The lower mount gets attached to the 2nd and 3rd hole up from the bottom of the axle mount. When the shock mount is installed correctly, the bottom of the lower shock mount is 1/8" below the bottom of the axle mount.



**36.** Insert the bolts through the aluminum shock mount with the 1 1/4" long bolt in the top bolt, 1 3/4" in the bottom hole. Insert the bolts through the axle mount and install the nylok nuts on the threads sticking through. Repeat on both sides and torque the bolts/nuts to 75 ft-lbs.



**37.** The R-joint uses a .620" spacer (70013334) on each side. Insert the small OD of the spacer into the r-joint center ball. Push the spacers in until they bottom out in the center ball.



### Installing Lower Bars



**38.** Align the R-joint with the **TOP** hole of the axle mount. Install a 5/8" flat washer on a 5/8"-18 x 3" hex bolt.



**39.** Insert the bolt/washer through the axle mount/bar.



**40.** Install a 5/8" flat washer and 5/8"-16 thin nylok nut on the threads of the bolt. Do this for both sides. Tighten the bolt/nut enough to eliminate any gaps.



### Setting Pinion Angle

**READ PAGES 20-23 ON SETTING PINION ANGLES, UPPER BAR TAB JIG INSTALLATION, & SETTING RIDE HEIGHT.**

How do you set the pinion angle? On a single-piece shaft you want to set it up where a line drawn through the center of the engine crankshaft or output shaft of the transmission and a line drawn through the center of the pinion are parallel to each other but not the same line.

Your transmission angle should be around 3 degrees down in the rear. If it is more or less than 3 degrees, you might want to consider changing it. Too little angle on the transmission reduces the amount of oil getting to the rear bushing. Too much transmission angle will increase the working angles of the u-joints which will increase the wear. With the transmission at 3 degrees down in the rear, you will want to set the pinion 3 degrees up in the front.

A simple way to do this is to place a digital angle finder or dial level on the front face of the lower engine pulley or harmonic balancer. This will give you a reading that is 90 degrees to the crank or output shaft unless you have real problems with your balancer. At the other end, you can place the same level or angle finder against the front face of the pinion yoke that is also at 90 degrees to the centerline. If you rotate the yoke up or down so both angles match, you have perfect alignment.

Road testing will tell you if you have it right. If you accelerate and you get or increase a vibration, then the pinion yoke is too HIGH. Rotate it downward in small increments of a degree or two until the problem goes away. If you get or increase a vibration when decelerating, then the pinion yoke is too LOW. Rotate it upward to correct it.

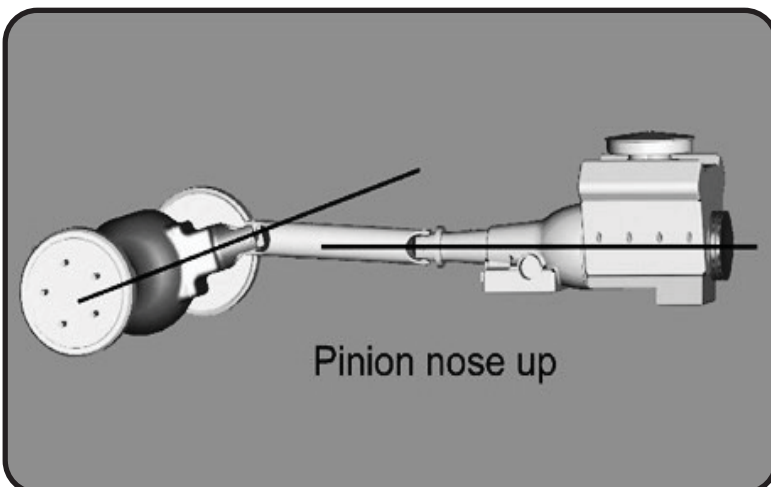
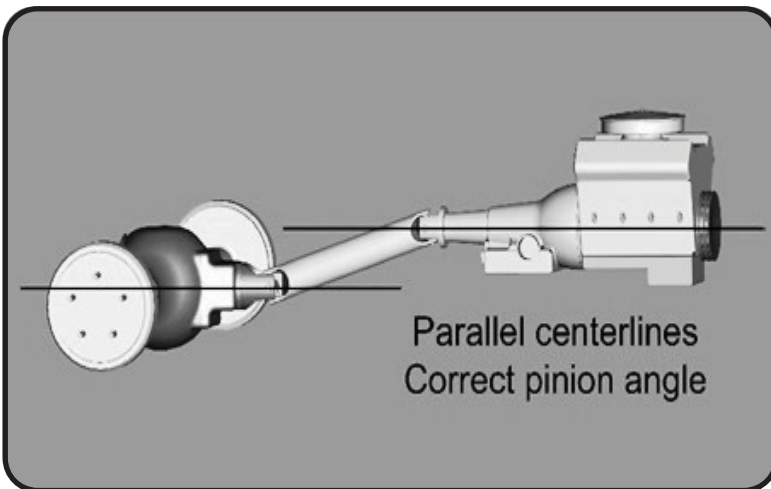
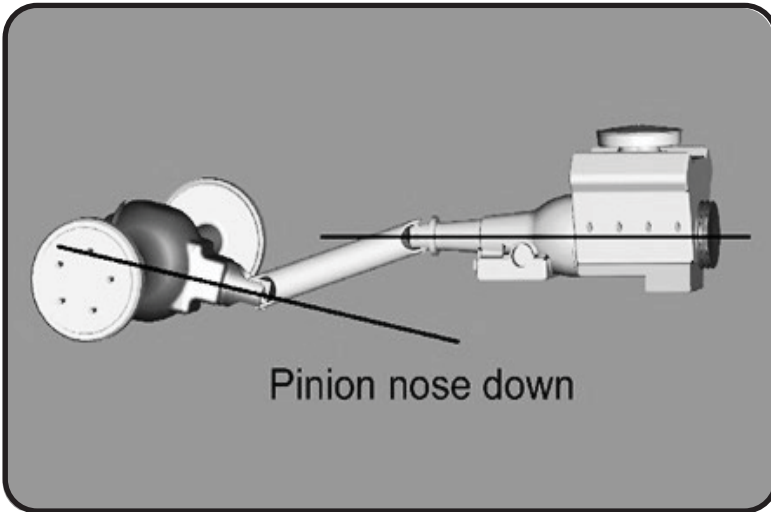



### Upper Bar Tab Installation Jig

#### Upper Bar Installation Jig

- This jig has been supplied to aid in the installation of the upper 4 link bar. It can be temporarily used to properly align, locate and weld the tabs onto the axle. It will also ensure that the mounting bolts are parallel to the ground.
- Follow the diagram below to set the jig to the same length as the upper bar, use the 3/8" x 3/4" bolt and nuts to set the length.
- Position the axle at ride height. Center the axle left to right between the quarter panels. Set pinion angle.
- Bolt one end of the jig to the cradle using a 5/8" x 3" bolt.
- Using another 5/8" x 3" bolt, fasten the axle tabs to the other end. The inner tabs will get bolted to the jig tab with the dog legged edge to the rear. The outer tab will have the long straight edge rearward. The tabs must be bolted to the outside of the jig. Both tabs should have the tab backer locating tabs to the rear of the car.
- Swing the bar down letting the tabs rest onto the axle. Trim the brackets as necessary to minimize the gap to be welded.
- Check pinion angle, ride height and axle center. Tack-weld the tab assemblies in place on the axle.
- Remove jig and install upper bar.
- Repeat this process for the other side.
- Recheck pinion angle, ride height and axle center. (Sound familiar?)
- After the tabs have been tack welded on both sides, remove the setting jig. Let the axle drop down for better access to the tabs. Lay 1" welds on the inside and outside of the tabs. Skip around from one side to the other to avoid overheating the tube.

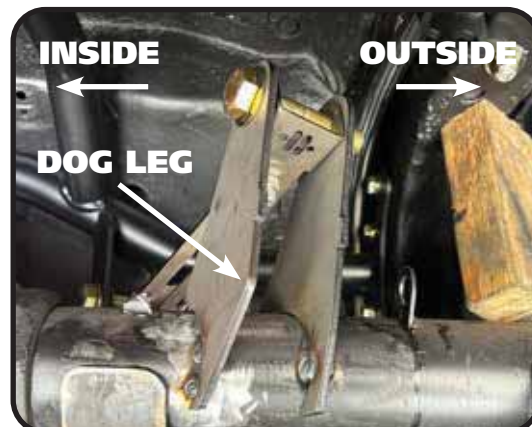
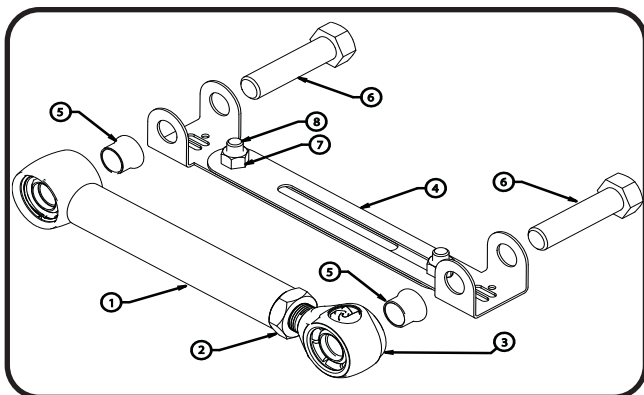

Item#	Description
1	Upper Bar
2	3/4"-16 Jam Nut
3	R-Joint End
4	Alignment Jig
5	Aluminum Spacer
6	5/8" x 2 3/4" Bolt
7	3/8"-16 Nut
8	3/8"-16 x 3/4" Bolt



### Installing Upper Bars Tabs



**41.** One helpful trick to help maintain ride height and pinion angle while adjusting is to tack weld a spacer between the axle and the outside of the frame as shown in the picture. This spacer should be 5 1/2" tall giving the CoilOver/Shockwave an eye-to-eye measurement of approximately 14 1/2". When measuring the axle center you can measure off of the frame rails. We also use a plum bob off the quarter panels to double check the axle center. Refer to **Page 20** on setting the pinion angle.



**42.** Check the length of the upper bar; it should be 9 1/4" center to center. Bolt the axle tabs to the setting jig as specified on the previous page. Next, place the other end into the cradle. Both ends use a 5/8" x 3" and should not be fully tightened yet. For now just let axle tabs sit on the axle.



**43.** Check the fitment of the tabs to the axle.



### Installing Upper Bars Tabs & Bars



**44.** Put the tab back brace in position. The curve of the brace should be up. The 2 tabs on each side of the brace need to be positioned on each side of the tab on the REAR of the axle tabs. Tack weld everything in place and repeat for the other set of axle tabs. After the tabs have been tack welded on both sides, remove the setting jig. Let the axle drop down for better access to the tabs. Lay 1" welds on the inside and outside of the tabs. Skip around from one side to the other to avoid overheating the tube.



**45.** The R-joint uses a .620" spacer (70013334) on each side. Insert the small OD of the spacer into the r-joint center ball. Push the spacers in until they bottom out in the center ball. Do this for both ends of the upper bar.



**46.** The upper bar mount that is made into the cradle has 2 mounting positions. **THE STANDARD MOUNTING POSITION IS THE BOTTOM HOLE.** Insert the front of the upper bar in the BOTTOM hole of the upper bar mounting. Install a 5/8" flat washer on a 5/8"-18 x 3" hex bolt. Insert the bolt/washer in the aligned holes. Install a 5/8" flat washer and 5/8"-18 nylok nut on the bolt. Repeat on both sides and tighten the bolts/nuts enough to eliminate any gaps.





### Installing Upper Bars



**47.** Verify the spacers are installed in the R-Joints of the upper bars.



**48.** Insert the R-Joint into the upper bar mount of the rear differential. Install a 5/8" Flat Washer on to a 5/8"-16 x 3" hex bolt. Line up the holes in the axle tabs with the through hole of the R-Joint, insert the bolt/washer.



**49.** Install a 5/8" flat washer followed by a 5/8"-18 thin jam nylok nut. Repeat on both sides and tighten the bolts/nuts enough to eliminate any gaps.



### Installing Lower Shock Stud & CoilOvers/ShockWaves



**50.** Installing the shock stud into the lower mount. Install a 5/8" flat washer onto the 5/8"-18 threads of the shock stud. Apply Red Loctite to the 5/8" threads of the stud. Thread the shock stud into the threaded hole of the lower mount. Repeat on both sides and torque the shock stud to 65-75 ftlbs.



**51.** Ridetech CoilOvers or ShockWaves require a spacer on each side of the bearing. The upper crossmember uses a 1/2" ID spacer that is .605" long (90002043). The overall width with a spacer on each side will be 1 1/4". **The small OD of the spacer will insert into the shock bearing.**



**52.** Insert the 1/2" ID shock bearing spacer into each side of the ShockWave/CoilOver bearing. If installing ShockWaves, insert the top of the shock into the shock mount on the upper crossmember with the adjusting knob to the inside. If installing CoilOver, insert the bottom of the shock into the shock mount on the upper crossmember. Line up the holes in the upper shock mount with the spacers and shock bearing. Install a 1/2"-20 x 2 1/4" Hex Bolt into the lined up holes. Install a 1/2"-20 thin jam nylok nut. Torque to 22 ft-lbs.



### Installing CoilOvers/ShockWaves



53. The shock stud requires spacers that are 5/8" ID x .400" long (90002067). Install a 90002067 spacer (**Small side towards shock body**) onto the lower Shock Stud.



54. Slide the bottom of the shock onto the stud. Install a second 5/8" ID 90002067 spacer onto the Stud (**small side towards shock**). You may need to jack the rearend up to slide the shock onto the stud. Install the 7/16" flat washer and 7/16" nylok nut. Tighten the upper and lower shock bolts. Torque the lower nut to 40 ftlbs. The designed ride height of the CoilOver/Shockwave is 14 1/2" center to center.



### Anti Squat Adjustment

The Upper Bar Mounts and Lower Axle Mounts are designed with adjustable Anti Squat. Anti Squat reduces the amount the rear suspension squats on acceleration. Anti Squat is measured in a percentage, the higher the percentage of anti squat the less the rear of the car squats. Reducing the rear squat keeps the rear suspension from compressing as much therefor reducing the amount the front suspension extends. This will help keep the suspension geometry in it's optimized range. Anti squat uses the mechanics of the rear suspension to reduce squat rather than the shocks and springs. It uses the same mechanics to help put weight to the rear tires during acceleration. Several factors effect the amount of anti squat a car needs; horsepower, tires, vehicle weight, and track surface are some of the main ones. You can use the different settings in this suspension to help dial in your car's handling. Keep in mind, the higher the rear squat percentage the less effective the rear tires will be under hard braking for corner entry.

We control the Anti squat percentage by raising and lowering the front of the upper bar and rear of the lower bar. The standard position is approximately 55% Anti Squat at the designed ride height. We have found this to be a good starting point and a great setting for driving. Keep in mind, your ride height will affect the anti squat percentage and instant center. ALL OF THESE NUMBERS ARE BASED AROUND 14 1/2" RIDE HEIGHT OF SHOCKWAVE OR COILOVER.

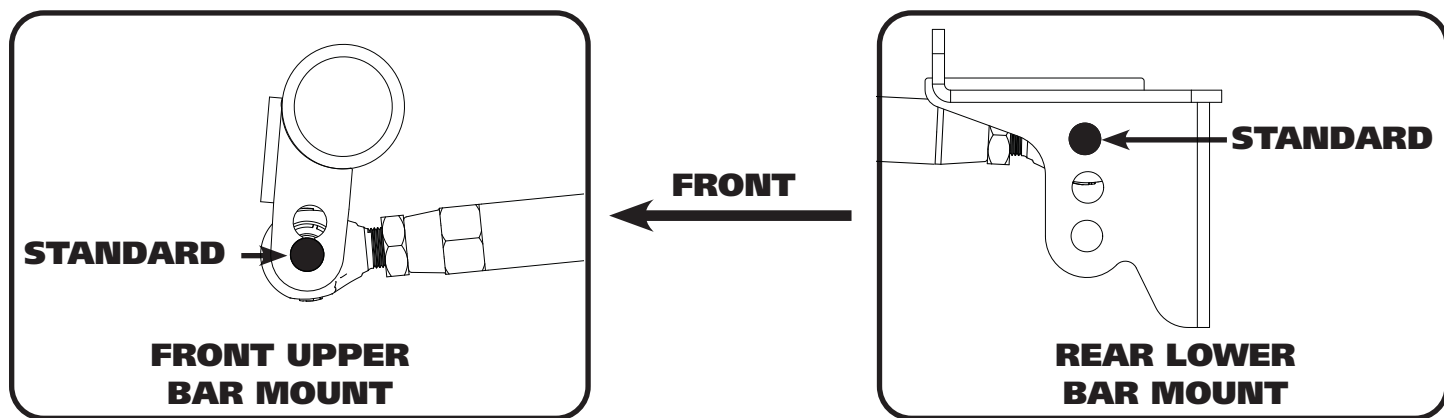

### ADJUSTMENT GUIDE

**THE STANDARD SETTING IS WITH THE TOP BAR IN THE LOWER HOLE AND THE LOWER BAR IN THE TOP HOLE.**

UPPER BAR POSITION	LOWER BAR POSITION	ANTI SQUAT % OF CHANGE FROM STANDARD SETTING	INSTANT CENTER CHANGE
TOP HOLE	TOP HOLE	<b>WE RECOMMEND NOT USING THIS SETTING</b>	
TOP HOLE	MIDDLE HOLE	0 %	+ 80"
TOP HOLE	BOTTOM	+ 30 %	+ 20"
BOTTOM HOLE	MIDDLE HOLE	+ 25 %	- 21"
BOTTOM HOLE	BOTTOM HOLE	+ 50 % *	- 32" *

\* This setting is recommended for straight line applications only. The steeper lower bar angle is not recommended for handling applications.



### Part # 11176510 - 1970-1981 GM "F" Body HQ Rear CoilOvers

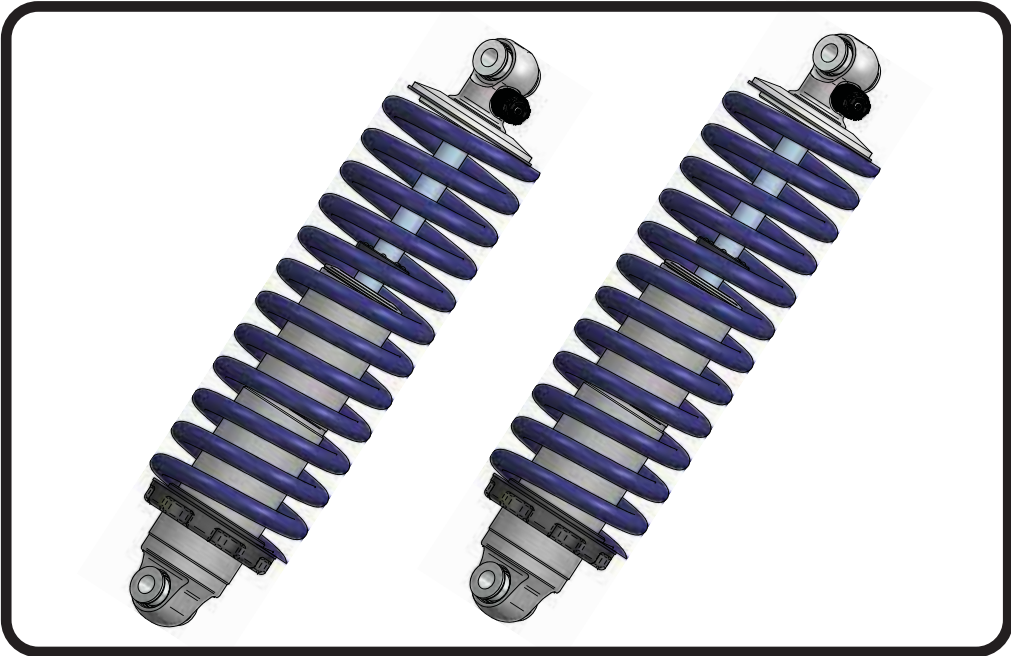

#### Recommended Tools

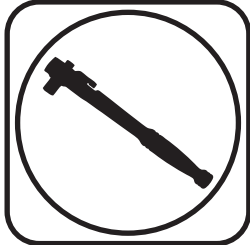

### 1970-1981 GM "F"Body HQ Series Rear CoilOvers

# Installation Instructions

Table of contents

Page 46..... Included Components

Page 47..... Assembly and Adjusting

Page 48..... Final Adjusting and Preloading the Spring

ShockWave Dimensions:

Center of bearing to Center of bearing:	
Compressed:	11.23"
Ride Height:	14.50"
Extended:	16.43"



### Major Components .....In the box

Item #	Part #	Description	QTY
1	982-10-805	5.2" Stroke HQ Series Shock	2
2	815-05-022-KIT	1.7" Shock Eyelet	2
3	803-00-109(kit)	Upper CoilSpring Retaining Plate (803-00-109 kit)	
4	59120200	Coilspring 12" 200lb	2
5	70010828	Delrin Spring Washer	4
6	803-00-109(kit)	Lower Spring Adjuster Nut (803-00-109 kit)	2
7	803-00-109(kit)	Adjuster Nut Locking Screw (803-00-109 kit)	2
8	803-00-109(kit)	Retaining Ring (803-00-109 kit)	2
	90001994	5/8" ID Bearing (installed in shock and eyelet)	4
	90001995	Bearing Snap Ring (installed in shock and eyelet)	8

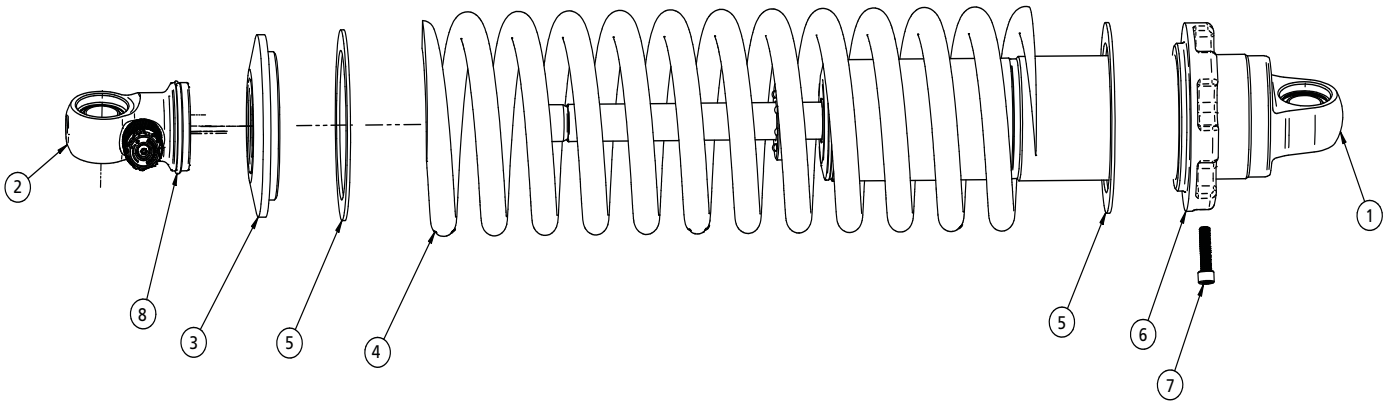

## CoilOver Assembly...



1

First, using the supplied lower adjuster nut (803-00-199) thread the nut onto the shock from the bottom side as seen in figure 1. Remove the plastic pellet that is in the split of the adjuster nut.



4

Once the knob is removed slide a Delrin washer over the eyelet. Next, slide the upper spring mount (803-00-199) over eyelet as seen in figure 4.



2

Next, install a delrin washer then coil spring over the top of the shock as seen in figure 2.



5

Install upper spring mount retainer clip (803-00-199) into the groove on the upper eyelet as seen in figure 5. Then, reinstall adjuster to complete assembly.



3

Before the upper spring mount can be installed screw the adjuster knob on the upper eye mount to the firmest setting (clockwise) as seen in figure 3. Then remove the Knob by holding it while removing the center screw.

**Install the locking screw in the adjuster nut before setting spring preload, but DO NOT tighten until the spring preload has been set.**

**NOTE:** Remember to adjust the shock valving before driving, the shock is currently set to full stiff.

## Shock Adjustment 101- Single Adjustable

### Rebound Adjustment:

How to adjust your new shocks.

The rebound adjustment knob is located on the top of the shock absorber protruding from the eyelet. You must first begin at the ZERO setting, then set the shock to a medium setting of 12.



-Begin with the shocks adjusted to the ZERO rebound position (full stiff). Do this by rotating the rebound adjuster knob clockwise until it stops.

-Now turn the rebound adjuster knob counter clock wise 12 clicks. This sets the shock at 12. (settings 21-24 are typically too soft for street use).

Take the vehicle for a test drive.



-if you are satisfied with the ride quality, do not do anything, you are set!

-if the ride quality is too soft increase the damping effect by rotating the rebound knob clock wise 3 clicks.

Take the vehicle for another test drive.



-if the vehicle is too soft increase the damping effect by rotating the rebound knob clock wise 3 additional clicks.

-If the vehicle is too stiff rotate the rebound adjustment knob counter clock wise 2 clicks and you are set!

Take the vehicle for another test drive and repeat the above steps until the ride quality is satisfactory.

### Note:

**One end of the vehicle will likely reach the desired setting before the other end. If this happens stop adjusting the satisfied end and keep adjusting the unsatisfied end until the overall ride quality is satisfactory.**



## Final Tightening and Adjusting

### Ride Height

We have designed most cars to have a ride height of about 2" lower than factory. To achieve the best ride quality & handling, the shock absorber needs to be at 40-60% overall travel when the car is at ride height. This will ensure that the shock will not bottom out or top out over even the largest bumps. Measuring the shock can be difficult, especially on some front suspensions. Measuring overall wheel travel is just as effective and can be much easier. Most cars will have 4-6" of overall wheel travel. One easy way to determine where you are at in wheel travel is to take a measurement from the fender lip (center of the wheel) to the ground. Then lift the car by the frame until the wheel is just touching the ground, re-measure. This will indicate how far you are from full extension of the shock. A minimum of 1.5" of extension travel (at the wheel) is needed to ensure that the shock does not top out. If you are more than 3" from full extension of the shock then you are in danger of bottoming out the shock absorber.

### Adjusting Spring Height

When assembling the CoilOver, screw the spring retainer tight up to the spring (0 preload). After entire weight of car is on the wheels, jounce the suspension and roll the car forward and backward to alleviate suspension bind.

- If the car is too high w/ 0 preload then a smaller rate spring is required. Although threading the spring retainer down would lower the car, this could allow the spring to fall out of its seat when lifting the car by the frame.
- If the car is too low w/ 0 preload, then preload can then be added by threading the spring retainer up to achieve ride height. On 2.6" - 4" stroke shocks, up to 1.5" of preload is acceptable. On 5-7" stroke shocks, up to 2.5" of preload is acceptable. If more preload is needed to achieve ride height a stiffer spring rate is required. Too much preload may lead to coil bind, causing ride quality to suffer.