



1966-67 Chevrolet Chevelle

without Factory Air
Gen 5 Evaporator Kit
(561273)



18865 Goll St. San Antonio, TX 78266
Phone: 800-862-6658
Sales: sales@vintageair.com
Tech Support: tech@vintageair.com
www.vintageair.com



www.vintageair.com

Table of Contents

Cover.....	1
Table of Contents.....	2
Packing List/Parts Disclaimer.....	3
Information Page.....	4
Wiring Notice.....	5
Engine Compartment Disassembly, Condenser Assembly and Installation, Compressor and Brackets.....	6
Passenger Compartment Disassembly.....	7
Firewall Modification, Firewall Cover Preparation.....	8
Firewall Cover Installation and Insulation, Defrost Duct Prepration & Installation.....	9-10
66 Chevelle Kick Panel Modification.....	11
67 Chevelle Kick Panel Modification.....	12
Driver and Passenger-Side Louver Installation.....	13
Driver Side Louver Template.....	14
Passenger Side Louver Template.....	15
Center Louver Installation, Alternate Mounting Procedure.....	16-18
Alternate Mounting Procedure (Cont.).....	19
Fresh Air Cap & Kick Panel Cover Preparation.....	20
Lubricating O-rings, Properly Seated O-ring Land.....	21
Evaporator Module Preparation, Wiring Installation.....	22-23
Wiring Installation (Cont.), Kick Panel Fresh Air Cap Installation.....	24
Evaporator Installation, Drain Hose Installation.....	25-27
Fresh Air Cap Installation, Heater Hose & Heater Control Valve Installation.....	28
Heater Hose & Heater Control Valve Installation (Cont.), A/C Hose Installation.....	29
A/C and Heater Hose Routing.....	30
Dash Support Bracket Installation, Wiring Final.....	31
Engine Compartment Wiring.....	32
Final Steps: Installation Check.....	33
Final Steps: Completing the Install.....	34
ECU, Control Panel & Duct Hose Routing.....	35
Quality Crimp Guideline.....	36
Gen 5 Wiring Diagram.....	37
Gen 5 Wiring Connection Instruction.....	38
Operation of Controls.....	39
Troubleshooting Guide.....	40
Troubleshooting Guide (Cont.), Advanced Diagnostics and Troubleshooting Guide.....	41
1966 Chevelle Kick Panel Modification Template.....	42
1967 Chevelle Kick Panel Modification Template.....	43
Packing List.....	44



www.vintageair.com

Packing List: Evaporator Kit (561273)

No.	Qty.	Part No.	Description
1.	1	765225	Gen 5 Super Magnum Module with 444 ECU
2.	1	781273	Accessory Kit

**** Before beginning installation, open all packages and check contents of shipment. Please report any shortages directly to Vintage Air within 15 days. After 15 days, Vintage Air will not be responsible for missing or damaged items.**

1



**Gen 5 Super Magnum
Module with 444 ECU
765225**

2

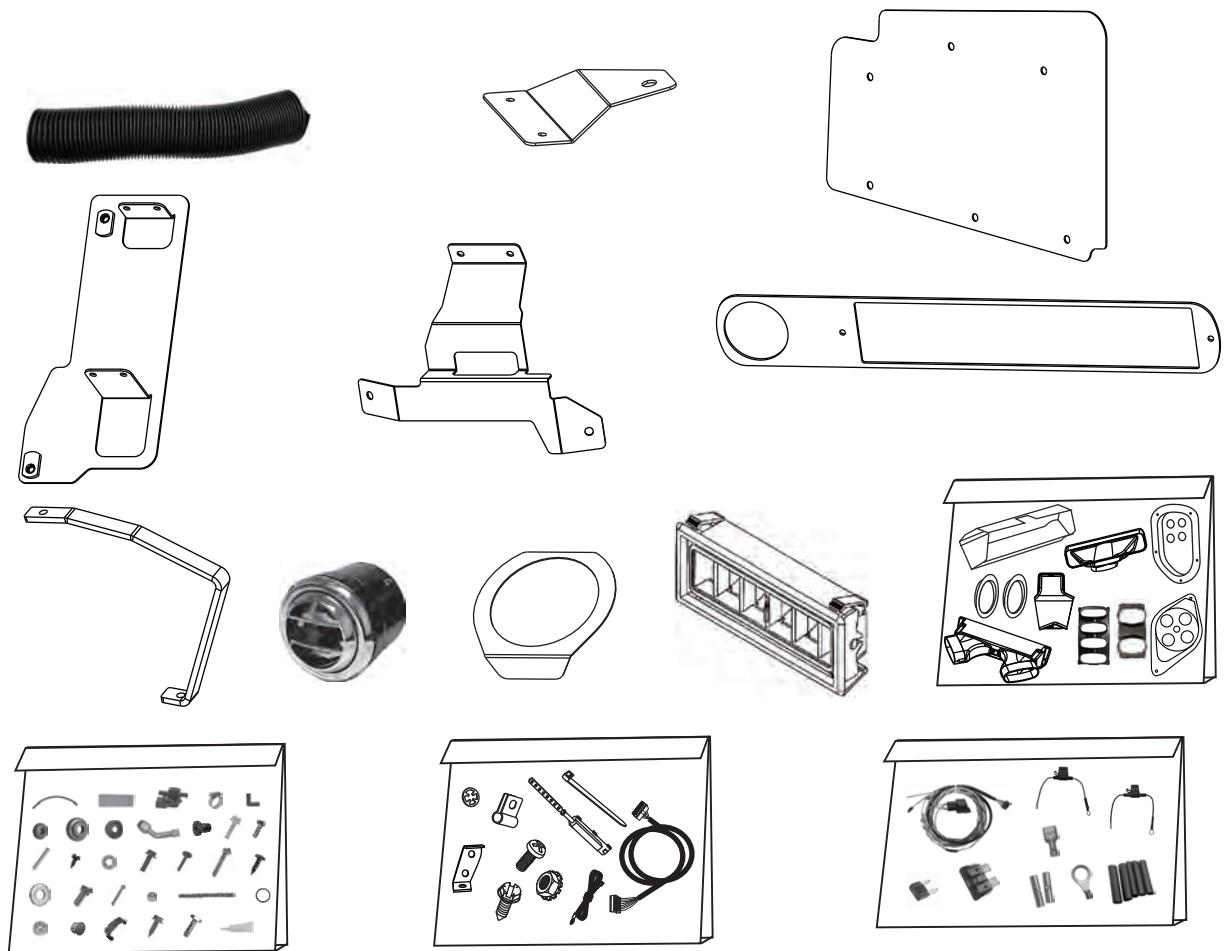

**Accessory Kit
781273**

NOTE: Images may not depict actual parts and quantities. Refer to packing list for actual parts and quantities.



www.vintageair.com

Important Notice—Please Read

For Maximum System Performance, Vintage Air Recommends the Following:

NOTE: Vintage Air systems are designed to operate with R134a refrigerant only. Use of any other refrigerant could damage your A/C system and/or vehicle, and possibly cause a fire, in addition to potentially voiding the warranties of the A/C system and its components.

Refrigerant Capacities:

Vintage Air System: 1.8 lbs. (28.8 oz.) or 816 grams of **R134a**, charged by weight with a quality charging station or scale. **NOTE: Use of the proper type and amount of refrigerant is critical to system operation and performance.**

Other Systems: Consult manufacturer's guidelines.

Lubricant Capacities:

New Vintage Air-Supplied Sanden Compressor: No additional oil needed (Compressor is shipped with proper oil charge).

All Other Compressors: Consult manufacturer (Some compressors are shipped dry and will need oil added).

Safety Switches

Your Vintage Air system is equipped with a binary pressure safety switch. A binary switch disengages the compressor clutch in cases of extreme low pressure conditions (refrigerant loss) or excessively high head pressure (406 PSI) to prevent compressor damage or hose rupture. A trinary switch combines Hi/Lo pressure protection with an electric fan operation signal at 254 PSI, and should be substituted for use with electric fans. Compressor safety switches are extremely important since an A/C system relies on refrigerant to circulate lubricant.

Service Info:

Protect Your Investment: Prior to assembly, it is critical that the compressor, evaporator, A/C hoses and fittings, hardlines, condenser and receiver/drier remain capped. Removing caps prior to assembly will allow moisture, insects and debris into the components, possibly leading to reduced performance and/or premature failure of your A/C system. This is especially important with the receiver/drier.

Additionally, when caps are removed for assembly, **BE CAREFUL!** Some components are shipped under pressure with dry nitrogen.

Evacuate the System for 35-45 Minutes: Ensure that system components (Drier, compressor, evaporator and condenser) are at a temperature of at least 85°F. On a cool day, the components can be heated with a heat gun **or** by running the engine with the heater on before evacuating. Leak check and charge to specifications.

Bolts Passing Through Cowl and/or Firewall:

To ensure a watertight seal between the passenger compartment and the vehicle exterior, for all bolts passing through the cowl and/or firewall, Vintage Air recommends coating the threads with silicone prior to installation.

Heater Hose (not included with this kit):

Heater hose may be purchased from Vintage Air (Part#31800-VUD) or your local parts retailer. Routing and required length will vary based on installer preference.



www.vintageair.com

Important Wiring Notice—Please Read

Some vehicles may have had some or all of their radio interference capacitors removed. There should be a capacitor found at each of the following locations:

- 1. On the positive terminal of the ignition coil.**
- 2. If there is a generator, on the armature terminal of the generator.**
- 3. If there is a generator, on the battery terminal of the voltage regulator.**

Most alternators have a capacitor installed internally to eliminate what is called “whining” as the engine is revved. If whining is heard in the radio, or just to be extra cautious, a radio interference capacitor can be added to the battery terminal of the alternator.

It is also important that the battery lead is in good shape and that the ground leads are not compromised. There should be a heavy ground from the battery to the engine block, and additional grounds to the body and chassis.

If these precautions are not observed, it is possible for voltage spikes to be present on the battery leads. These spikes come from ignition systems and charging systems, and from switching some of the vehicle’s other systems on and off. Modern computer-operated equipment can be sensitive to voltage spikes on the power leads, which can cause unexpected resets, strange behavior and/or permanent damage.

Vintage Air strives to harden our products against these types of electrical noise, but there is a point where a vehicle’s electrical system can be degraded so much that nothing can help.

Radio interference capacitors should be available at most auto and truck parts suppliers. They typically are cylindrical in shape, a little over an inch long and a little over a half-inch in diameter, and they have a single lead coming from one end of the cylinder with a terminal on the end of the wire, as well as a mounting clip which is screwed into a good ground on the vehicle. The specific value of the capacitance is not too significant in comparison to ignition capacitors that are matched with the coil to reduce pitting of the points.

- Care must be taken, when installing the compressor lead, not to short it to ground. The compressor lead must not be connected to a condenser fan or to any other auxiliary device. Shorting to ground or connecting to a condenser fan or any other auxiliary device may damage wiring or the compressor relay, and/or cause a malfunction.
- When installing ground leads on Gen 5 systems, the blower control ground and ECU ground must be connected directly to the negative battery post.
- For proper system operation, the heater control valve must be connected to the ECU.



www.vintageair.com

Engine Compartment Disassembly

NOTE: Before starting the installation, check the function of the vehicle (horn, lights, etc.) for proper operation, and study the instructions, illustrations, photos & diagrams.

Perform the following:

1. Disconnect the battery.
2. Remove the battery and the battery tray (retain).
3. Drain the radiator.
4. Remove the radiator (retain). **NOTE: Removal of radiator is only needed if installing a condenser kit.**
5. Remove the passenger-side front wheel, then remove the inner fender well (See Figure 1, below).
6. Remove the OEM blower assembly (discard).
7. Remove the OEM heater hoses (discard) (See Figure 1, below).
8. Remove the OEM heater wiring.

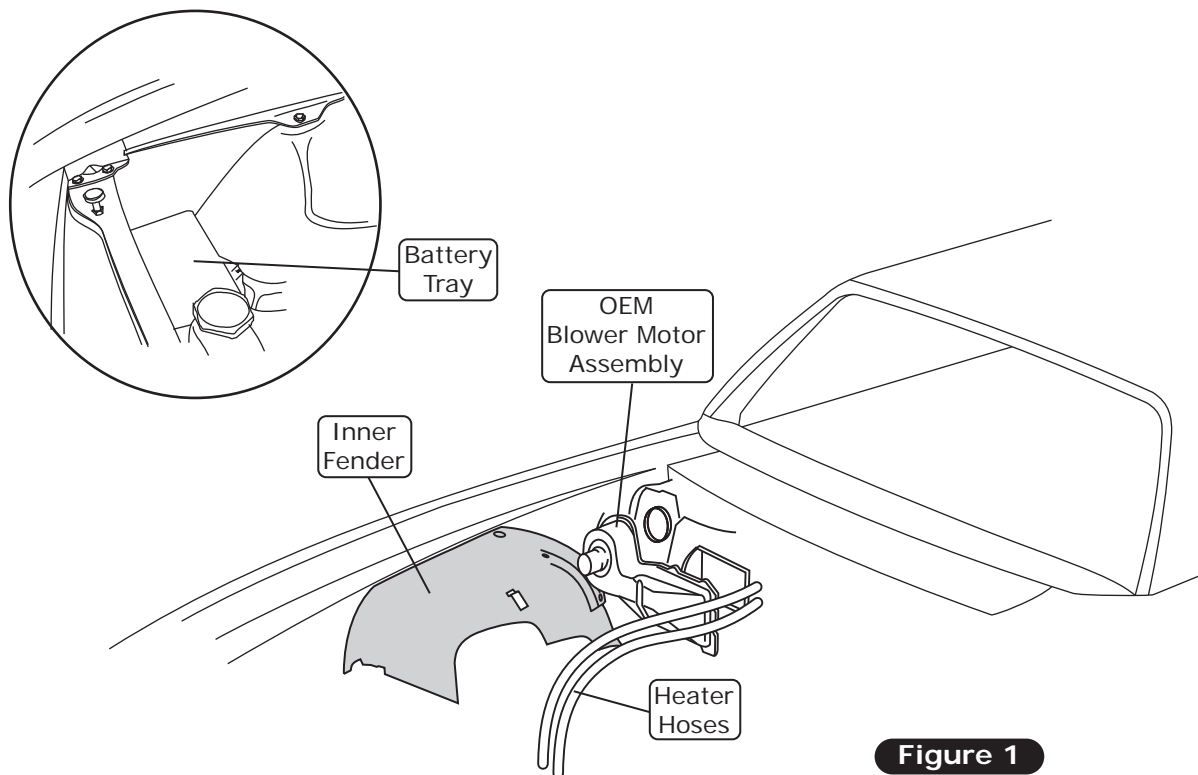

Figure 1

Condenser Assembly and Installation

1. Refer to separate instructions included with the condenser kit to install the condenser.
2. Binary switch installation (Refer to condenser instructions).

Compressor and Brackets

1. Refer to separate instructions included with the bracket kit to install the compressor bracket.



www.vintageair.com

Passenger Compartment Disassembly

Perform the following:

1. Remove the glove box door (retain) (See Figure 1, below).
2. Remove the glove box (discard) (See Figure 1, below).
3. Disconnect all wires and cables from the OEM heater assembly (discard).
4. Disconnect all wires and cables from the control panel and radio.
5. Disconnect the light from behind the control panel. Remove the (2) mounting screws, then remove the control panel from the dash (See Figure 1, below).
6. Disconnect the speedometer cable and wiring to the switches.
7. Remove the (5) mounting bolts on the bottom of the dash.
8. Remove the steering column hardware, then lower the column.
9. Remove (9) dash mounting screws.
10. Remove the dashboard from the vehicle.
11. Remove the OEM dashboard support bracket and hardware (discard).
12. Remove the OEM defrost duct assembly (discard).
13. Remove the OEM heater assembly (discard) (See Figure 1, below).
14. Remove the passenger-side kick panel/fresh air door assembly.

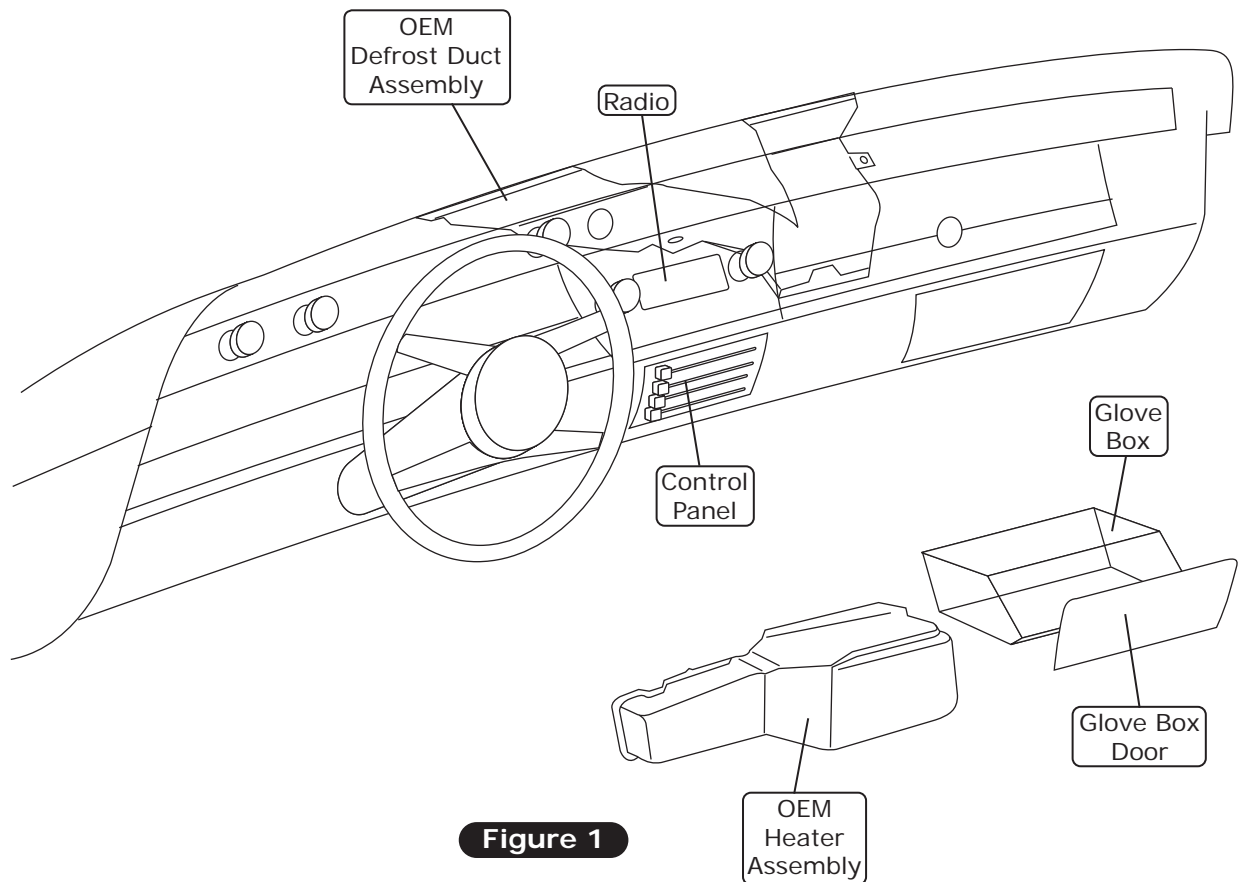

Figure 1



www.vintageair.com

Firewall Modification

NOTE: A firewall modification is required for the firewall cover and drain hose installation.

1. Remove or flatten the edges of the firewall opening (See Photos 1 and 2, below).

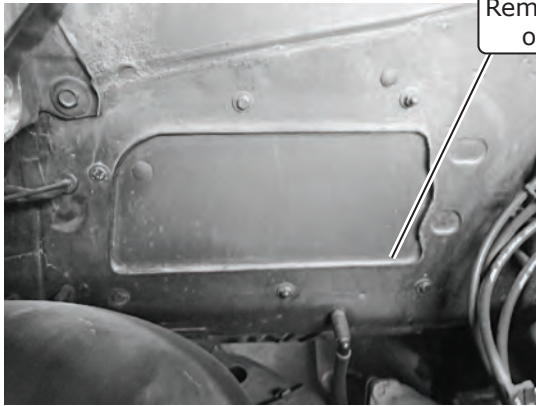

Photo 1

Remove or flatten edges of firewall opening

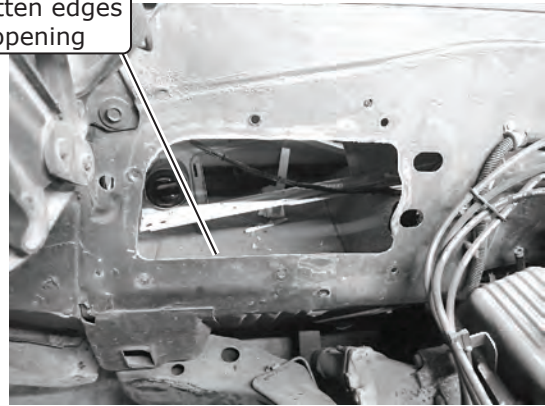

Photo 2

Firewall Cover Preparation

1. Install (4) 1/4-20 x 3/4" black serrated flange bolts with (4) 1/4" pushnut bolt retainers onto the firewall cover (See Photos 1 and 2, below).

(4) 1/4-20 x 3/4" Serrated Flange Black Bolts

(4) 1/4" Pushnut Bolt Retainers

Firewall Cover 643209

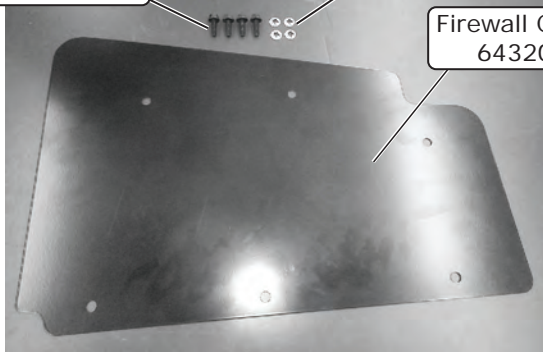

Photo 1

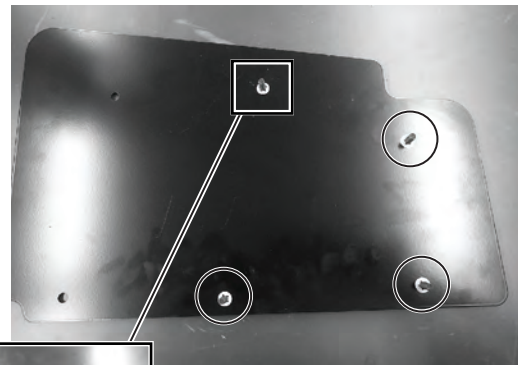

Photo 2

Install (4) 1/4-20 x 3/4" black serrated flange bolts with (4) 1/4" pushnut bolt retainers onto firewall cover



www.vintageair.com

Firewall Cover Installation and Insulation

NOTE: For proper system operation, Vintage Air recommends using Dynaliner (461500-VIP) heatblocking insulation in the area around the evaporator module (firewall, kick panel, inner cowl and firewall covers). Due to tight clearance for the evaporator module, between the firewall and dash, Vintage Air recommends an insulation thickness of no more than 1/8".

1. Apply silicone/seam sealer to the mating surface of the firewall cover (See Photo 1, below).
2. Install the firewall cover onto the firewall (See Photo 2, below), then secure it using (4) 1.625" O.D. x .281" I.D. washers and (4) 1/4-20 nuts with star washers (See Photo 3, below).
3. Clean the firewall and necessary areas, then apply heat-blocking insulation.

Apply silicone/seam sealer to mating surface of firewall cover

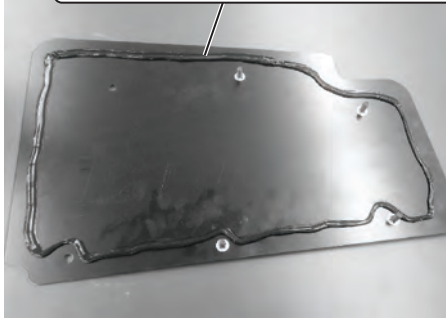

Photo 1

Install firewall cover onto firewall



Photo 2

Secure firewall cover using (4) 1.625" O.D. x .281" I.D. washers and (4) 1/4-20 nuts with star washers

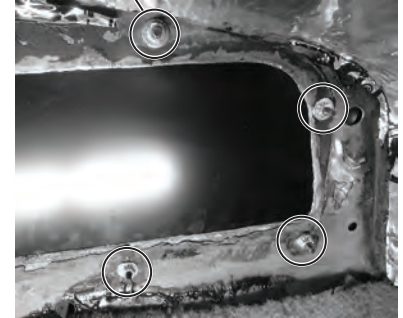
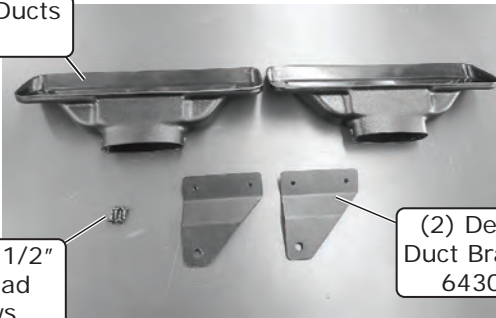

Photo 3

Defrost Duct Preparation & Installation

1. Gather (2) defrost ducts, (2) defrost duct brackets and (4) #8 x 1/2" pan head screws (See Photo 1, below).
2. Place the defrost duct bracket onto the defrost duct (See Photo 2, below). Mark and drill (2) small pilot holes (See Photo 3, below), then install the (2) #8 x 1/2" pan head screws (See Photo 4, below). Repeat the process for the second defrost duct.

(2) Defrost Ducts
627021



(4) #8 x 1/2"
Pan Head
Screws

(2) Defrost
Duct Brackets
643058

Photo 1

Place defrost
duct bracket onto
defrost duct

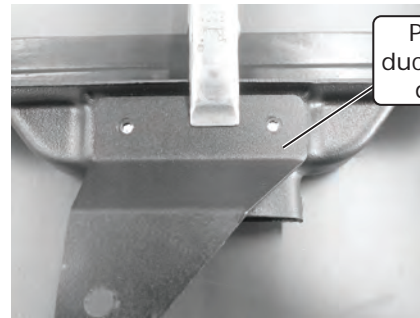

Photo 2

Mark and drill (2) small pilot holes

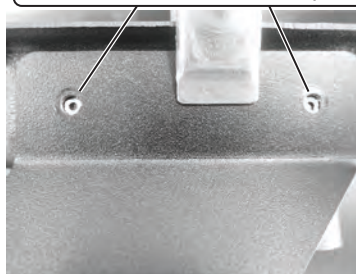

Photo 3

Install (2) #8 x 1/2"
pan head screws



Photo 4



www.vintageair.com

Defrost Duct Preparation & Installation (Cont.)

3. Install the defrost ducts under the dash, aligning them with the OEM openings (See Photo 5, below). Secure the driver- and passenger-side defrost ducts to the cowl using (2) #14 x 3/4" washer head screws (See Photos 5, 6 and Figure 1, below). **NOTE: On 1966 models, the driver-side defrost duct installs behind the steering column bracket and is secured using the steering column OEM bolt as shown in Figure 1a, below.**

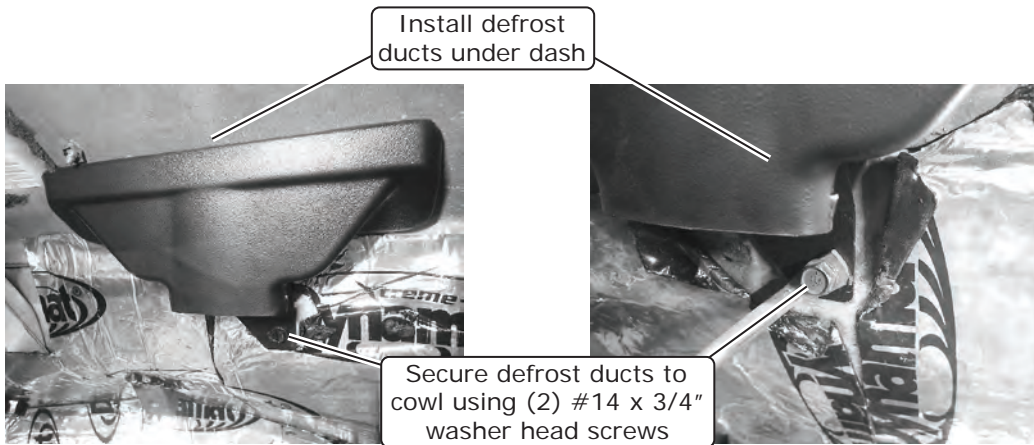
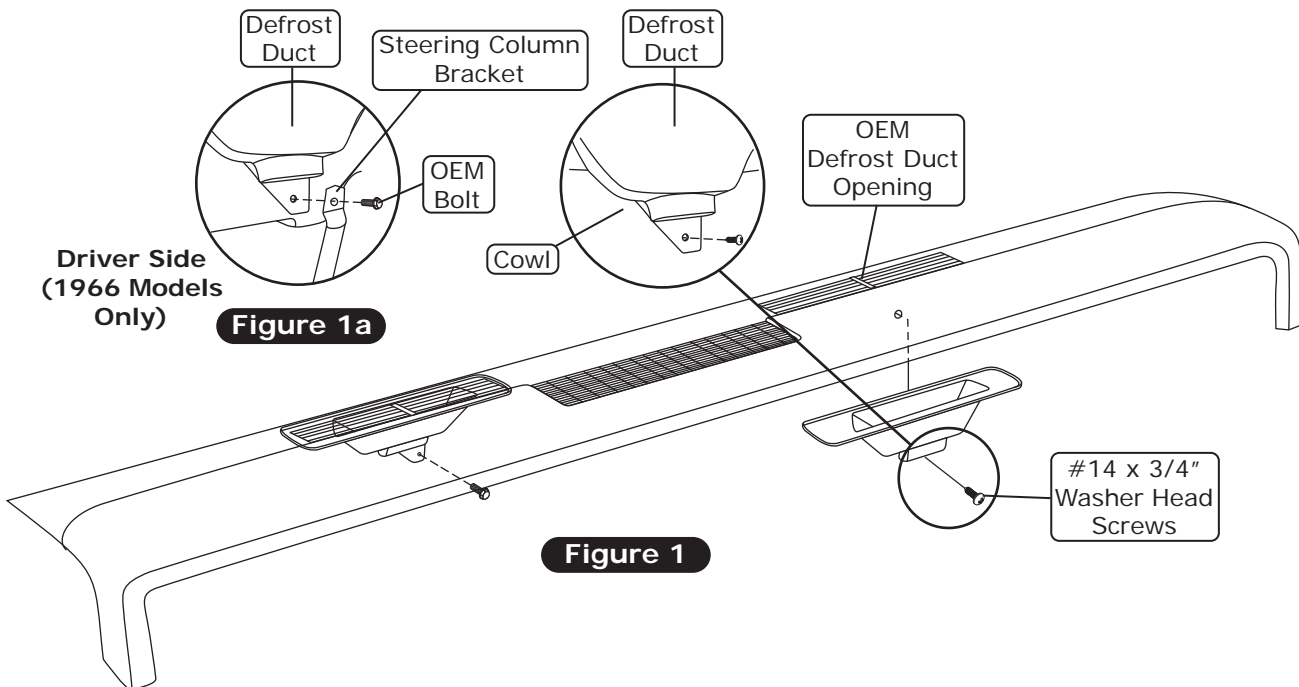

Photo 5

Photo 6



Driver Side
(1966 Models
Only)

Figure 1a

Figure 1



www.vintageair.com

1966 Chevelle Kick Panel Modification

1. Remove the kick panel.
2. Remove the kick panel fresh air door assembly by removing (5) OEM screws (See Figure 1, below).
3. Disconnect the pull cable assembly from under the dash (discard) (See Figure 1, below).
4. Cut out the kick panel modification template provided on Page 40.
5. Align the template onto the back side of the kick panel as shown in Figure 2, below.
6. Cut out the kick panel grille as shown in Figure 2, below.
7. Drill (5) 3/16" holes into the kick panel (See Figure 2, below).

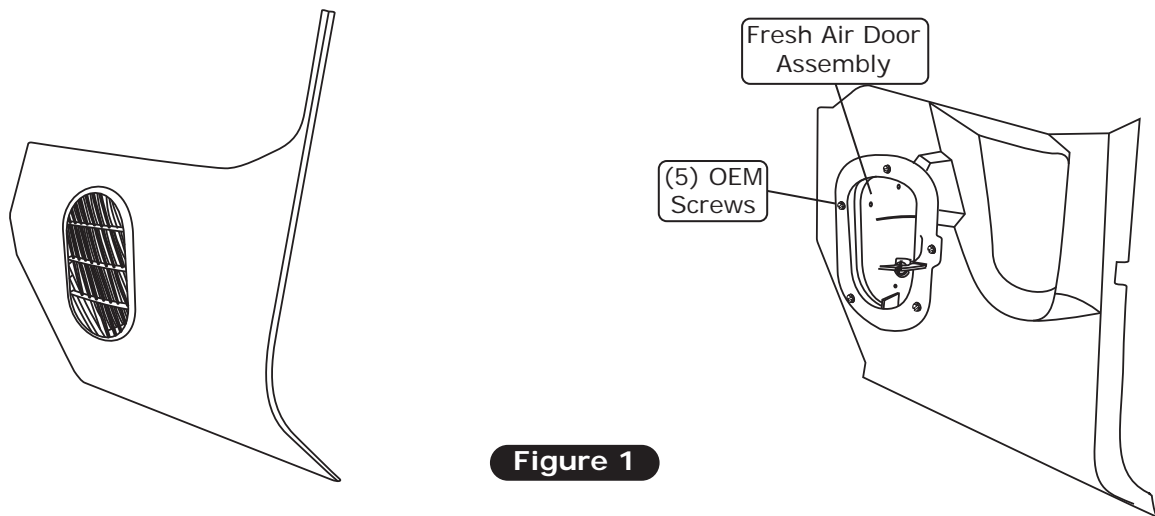

Figure 1

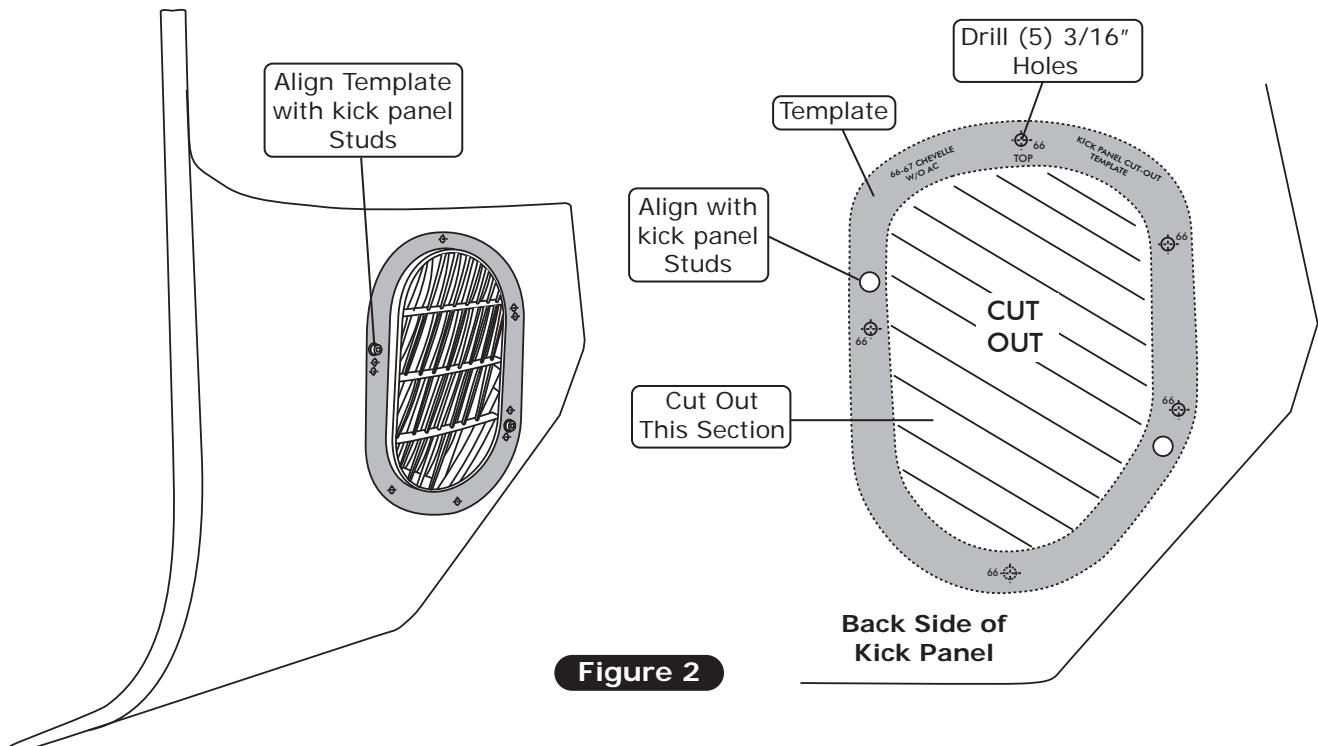

Figure 2



www.vintageair.com

1967 Chevelle Kick Panel Modification

1. Remove the kick panel grille (discard) (See Figure 1, below).
2. Remove the kick panel by removing (5) OEM screws from the fresh air door assembly (See Figure 1, below).
3. Disconnect the pull cable assembly from the kick panel (discard) (See Figure 1, below).
4. Install a 1/2" plastic plug to fill the hole left from the removal of the pull cable assembly (See Figure 2, below).
5. Cut out the kick panel modification template provided on Page 41.
6. Place template onto kick panel and cut out fresh air door assembly as shown in Figures 2 & 2a, below.

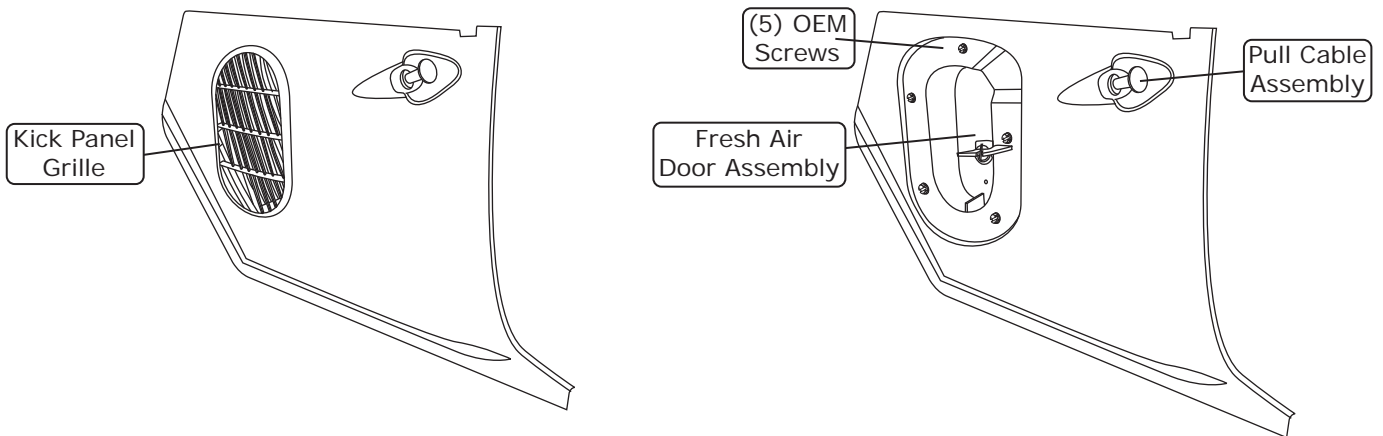

Figure 1

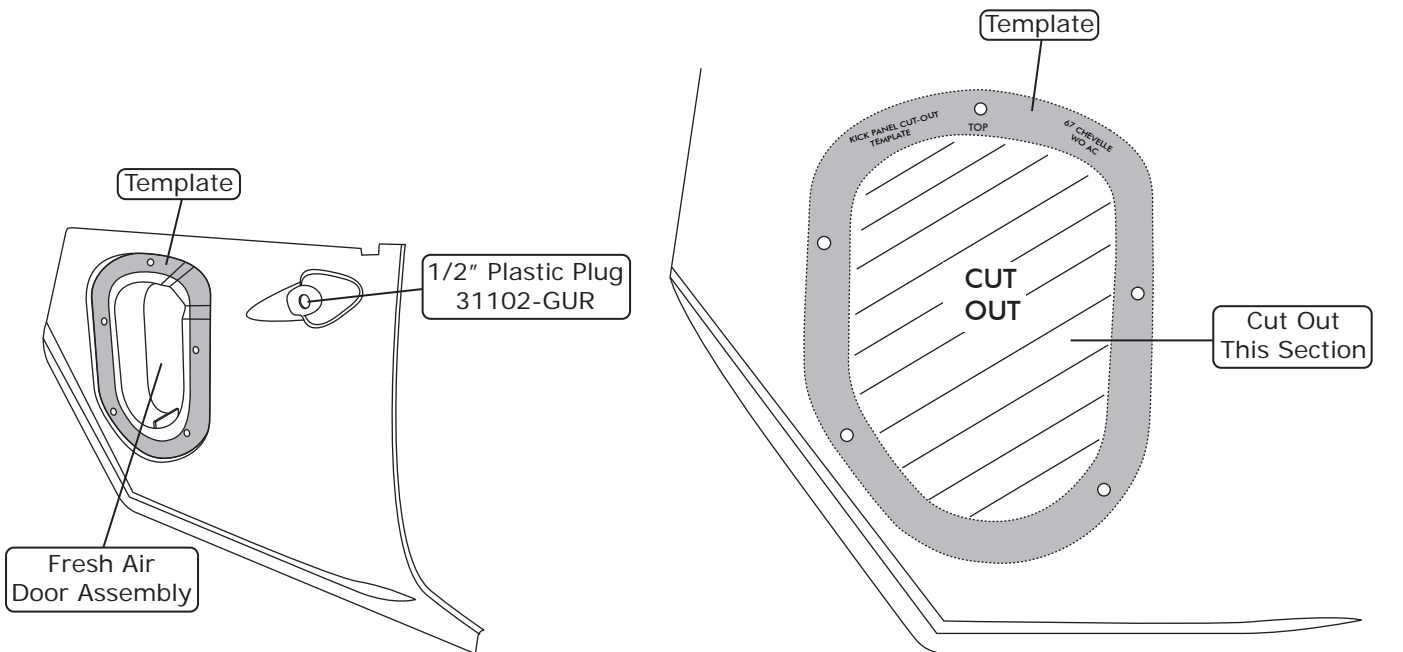

Figure 2

Figure 2a



www.vintageair.com

Driver- and Passenger-Side Louver Installation

Perform the following on a workbench:

1. Cut out the template provided on Page 14. Place the driver-side template onto the dash, by aligning the left side of the template against the edge of the dash, then align the bottom of the template to the bottom of the dash as shown in Figure 1, below.
2. Cut out the template provided on Page 15. Place the passenger-side template onto the dash, by aligning the right side of the template against the edge of the dash, then align the bottom of the template to the bottom of the dash as shown in Figure 1, below.
3. Once the templates are aligned correctly, use a center punch to mark the holes on the dash. Remove the templates. Use a 3" hole saw to cut the holes in the dash (See Figure 1, below).
4. Install louvers into the dash as shown in Figure 1a, below.

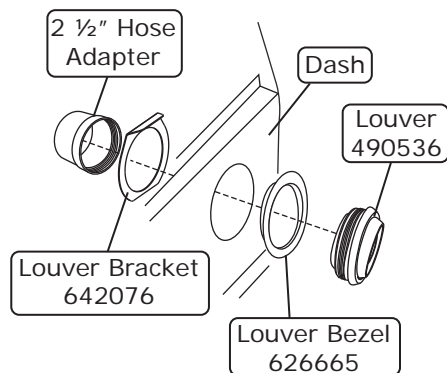
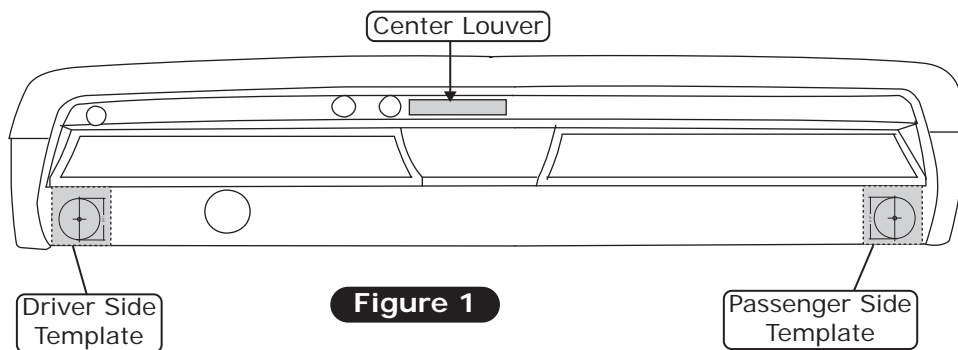



www.vintageair.com

Driver-Side Louver Template

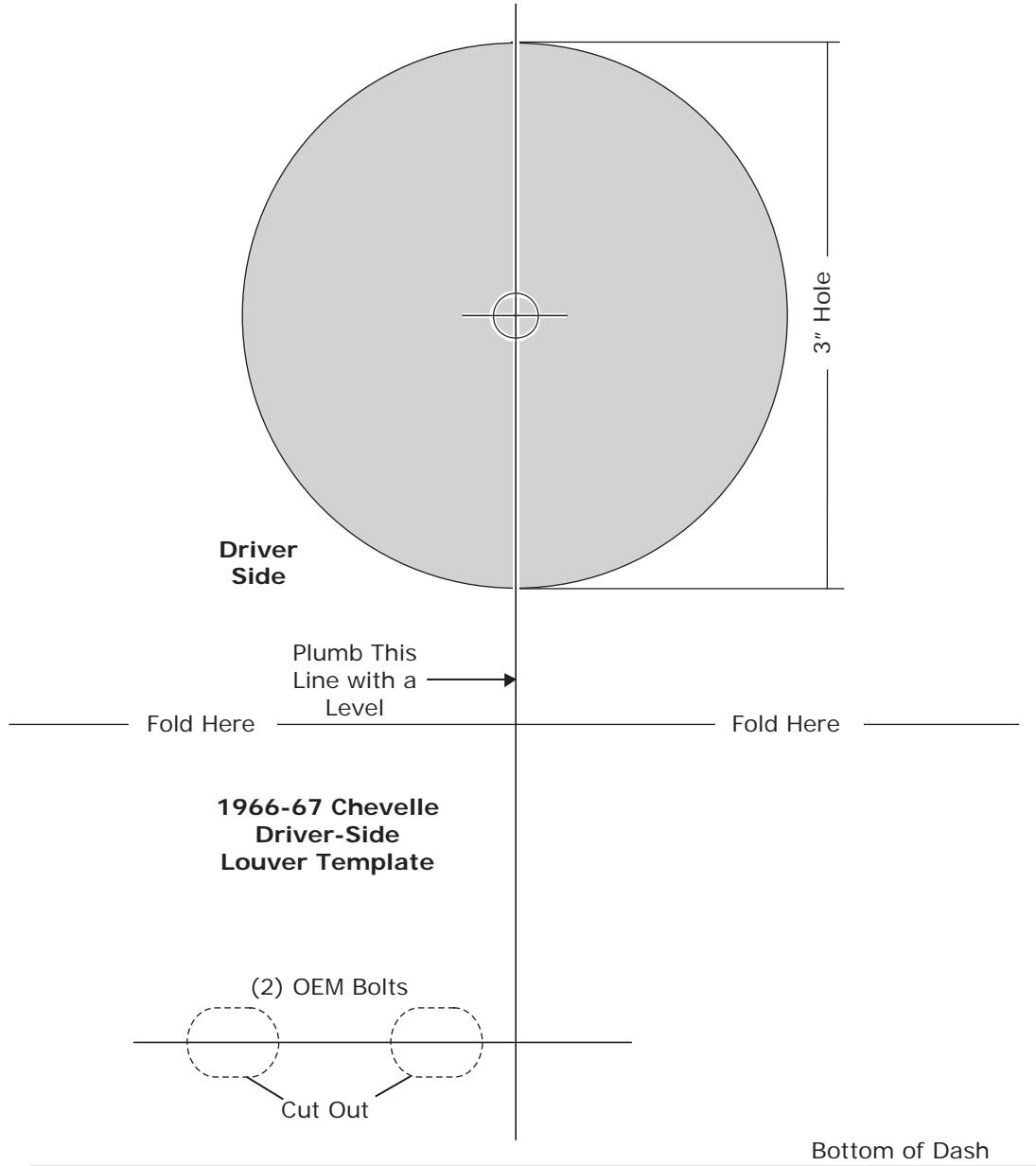

NOTE: Due to printing variances, measure the line below before using this template. If template is scaled properly, the line should measure 6 inches.

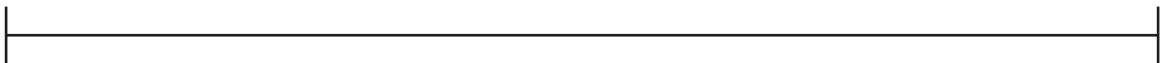



www.vintageair.com

Passenger-Side Louver Template

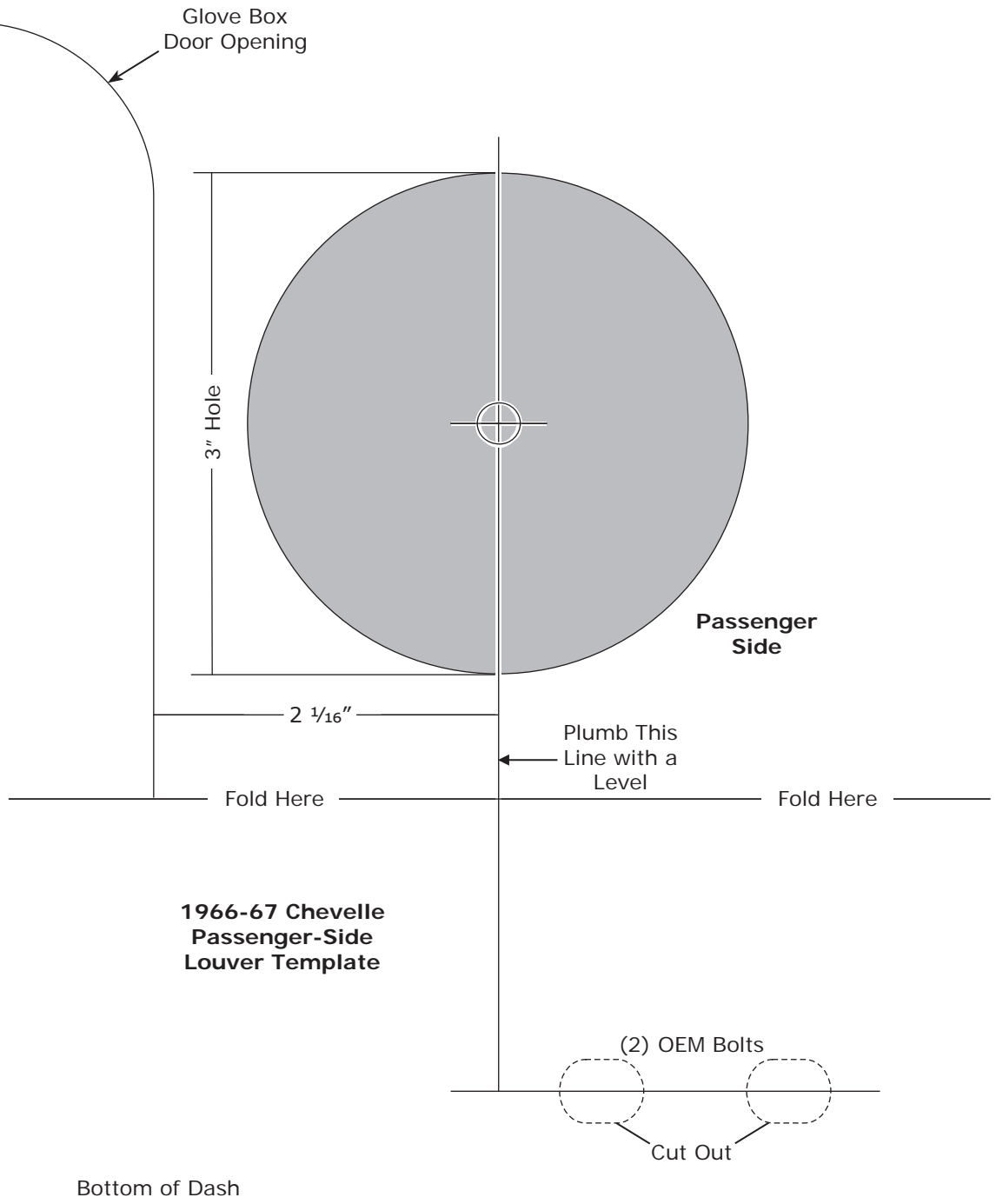

NOTE: Due to printing variances, measure the line below before using this template. If template is scaled properly, the line should measure 6 inches.

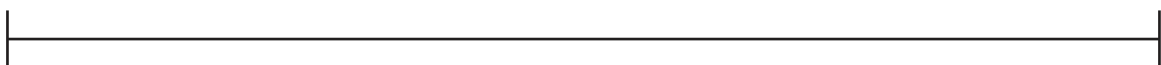



www.vintageair.com

Center Louver Installation

1. Remove the trim panel from the dashboard (See Photo 1, below). **NOTE: Use masking tape to prevent damage to painted areas.**
2. Place the center dash vent template onto the trim panel as shown in Photo 2, below.
3. Remove the center area of the trim panel (See Photo 3, below).
4. Place the trim panel onto the dashboard (See Photo 4, below). Using the opening, mark the area of the dash to be removed (See Photo 4, below).
5. Remove the trim panel and line up the center dash vent template with the area to be removed (See Photo 5, below).
6. Mark and drill (2) holes using a 1/8" drill bit (See Photos 6 and 7, below).
7. Remove the marked area of the dash (See Photo 8, below).

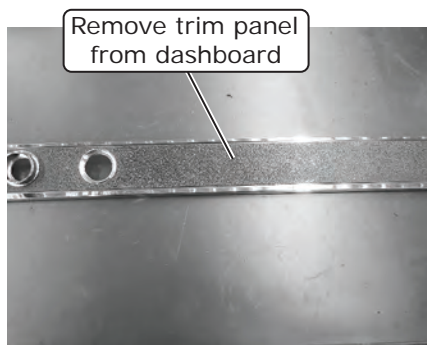

Photo 1

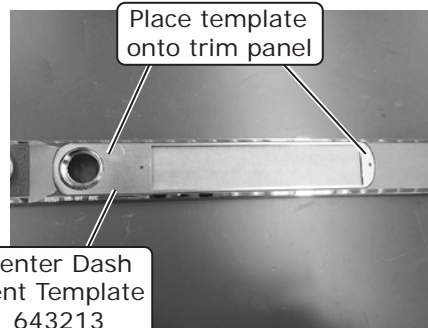

Photo 2



Photo 3

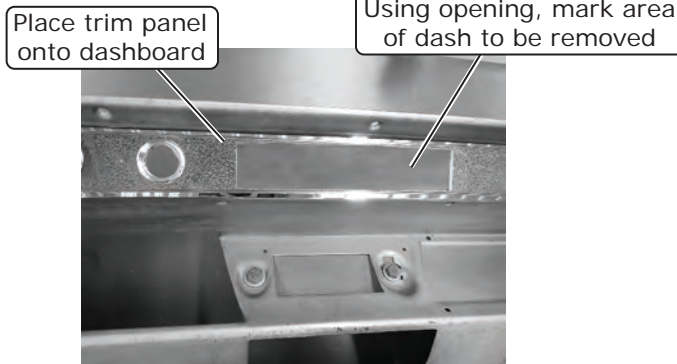

Photo 4

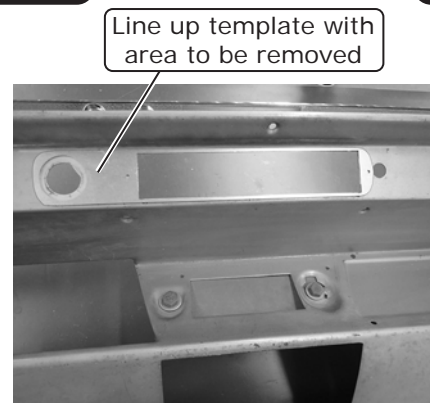

Photo 5

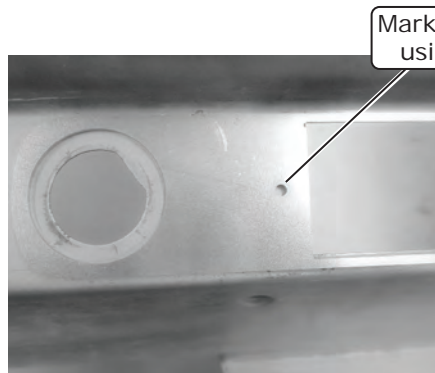

Photo 6

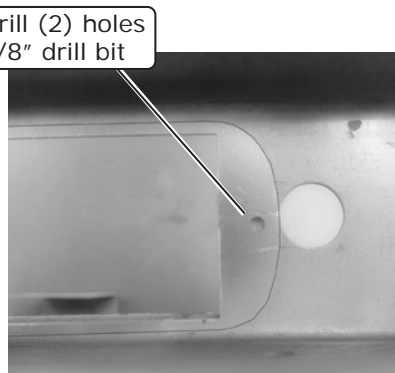

Photo 7

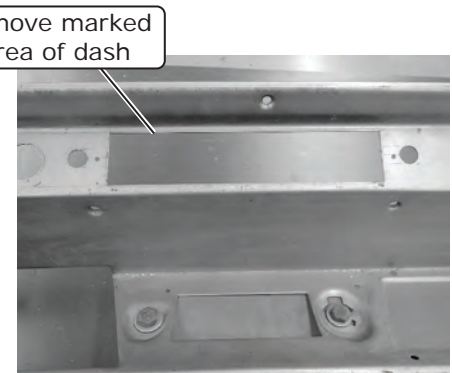

Photo 8



www.vintageair.com

Center Louver Installation (Cont.)

8. Modify (2) louvers by trimming the upper and lower clips as shown in Photos 9 and 10, below.
9. Insert press-in studs into the previously drilled 1/8" holes (See Photos 11 and 12, below).
10. Using (2) 4-40 nuts with star washers, snug down the press-in studs until flush, then remove the nuts (See Photo 13, below).
11. Install the 1/8" x 1/2" x 8" sealing foam to the dash, above the louver opening (See Photo 14, below).
NOTE: Install duct hose onto the center louver hose adapter assembly at this time.
12. Install the center louver hose adapter assembly over the press-in studs and secure using the 4-40 nuts with star washers (See Photos 15 and 16, below).

3.875" x 1.562"
Black Louver
493560

Modify (2) louvers by trimming
upper and lower clips

3.875" x 1.562"
Black Louver
493560

**NOTE: Do not cut more
than shown in photos.**

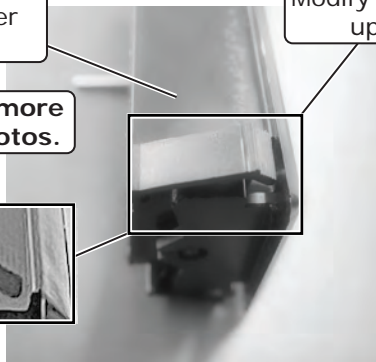
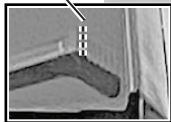

Photo 9

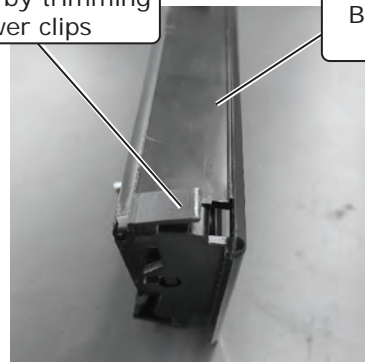

Photo 10

Insert press-in studs into
previously drilled 1/8" holes

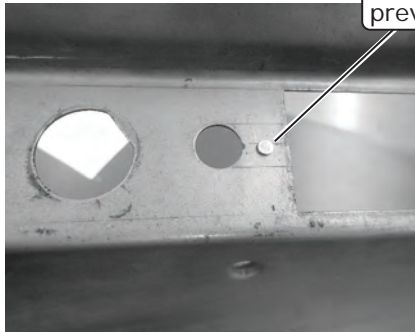

Photo 11

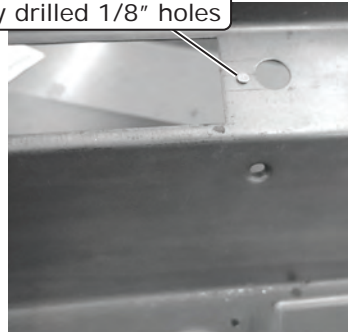

Photo 12

Using 4-40 nut with star washer,
snug down press-in studs until
flush, then remove nut

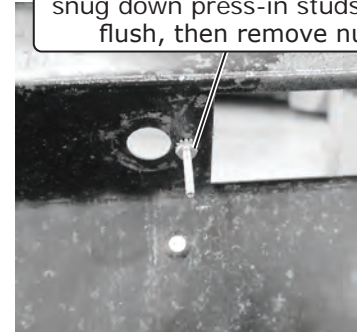

Photo 13

Install sealing foam
to dash above
louver opening

1/8" x 1/2" x 8"
Sealing Foam

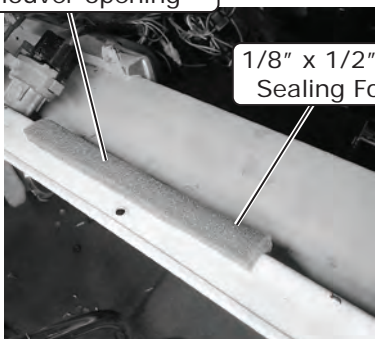

Photo 14

Install center
louver hose
adapter
assembly over
press-in stud
and secure
using 4-40 nut
with star washer

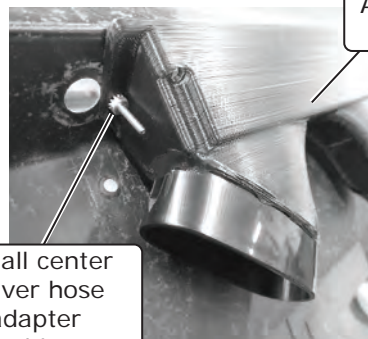

Photo 15

Center Louver Hose
Adapter Assembly
627023

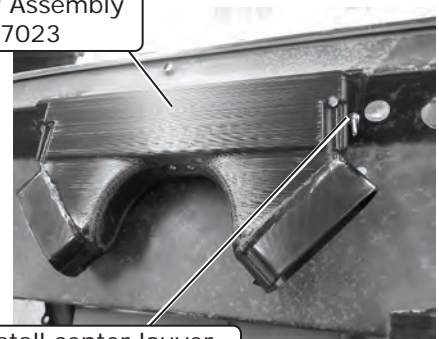

Photo 16

Install center louver
hose adapter
over press-in stud and
secure using 4-40 nut
with star washer



www.vintageair.com

Center Louver Installation (Final)

- 13. Reinstall the trim panel onto the dashboard (See Photo 17, below).
- 14. Install the modified louvers (See Photo 18, below).

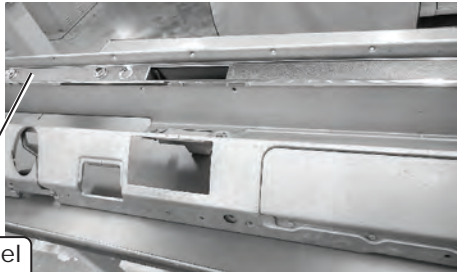

Reinstall trim panel onto dashboard

Photo 17

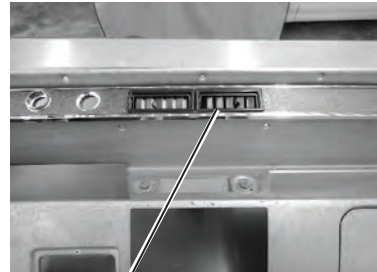

Install modified louvers

Photo 18

Alternate Mounting Procedure

NOTE: Remove OEM speaker (if equipped), and reinstall after hose adapter is attached.

1. Remove the trim panel from the dashboard (See Photo 1, below). **NOTE: Use masking tape to prevent damage to painted areas.**
2. Place the metal template onto the trim panel as shown in Photo 2, below.
3. Remove the center area of the trim panel (See Photo 3, below).
4. Place the trim panel onto the dashboard, using the opening mark the area of the dash to be removed (See Photo 4, below).
5. Remove the trim panel and line up the template with the area to be removed (See Photo 5, below).
6. Remove the marked area of the dash (See Photo 6, below).

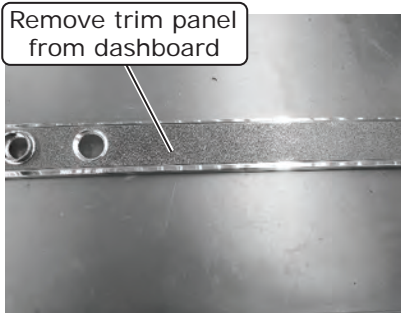

Remove trim panel from dashboard

Photo 1

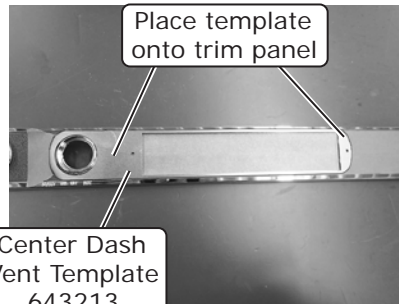

Place template onto trim panel

Center Dash Vent Template 643213

Photo 2

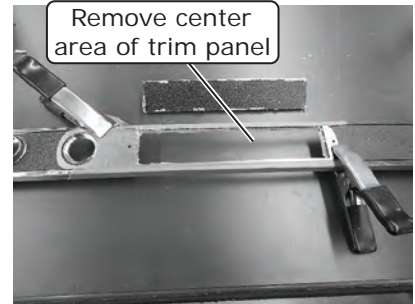

Remove center area of trim panel

Photo 3

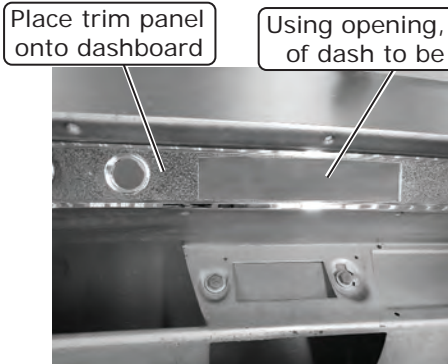

Place trim panel onto dashboard

Using opening, mark area of dash to be removed

Photo 4

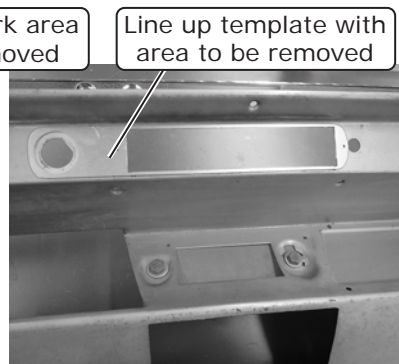

Line up template with area to be removed

Photo 5

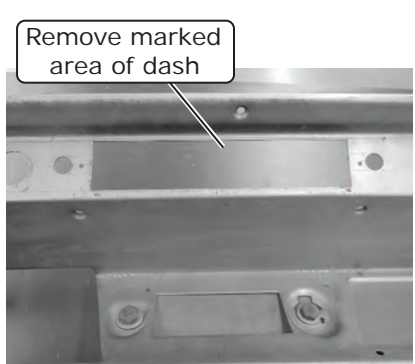

Remove marked area of dash

Photo 6



www.vintageair.com

Alternate Mounting Procedure (Cont.)

7. Modify (2) louvers by trimming the upper and lower clips as shown in Photos 7 and 8, below.
8. Install (2) lengths of duct hose onto the louver adapter at this time.
9. Reinstall the trim panel onto the dashboard (See Photo 9, below).
10. Install louver adapter over the dash opening. Reinstall the OEM bracket and OEM screw to secure the adapter to the dash (See Figure 1, below).

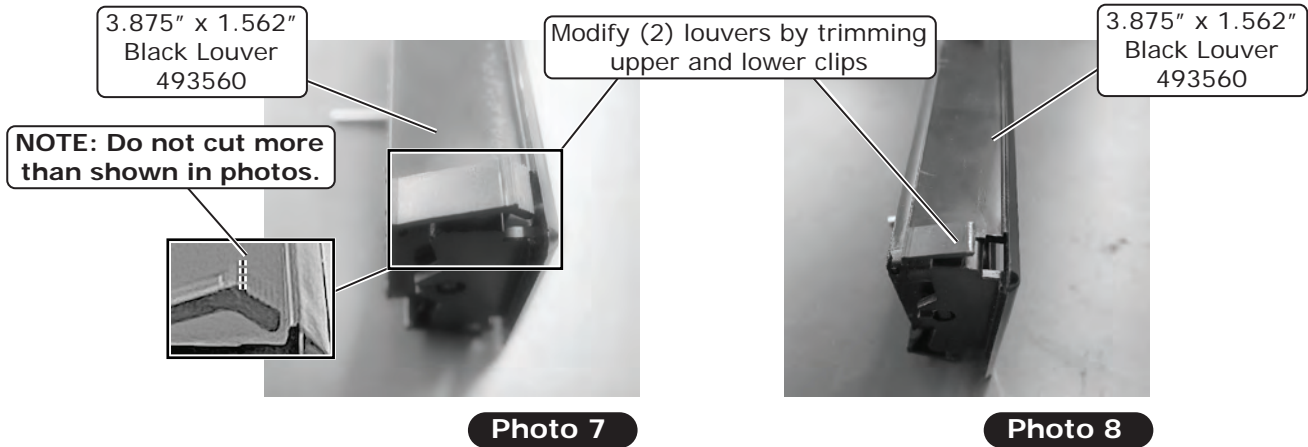

Photo 7

Photo 8

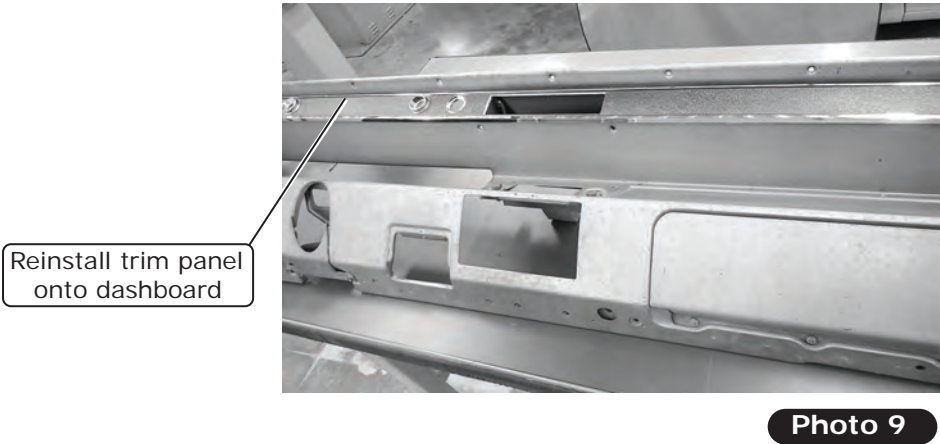

Photo 9

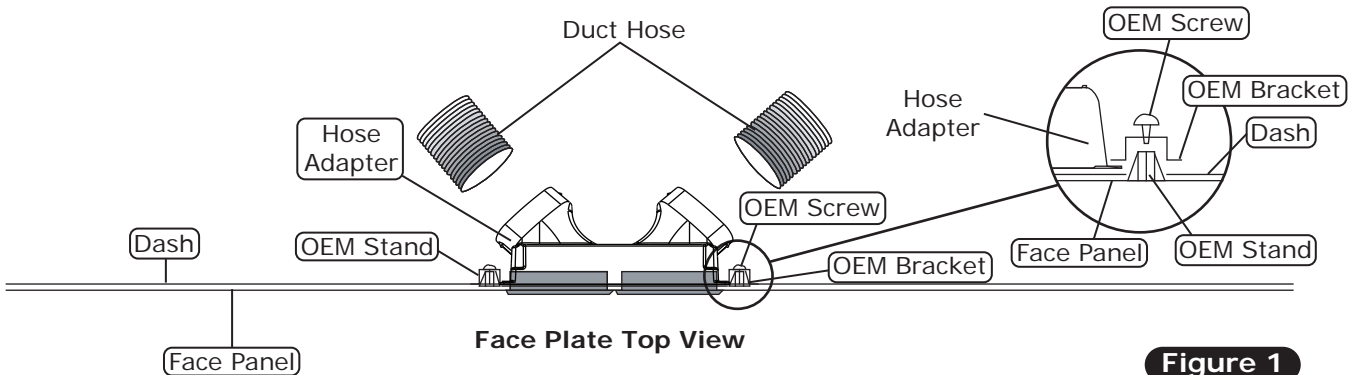

Figure 1



www.vintageair.com

Fresh Air Cap & Kick Panel Cover Preparation

1. Install (4) large grommets and a 7/8" grommet into the fresh air cap (See Photo 1, below).
2. On the inside of the fresh air cap, the letter "T" indicates the top mounting hole for the firewall.
3. From the center of the bottom-left hole in the kick panel fresh air cap, measure 1 1/2" down. Mark and drill a 5/8" hole for the 7/8" grommet (See Photos 2 and 3, below).
4. Install (4) large grommets and a 7/8" grommet into the kick panel fresh air cap (See Photo 4, below).

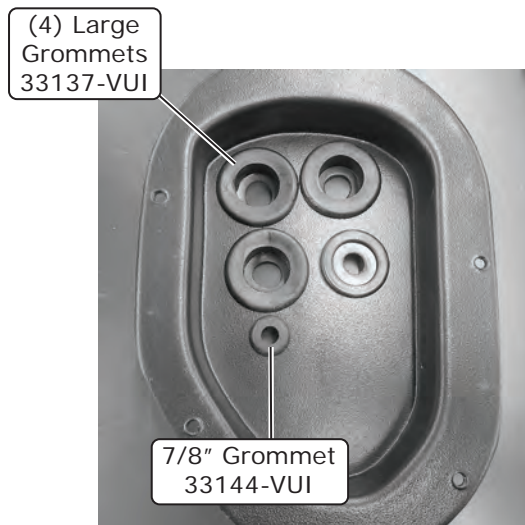
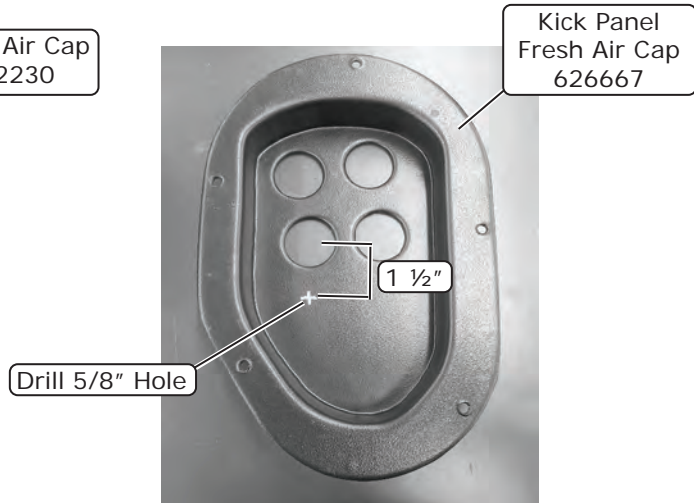
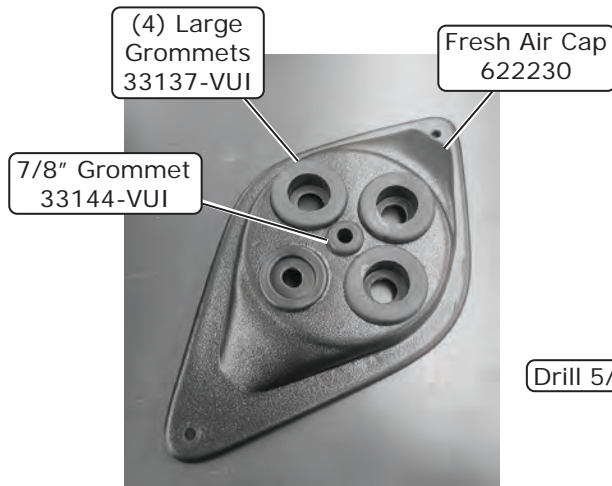



www.vintageair.com

Lubricating O-rings

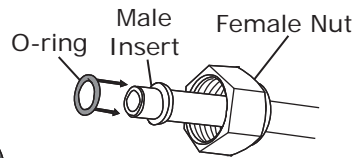
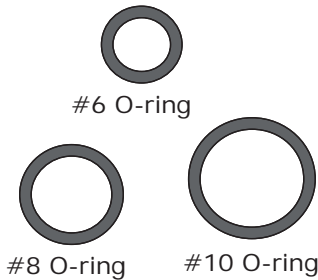

For a proper seal of fittings: Install supplied O-rings as shown and lubricate with refrigerant oil.

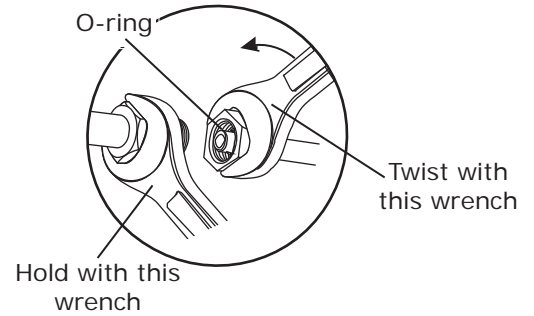
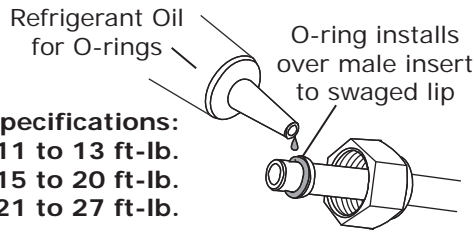

NOTE: Standard torque specifications:
#6: 11 to 13 ft-lb.
#8: 15 to 20 ft-lb.
#10: 21 to 27 ft-lb.

Properly Seated O-ring Land

When installing a hardline or A/C hose fitting onto the evaporator module, ensure the O-ring land is seated properly (See Photo 1, below). An improperly seated O-ring land (See Photo 2, below) can cause a leak. To properly install the fitting, slide the hardline or A/C hose nut back to expose the O-ring land and seat it onto the evaporator module fitting. Then, slide the hardline or A/C hose nut forward and thread it onto the evaporator module fitting, ensuring the O-ring land does not move or lift.

Properly Seated O-ring Land



Photo 1

Improperly Seated O-ring Land

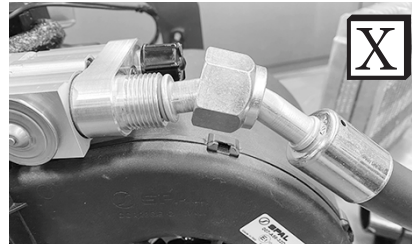

Photo 2

NOTE: Photos shown are for reference only. Fittings may vary depending on kit received.



www.vintageair.com

Evaporator Module Preparation

Perform the following on a workbench:

1. Install (3) 1/2" plastic plugs into the rear mounting holes of the module (See Photos 1 and 2, below).
NOTE: These mounting positions will not be used in this application.
2. Remove the caps and rubber inserts from the heater fittings. With (2) properly lubricated #10 O-rings (See Lubricating O-rings, Page 21), install the (2) 45° heater hardlines (See Photo 3, below).
3. Using (4) #10 x 5/8" screws, install the firewall assembly bracket onto the evaporator module (See Photos 4 and 5, below).
4. Install (2) 1/4-20 x 1 1/2" full-threaded studs into the evaporator bracket (See Photo 6, below).
5. Using (2) spring clips, install the floor plenum onto the front of the evaporator module (See Photo 7, below).
6. Using (2) spring clips, install the 2-vent plenum onto the rear of the evaporator module (See Photo 8, below).

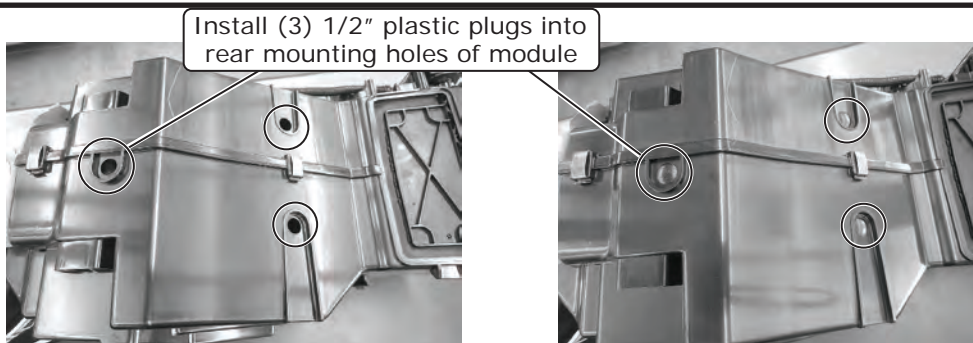

Photo 1

Photo 2

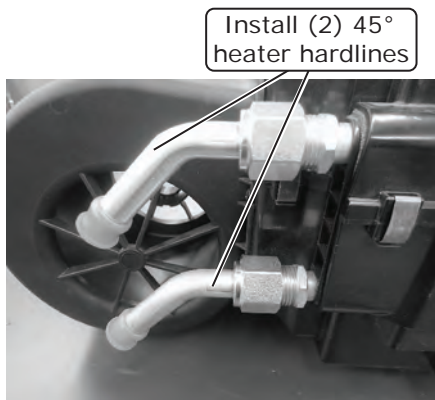
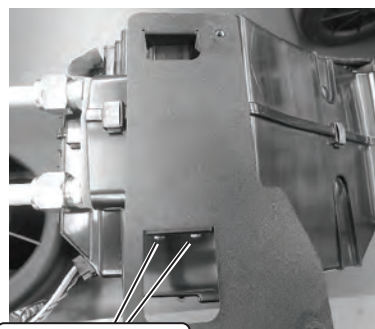

Photo 3



(2) #10 x 5/8" Screws

Photo 4

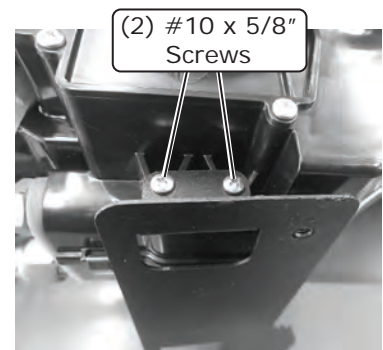

Photo 5

Install (2) 1/4-20 x 1 1/2" full-threaded studs

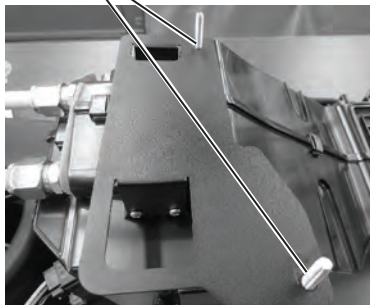

Photo 6

Using (2) spring clips, install floor plenum

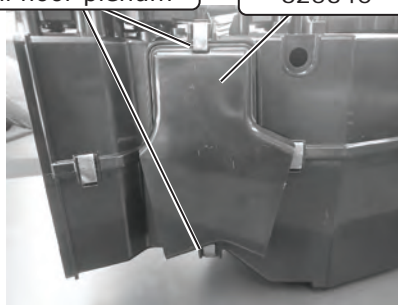
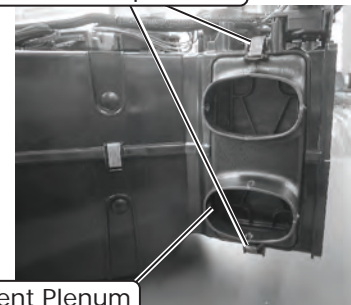

Photo 7

Using (2) spring clips, install floor plenum



2-Vent Plenum 629905

Photo 8



www.vintageair.com

Evaporator Module Preparation (Cont.)

7. Using (4) spring clips, install the dash plenum onto the evaporator module (See Photos 9 and 10, below).

Using (2) spring clips, install dash plenum

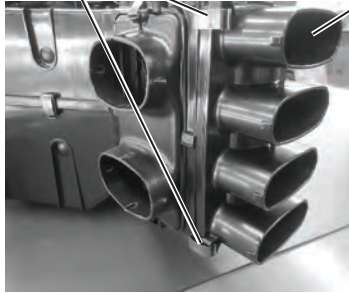

Photo 9

Dash Plenum 625330

Using (2) spring clips, install dash plenum

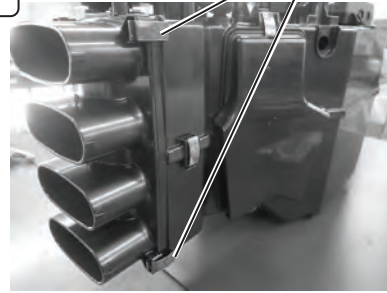
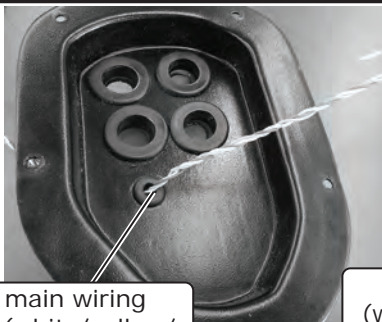

Photo 10

Wiring Installation

1. Locate the heater control valve plug on the main wiring harness (white/yellow/purple). Route it through the 7/8" wiring grommet on the kick panel fresh air cap (See Photo 1, below) and into the kick panel opening. Then, through the wiring grommet on the fresh air cap (See Photo 2, below) and into the engine compartment.
2. Route the red, white and blue wires from the main harness through the 7/8" wiring grommet on the kick panel fresh air cap (See Photo 3, below) and into the kick panel opening. Then, route the wires through the wiring grommet on the fresh air cap and into the engine compartment (See Photo 4, below).
3. Leave approximately 12" of wiring between the kick panel fresh air cap and relay.
4. Place the evaporator module on the passenger-side floorboard.
5. Route the heavy gauge orange and white wires through the wiring grommet on the kick panel fresh air cap (See Photo 5, below) and into the kick panel opening. Then, through the wiring grommet on the fresh air cap and into the engine compartment (See Photo 6, below).



Route main wiring harness (white/yellow/purple) through 7/8" wiring grommet on kick panel fresh air cap

Photo 1



Route main wiring harness (white/yellow/purple) through wiring grommet on fresh air cap

Photo 2

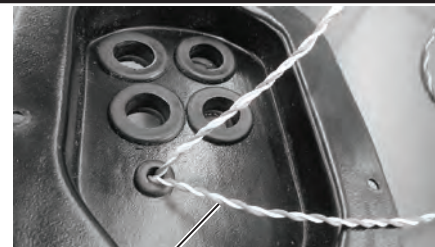

Route red, white and blue wires from main harness through 7/8" wiring grommet on kick panel fresh air cap

Photo 3

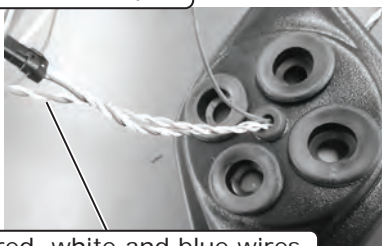

Route red, white and blue wires from main harness through 7/8" wiring grommet on fresh air cap

Photo 4



Route heavy gauge orange and white wires through 7/8" wiring grommet on kick panel fresh air cap

Photo 5



Route heavy gauge orange and white wires through 7/8" wiring grommet on fresh air cap

Photo 6



www.vintageair.com

Wiring Installation (Cont.)

6. Connect the blower speed controller plug into the main wiring harness plug (orange and green wires) (See Photo 7, below).

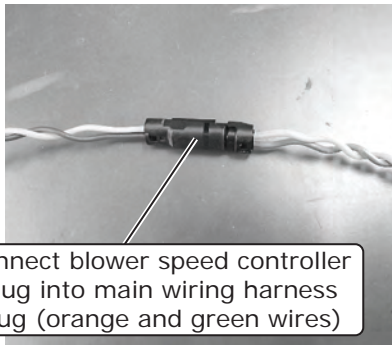

Connect blower speed controller plug into main wiring harness plug (orange and green wires)

Photo 7

Kick Panel Fresh Air Cap Installation

1. Route the A/C and heater hoses through the kick panel fresh air cap as shown in Photo 1, below.
2. Apply 1/4" bead of silicone around the mating surface of the kick panel fresh air cap as shown in Figure 1, below.
3. Secure the kick panel fresh air cap using (5) OEM screws as shown in Figure 1, below.

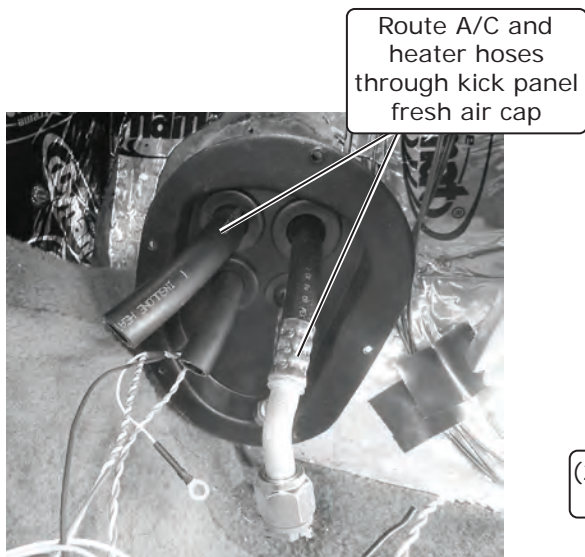

Photo 1

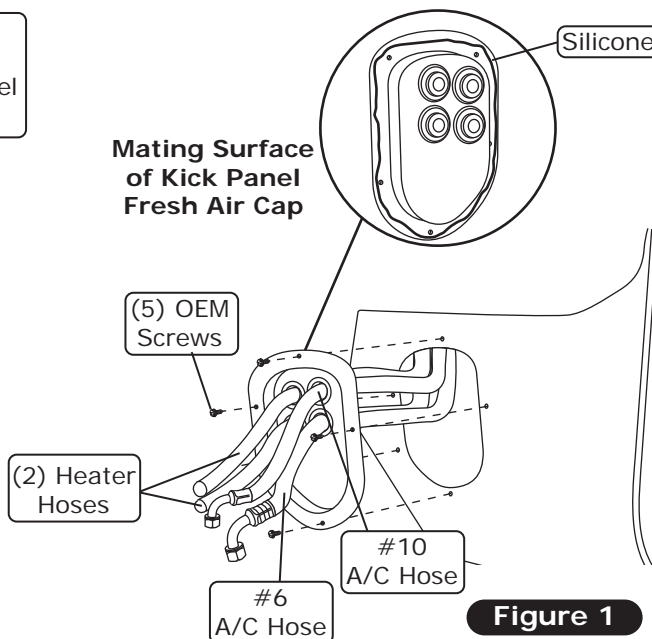

Figure 1



www.vintageair.com

Evaporator Installation

NOTE: To ensure a watertight seal between the passenger compartment and the vehicle exterior, for all bolts passing through the firewall, Vintage Air recommends coating the threads with silicone prior to installation.

1. With the evaporator module on the passenger-side floorboard, install the upper and lower heater hoses and hose clamps onto the upper and lower heater hardlines on the evaporator module (See Photos 1 and 2, below).
2. Using a properly lubricated #6 O-ring (See Lubricating O-rings, Page 21), install the 90° fitting on the #6 drier/evaporator A/C hose onto the block valve adapter on the evaporator module (See Photo 3, below).
NOTE: Provide enough A/C hose when connecting the 90° fitting to the module. Once the connection is made, pull excess hose into the engine compartment, being sure not to kink it.
3. Using a properly lubricated #10 O-ring (See Lubricating O-rings, Page 21), install the 45° fitting on the #10 compressor/evaporator A/C hose onto the #10 fitting on the block valve adapter on the evaporator module (See Photo 4, below). **NOTE: After installing the #10 compressor/evaporator A/C hose, wrap all exposed metal with the supplied press tape (See Photo 5, below).**
4. Roll the evaporator module into its mounting position and insert the (2) 1/4-20 x 1 1/2" full-threaded studs into the upper and lower OEM mounting holes on the firewall.

Install upper and lower heater hoses and hose clamps onto upper and lower heater hardlines

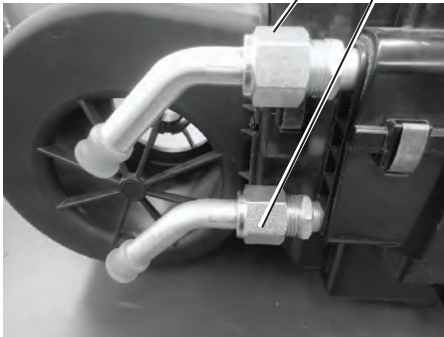

Photo 1

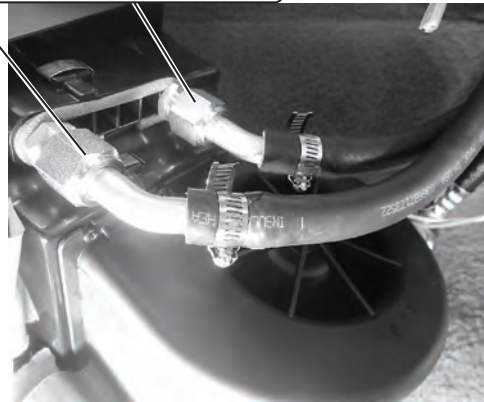

Photo 2

Install 90° fitting on #6 drier/evaporator A/C hose onto block valve adapter

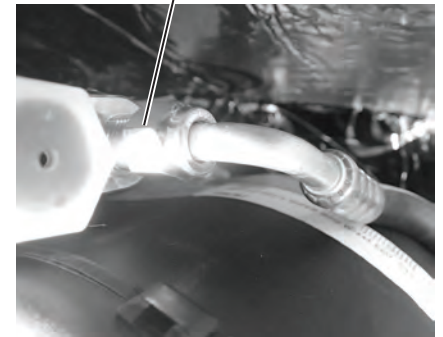

Photo 3

Install 45° fitting on #10 compressor/evaporator A/C hose onto #10 fitting block valve adapter

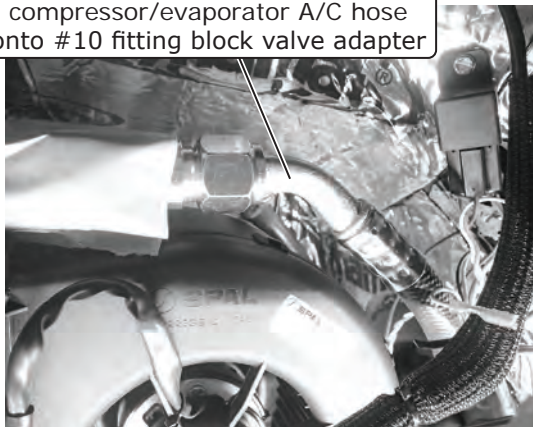
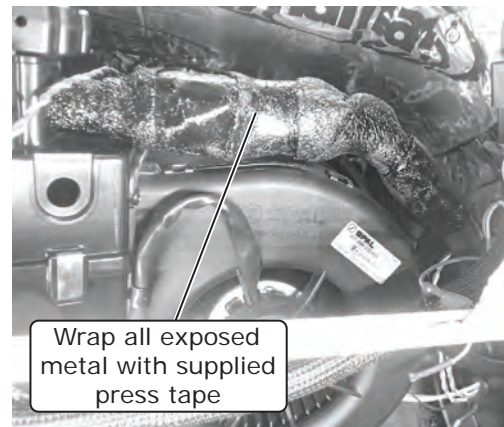

Photo 4



Wrap all exposed metal with supplied press tape

Photo 5



www.vintageair.com

Evaporator Installation (Cont.)

5. Install (2) 1/4-20 well nuts into the front mounting holes on the evaporator module (See Photo 6, below).
6. Using (2) 1/4-20 x 1" serrated flange bolts install the evaporator cowl bracket onto the evaporator module (See Photo 7, below). **NOTE: To ensure proper drainage, it is very important that the evaporator module is level, both left-right and fore-aft. Check for level on the flat portions of the case around the drain.**
7. Once the module is in position and level, use the bracket as a template to mark and drill (2) pilot holes. Secure the evaporator cowl bracket to the cowl using (2) #14 x 3/4" washer head screws (See Photos 8 and 9, below).

Install (2) 1/4-20 well nuts into front mounting holes on evaporator module

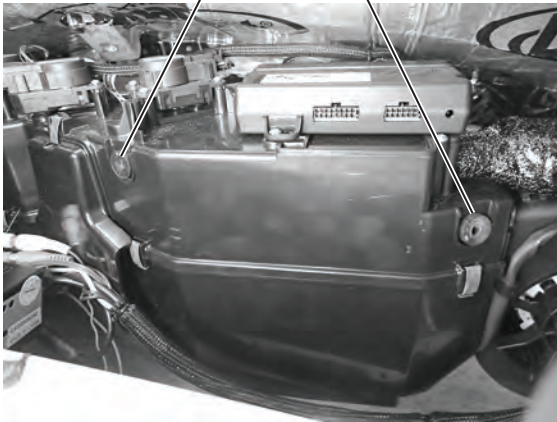
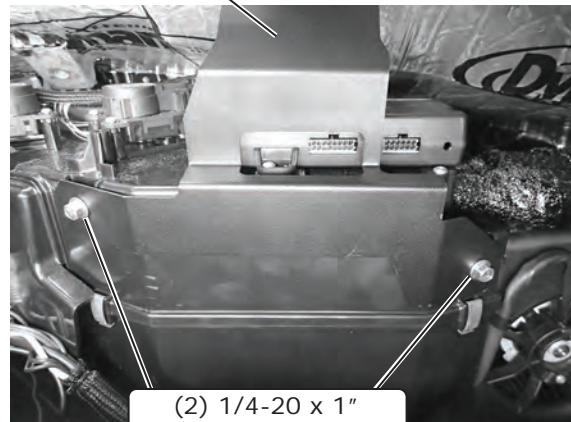

Photo 6

Evaporator Cowl Bracket 643210



(2) 1/4-20 x 1" Serrated Flange Bolts

Photo 7

Mark and drill (2) pilot holes



Photo 8

(2) #14 x 3/4" Washer Head Screws



Photo 9



www.vintageair.com

Evaporator Installation (Final)

- From the engine compartment, replace the (2) 1/4-20 x 1" serrated flange bolts with (2) 1/4-20 x 3/4" serrated flange black bolts. **NOTE: Silicone or seam sealer may be applied around the outer edge of the firewall cover (See Photo 10, below).**

Silicone or seam sealer may be applied around outer edge of firewall cover

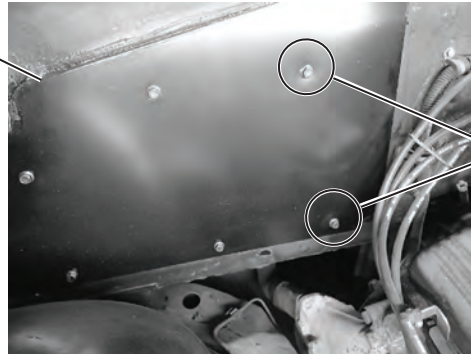

(2) 1/4-20 x 3/4" Serrated Flange Black Bolts

Photo 10

Drain Hose Installation

- Locate the evaporator drain on the bottom of the evaporator case.
- In line with the drain, lightly make a mark on the firewall. Measure 1" down, then drill a 5/8" hole through the firewall (See Photo 1, below). **NOTE: To ensure a tight fit, do not enlarge the hole to more than 5/8".**
- Locate the drain hose and cut it to 7". Install the drain elbow, then install the remaining piece of hose (See Photos 2 and 3, below).
- From the engine compartment, route the 7" piece of drain hose through the firewall and connect it to the evaporator drain outlet (See Photos 4 and 5, below).
- Route drain away from the exhaust.

In line with drain, lightly make a mark on firewall.

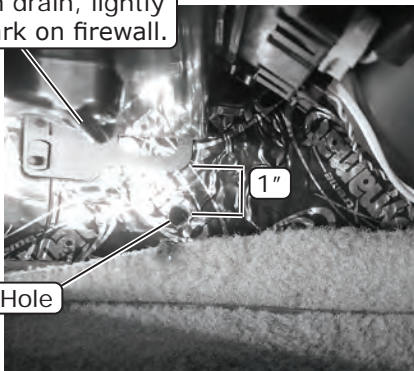

Drill 5/8" Hole

Photo 1

Cut drain hose to 7"

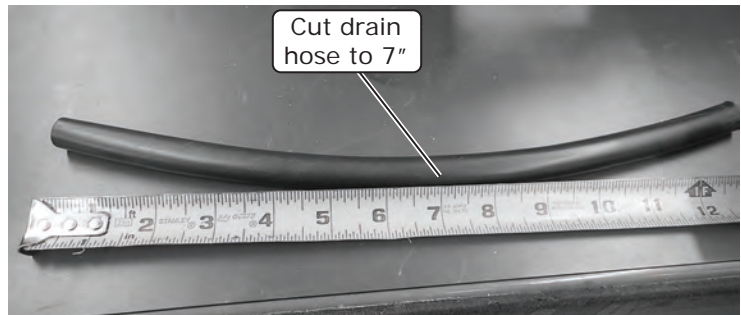

Photo 2

Install drain elbow then install remaining piece of hose

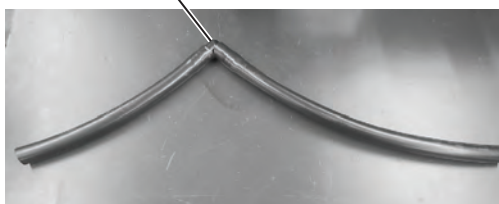

Photo 3

From engine compartment, route 7" piece of drain hose through firewall and connect it to evaporator drain outlet

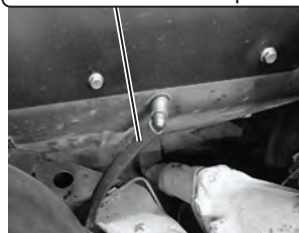

Photo 4

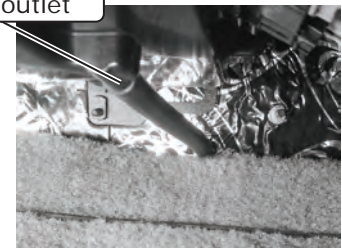

Photo 5



www.vintageair.com

Fresh Air Cap Installation

NOTE: Use soapy water on hoses to help ease installation.

1. With wiring and hoses routed into the engine compartment through the fresh air cap grommets, slide the fresh air cap to the firewall and secure it using (2) #14 x 3/4" washer head screws in the OEM screw locations (See Photo 1, below). Apply silicone to the mating area.

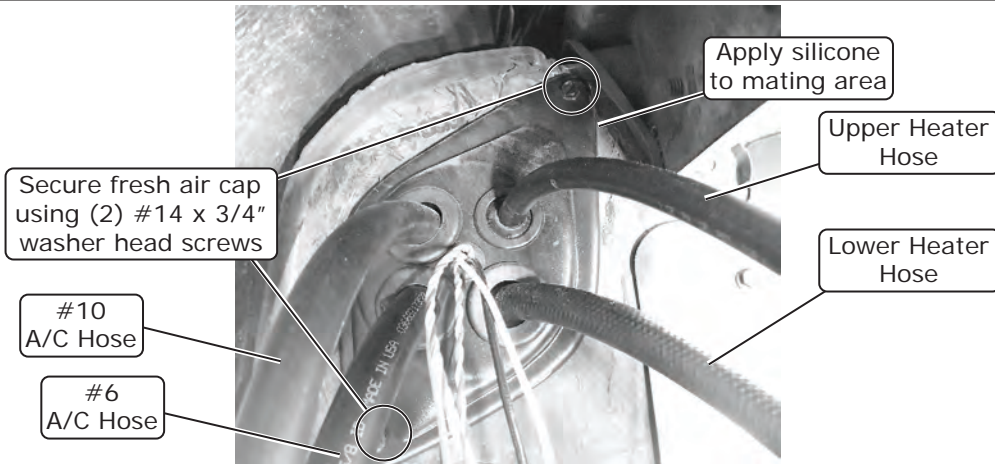

Photo 1

Heater Hose & Heater Control Valve Installation

NOTE: Vintage Air systems use 5/8" heater connections. On engines equipped with 3/4" hose nipples, these will need to be removed and replaced with 5/8" nipples (not supplied). For water pumps with a cast-in 3/4" heater outlet, a 3/4" x 5/8" reducer fitting (not supplied) or molded hose will need to be installed in the heater hose.

1. Route the lower heater hose to the water pump fitting, then secure it using the supplied hose clamp (See Photo 1, below).
2. Cut the upper heater hose 4 to 5 inches from the fresh air cap and install the heater control valve into the upper heater hose. Secure the heater control valve using the supplied hose clamp (See Photo 2, below).

NOTE: Ensure proper flow direction through the heater control valve. The flow direction follows the molded arrow on the valve (See Figure 1, below).

Route lower heater hose to water pump fitting, then secure it using supplied hose clamp

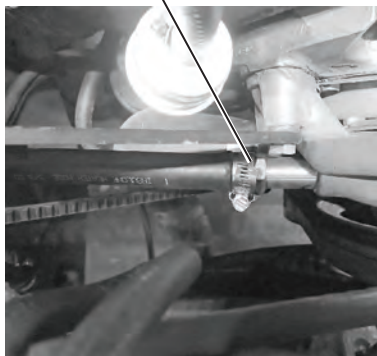

Photo 1

Install heater control valve into upper heater hose

Secure using supplied hose clamp

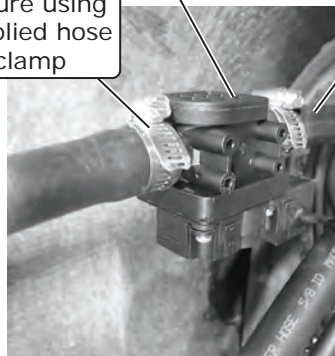

Photo 2

Cut heater hose 4" to 5" from fresh air cap

From Heater Control Valve to Heater Core

Heater Hose

NOTE: Flow Direction Follows Molded Arrow on Valve

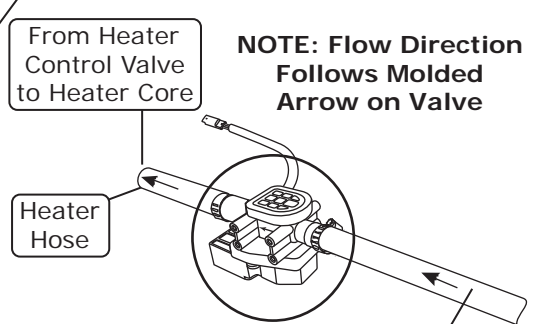

Figure 1

From Intake Manifold



www.vintageair.com

Heater Hose & Heater Control Valve Installation (Cont.)

3. Install another length of heater hose from the heater control valve to the intake and secure it using the supplied hose clamp (See Photo 3, below).
4. Plug the heater control valve connector into the heater control valve connector wiring harness (See Photo 4, below).

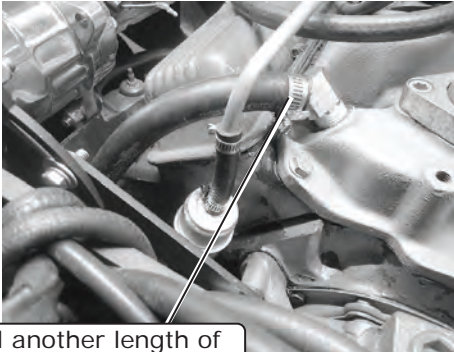

Install another length of heater hose from heater control valve to intake and secure using hose clamp

Photo 3

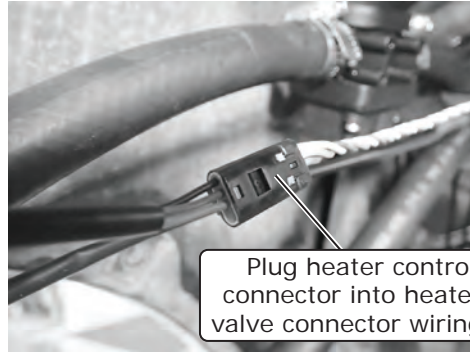

Plug heater control valve connector into heater control valve connector wiring harness

Photo 4

A/C Hose Installation

Standard Hose Kit:

1. Locate the #8 compressor A/C hose. Lubricate (2) #8 O-rings (See Lubricating O-rings, Page 21), and connect the 90° female fitting with service port to the #8 discharge port on the compressor (See Photo 1, below). Then, route the 90° fitting to the #8 condenser fitting (See Photo 2, below). Tighten each fitting connection.
2. With a properly lubricated #10 O-ring (See Lubricating O-rings, Page 21), connect the #10 135° female fitting with service port to the #10 suction port on the compressor (See Photo 1, below).
3. With a properly lubricated #6 O-ring (See Lubricating O-rings, Page 21), connect the #6 45° fitting to the drier (See Photo 3, below).

Modified Hose Kit:

1. Refer to separate instructions included with modified hose kit.

Connect #8 A/C hose 90° female fitting with service port to #8 discharge port on compressor

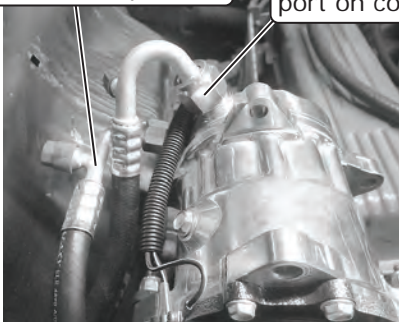

Photo 1

Connect #10 A/C hose 135° female fitting with service port to #10 suction port on compressor

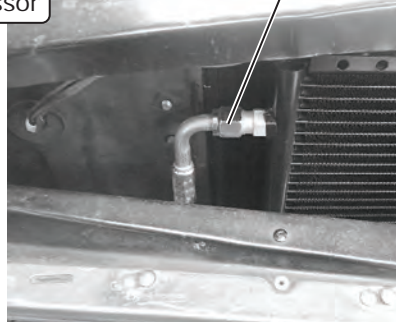

Photo 2

Route #8 A/C hose 90° fitting to #8 condenser fitting



Photo 3

Connect #6 A/C hose 45° fitting to drier



www.vintageair.com

A/C and Heater Hose Routing

NOTE: Vintage Air Systems use 5/8" heater connections. On engines equipped with 3/4" hose nipples, these will need to be removed and replaced with 5/8" nipples (not supplied). For water pumps with a cast-in 3/4" heater outlet, a 3/4" x 5/8" reducer fitting (not supplied) will need to be installed in the heater hose.

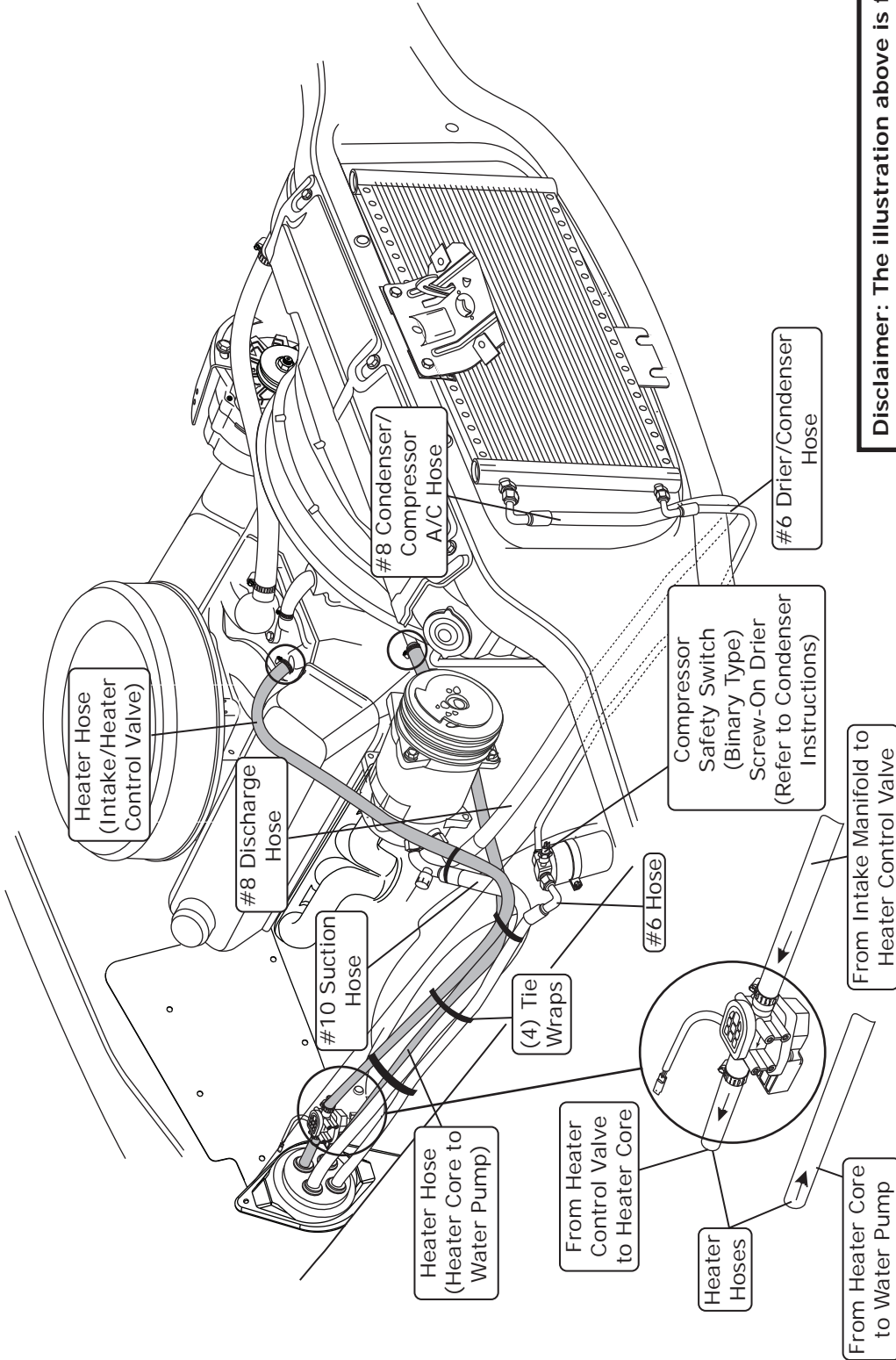

Disclaimer: The illustration above is for reference only. Hose routing and fittings may differ depending on install and/or engine configuration.

NOTE: Flow Direction Follows Molded Arrow on Valve.



www.vintageair.com

Dash Support Bracket Installation

1. Loosely install the new dash support bracket using a 5/16-18 x 3/4" hex bolt in the top mounting location (See Photos 1 and 2, below) and a 1/4-20 x 3/4" hex bolt with a .625" O.D. x .281" I.D. washer in the lower mounting location (See Photo 3, below). Once the bracket is in place tighten hardware.

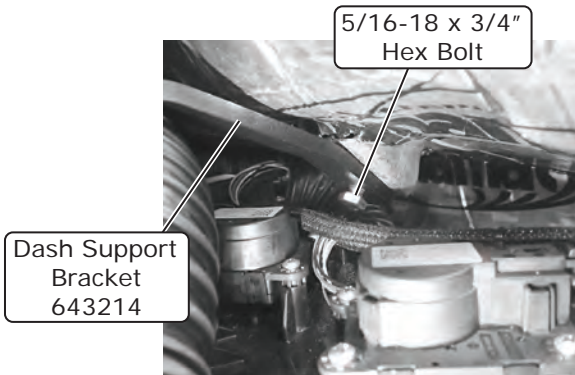

Photo 1

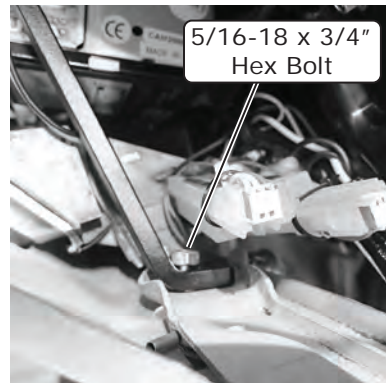
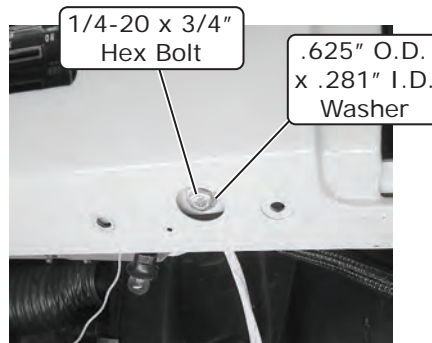

Photo 2



Bottom of Dash Shown

Photo 3

Wiring Final

1. Select a suitable ground location for the white ground wire eyelet from the heater control valve harness and secure it using a #10 x 1/2" sheet metal screw.
2. Route the violet power wire to a switched 12v power source on the fuse panel (See Photo 1, below).
NOTE: This requires a male fuse extension (not supplied).
3. Connect the tan wire to the factory dash lights to enable control panel backlighting (if applicable).
4. Connect the main harness to the ECU (See Photo 2, below).
5. Select a suitable mounting location for the main relay.

Attach violet wire to switched power source



Photo 1

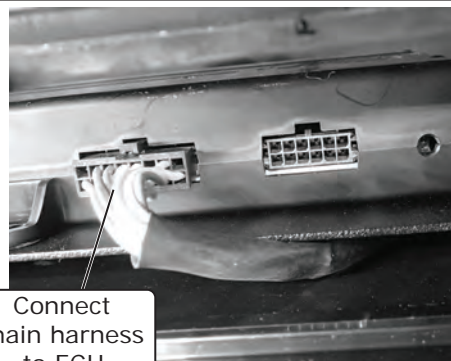

Connect main harness to ECU

Photo 2



www.vintageair.com

Engine Compartment Wiring

1. Route the power and ground wires toward the battery.
 2. Install the supplied heat shrink over the 12 AWG orange fuse holder assembly wire, and crimp it to the 12 AWG orange wire from the main wiring harness (See Photo 1, below and Quality Crimp Guidelines, Page 36).
 3. Install the supplied heat shrink over the 16 AWG black fuse holder assembly wire, and crimp it to the 16 AWG red wire from the main wiring harness (See Photo 2, below and Quality Crimp Guidelines, Page 36).
 4. Install fuses into the holders (See Photo 3, below).
 5. Install the supplied heat shrink over the white ground wires, then crimp on the supplied eyelets (See Photos 4 and 5, below and Quality Crimp Guidelines, Page 36)
 6. Connect the ground wiring eyelets to the negative battery terminal connector (See Photo 6, below).
 7. Connect the positive wiring eyelets to the positive battery terminal connector (See Photo 7, below).
- NOTE: Do not connect power until installation is completed.**

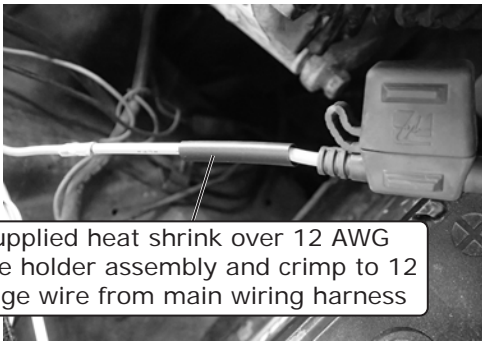

Install supplied heat shrink over 12 AWG orange fuse holder assembly and crimp to 12 AWG orange wire from main wiring harness

Photo 1

Install supplied heat shrink over 16 AWG black fuse holder assembly wire and crimp to 16 AWG red wire from main wiring harness

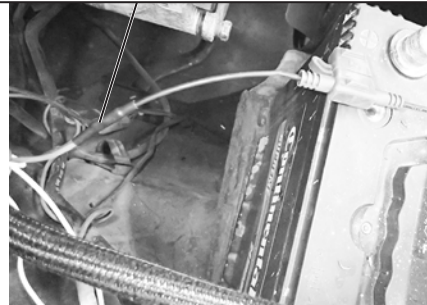

Photo 2

Install fuses into holders



Photo 3

Install supplied heat shrink over white ground wires and crimp on supplied eyelets

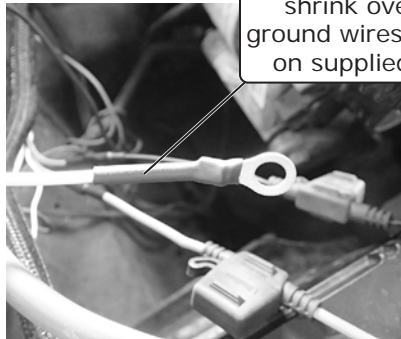

Photo 4

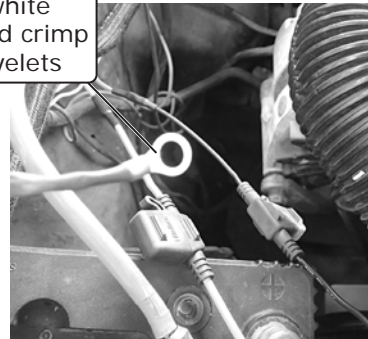

Photo 5

Connect ground wiring eyelets to negative battery terminal connector

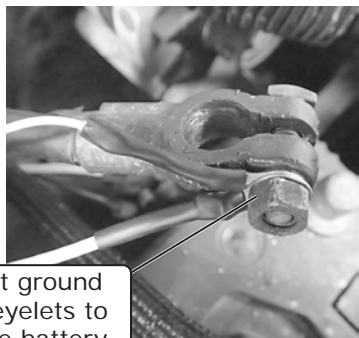

Photo 6

NOTE: Do not connect power until installation is completed.

Connect positive wiring eyelets to positive battery terminal connector

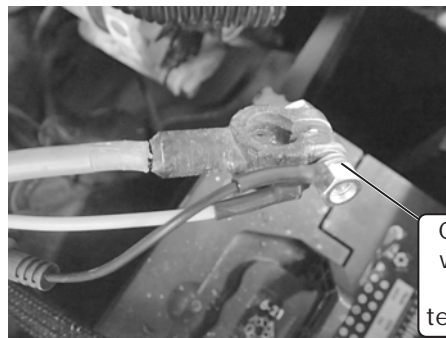

Photo 7



www.vintageair.com

Final Steps: Installation Check

Installation Check	
ITEM TO CHECK	Procedure
<input type="checkbox"/>	<p>ECU</p> <p>If no blinking is observed after 1 minute of turning the ignition on, go to the next check.</p> <p>If repetitive blinking is observed, go to the Advanced Diagnostics Section to diagnose.</p>
<input type="checkbox"/>	<p>Blower speed control</p> <p>Set the blower speed control to OFF, <u>confirm that the blower is off</u>.</p> <p>Position the blower speed control to LOW then MEDIUM and then HIGH. <u>At each setting confirm that the blower speed increases</u>, do this by feeling for the amount of air coming from the unit and hearing the blower speed increase.</p>
<input type="checkbox"/>	<p>Mode control</p> <p>Set the MODE control to the DASH position. <u>Confirm that air is being blown at the dash vents</u>.</p> <p>Set the MODE control to the FLOOR position. <u>Confirm that air is being blown at the floor vents</u>.</p> <p>Set the MODE control to the DEFROST position. <u>Confirm that all air is being blown from the defrost vents</u></p> <p>If heater lines are installed:</p> <p>Set the MODE control to the DASH position. Set the TEMP control to the MAX HEAT position. <u>Confirm that HOT air is coming from the dash vents</u>.</p>
<input type="checkbox"/>	<p>Temperature control</p> <p>If system is charged:</p> <p>Set the TEMP control to the MAX COOL position. <u>Confirm that COLD air is coming from the dash vents</u>.</p> <p>Also <u>confirm that the compressor "clicks" on</u> when adjusting the TEMP control from the MAX HEAT position to the MAX COOL position.</p>
<input type="checkbox"/>	<p>AC Indicator (If applicable)</p> <p>While the MODE control is set to the DASH position, and the TEMP control is set to the MAX COOL/MIN HEAT position, <u>confirm that the blue AC Indicator light is on</u>.</p>
<input type="checkbox"/>	<p>Backlight (If applicable)</p> <p>If your control panel has backlight capabilities and has been wired, turn the dash lamp on and <u>confirm that the AC panel's legend is lit</u>.</p>
<input type="checkbox"/>	<p>Fittings</p> <p>Verify AC and Heater fittings are all tight.</p>



www.vintageair.com

Final Steps: Completing the Install

1. Install duct hoses as shown in Figure 1, Page 35.
2. Install the control panel assembly. Refer to the control panel instructions.
3. Insert new glove box assembly open side up, right side first (See Photo 1, below). Rotate the glove box assembly forward into position lining up the (4) mounting holes (See Photos 2 and 3, below).
4. Using (4) #8 x 1/2" pan head screws, secure the glove box to the dash (See Photo 4, below).
5. Reinstall glove box door using OEM hardware (See Photos 5 and 6, below).
6. Reinstall all previously removed items (battery tray, battery, and inner fender).
7. Fill radiator with at least a 50/50 mixture of approved antifreeze and distilled water. It is the owner's responsibility to keep the freeze protection at the proper level for the climate in which the vehicle is operated. Failure to follow antifreeze recommendations will cause heater core to corrode prematurely and possibly burst in A/C mode and/or freezing weather, voiding your warranty.
8. Double check all fittings, brackets and belts for tightness.
9. Vintage Air recommends that all A/C systems be serviced by a licensed automotive A/C technician.
10. Evacuate the system for a minimum of 45 minutes prior to charging, and perform a leak check prior to servicing.
11. Charge the system to the capacities stated on Page 4 of this instruction manual.
12. See Operation of Controls procedures on Page 39.

Insert glove box assembly open side up, right side first



Photo 1

Glove Box Assembly 625666

Rotate glove box forward into position lining up (4) mounting holes

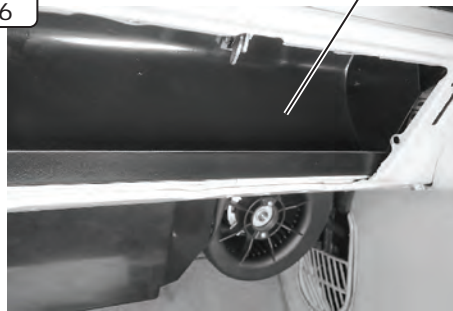

Photo 2

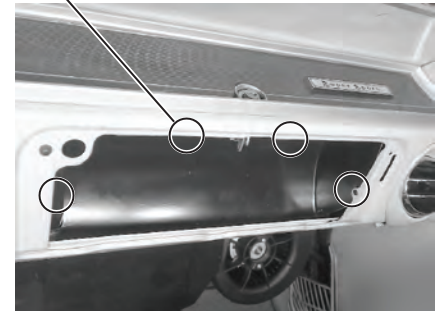

Photo 3

Using (4) #8 x 1/2" pan head screws secure glove box to dash

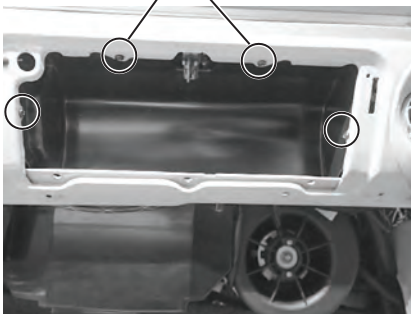

Photo 4

Reinstall glove box door using OEM hardware

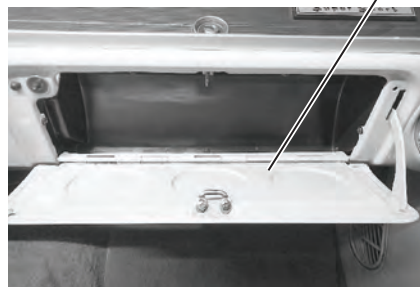

Photo 5

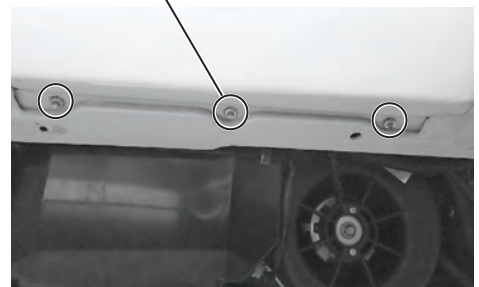

Photo 6



www.vintageair.com

ECU, Control Panel & Duct Hose Routing

NOTE: For the system to function optimally, the duct hoses must be routed as directly as possible, taking care to avoid kinks, sharp bends and unnecessary length. Vintage Air supplies duct hoses in continuous lengths that will need to be cut to size depending on application. Before cutting, familiarize yourself with the installation instructions and verify the routing will work with your application. For custom hose routing, additional hose may be needed and can be purchased from Vintage Air.

1. Stretch the duct hose until there is no slack, measure, mark and cut hose to size (See Photo 1, below).
2. Refer to Figure 1, below, for duct hose routing.
3. Attach 2 ½" duct hose to each hose adapter and connect to the evaporator as shown in Figure 1, below.
4. Recommended duct hose routing shown in Photos 2 and 3, below.

Stretch, measure, mark and cut hose to size



Photo 1

Disclaimer: Before cutting duct hose to length, verify the routing will work for your application.

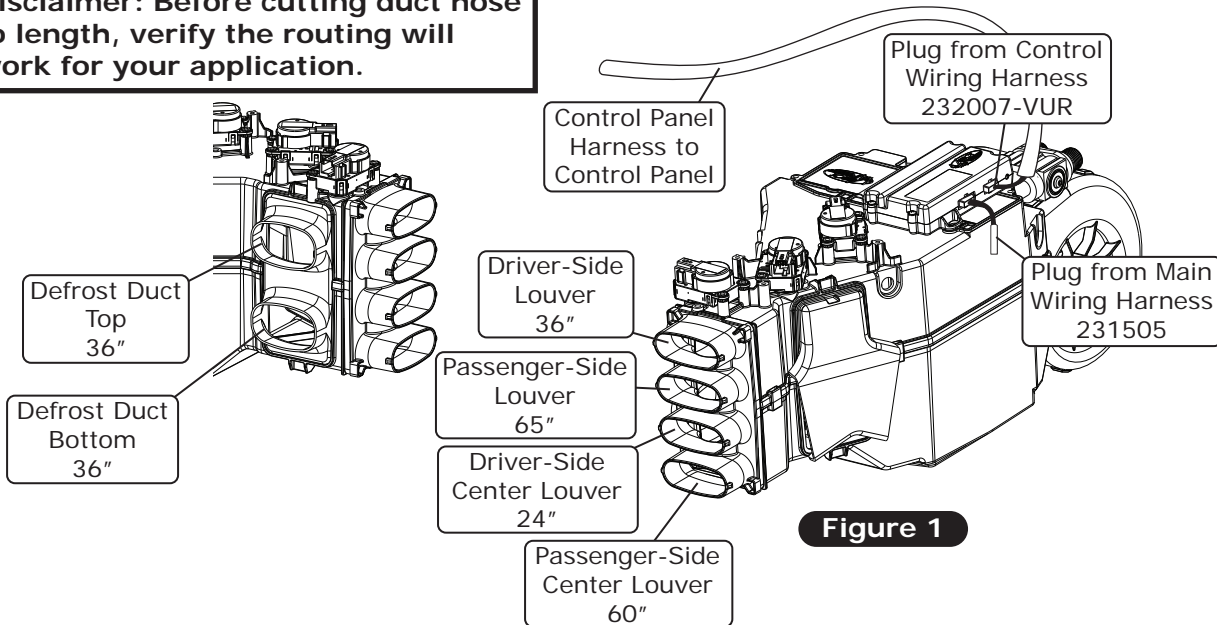
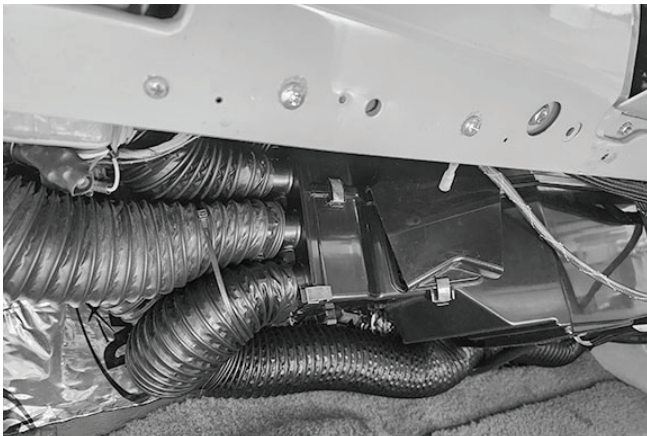
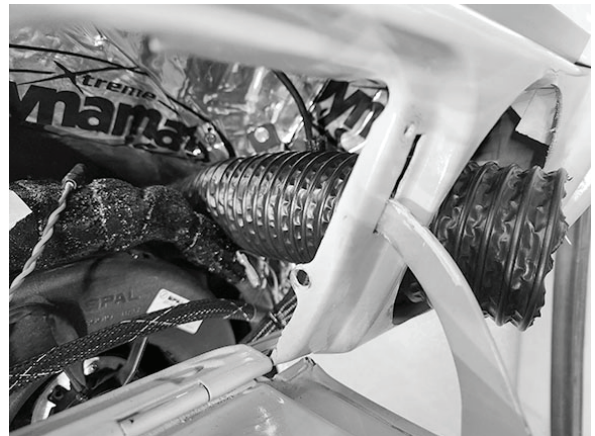

Figure 1



Recommended Duct Hose Routing

Photo 2



Recommended Duct Hose Routing

Photo 3



www.vintageair.com

Quality Crimp Guideline

Acceptable strip length
(Some copper visible)

Crimped area is centered
on each side of splice

Bad strip length
(Too much copper visible)
Visible copper should be
just enough to ensure
clearance between splice
area and wire insulation

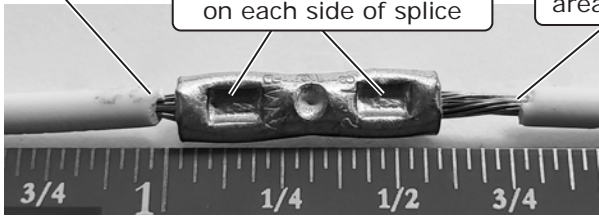

Photo 1

A good crimp requires
seam of butt splice to be
opposite of crimp die tooth

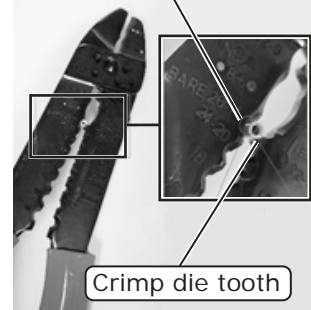

Photo 2

Good Ring Terminal Crimp Bad Ring Terminal Crimp



Crimped
area is
opposite
of seam

Photo 3

Crimp
area is
centered
on barrel

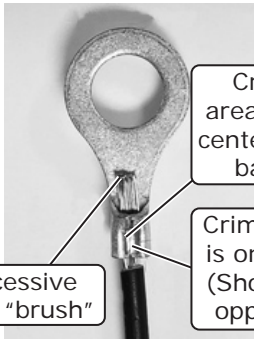

Crimp
area is not
centered on
barrel

Excessive
wire "brush"

Crimp area
is on seam
(Should be
opposite)

Photo 4



Photo 5

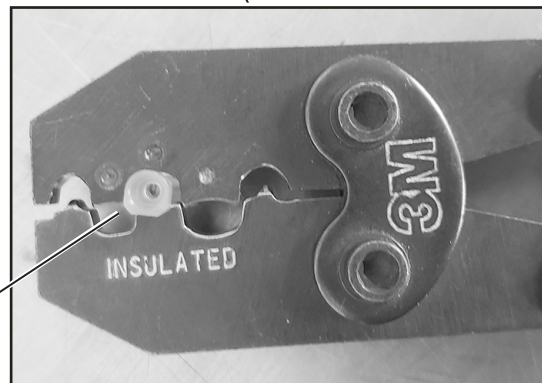

Photo 5a

Use a ratcheting crimp tool
for insulated barrel terminals
when crimping the provided
female insulated terminal.
Ensure terminal is inserted in
appropriate position before
crimping.



www.vintageair.com

Gen 5 Wiring Diagram

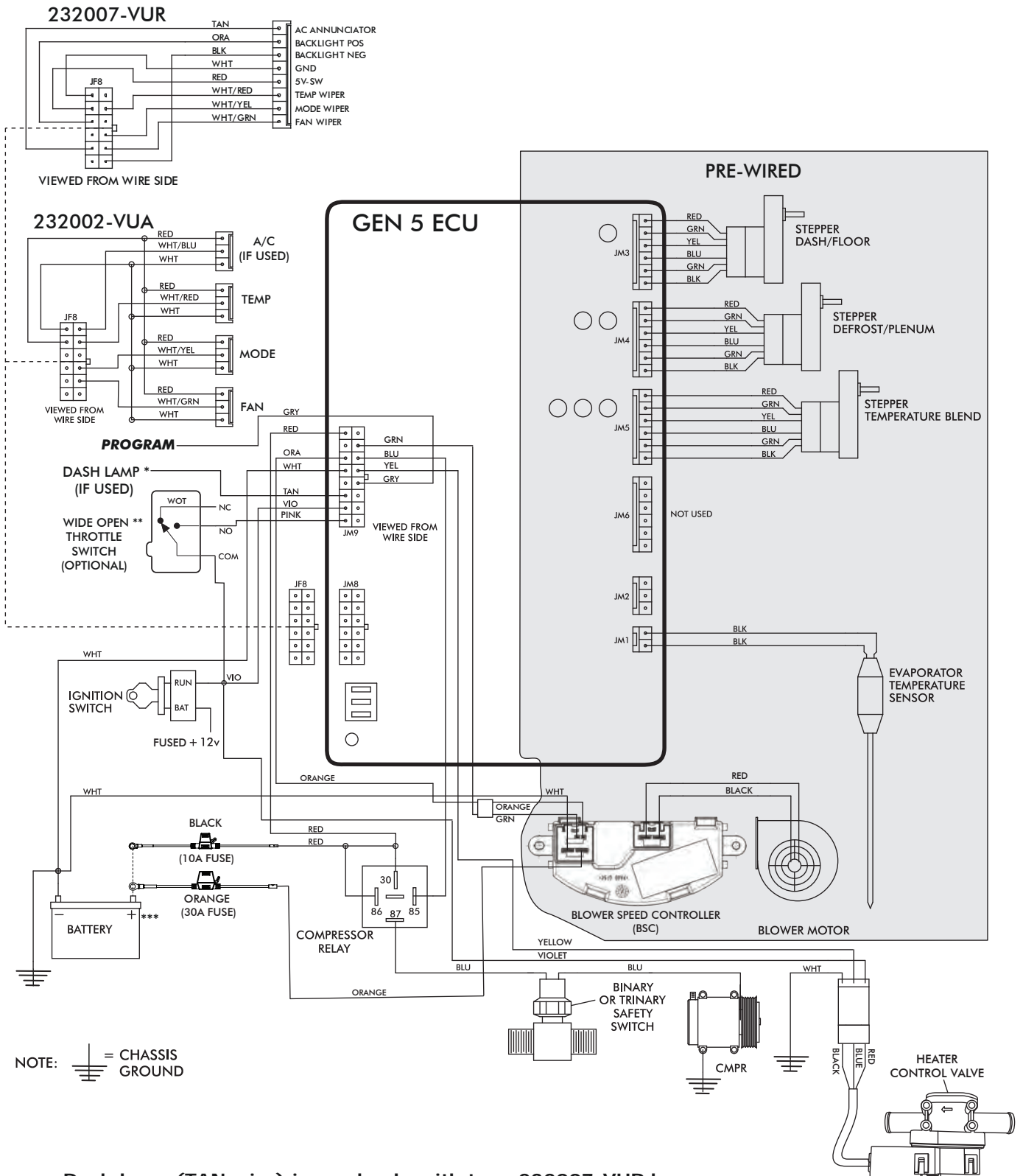

NOTE: = CHASSIS GROUND

- * Dash lamp (TAN wire) is used only with type 232007-VUR harness.
- ** Wide open throttle switch contacts close only at full throttle, which disables A/C compressor.
- *** Install fuse assemblies at or as near to the battery as possible.



www.vintageair.com

Gen 5 Wiring Instructions

WIRING HARNESS (231505) ↓

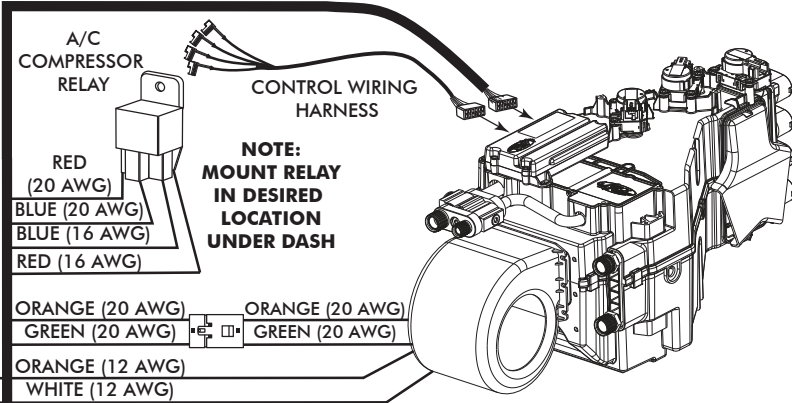

NOTE:
MOUNT RELAY
IN DESIRED
LOCATION
UNDER DASH

Ignition Switch:

Using provided butt splice (PN 226004), connect the 20 AWG violet wire to a 5A fused and switched 12V source such as Key On.

Wide Open Throttle Switch (Optional):

If a wide open throttle switch is required, connect the 20 AWG pink wire to a normally open switch that, when closed, connects a fused and switched 12V source to the pink wire. See Gen 5 wiring diagram for an example.

Dash Light (Optional):

If using a Vintage Air control panel with back light, connect the 20 AWG tan wire to the vehicle's dash back light 0-12V using provided butt splice (PN 226004).

WIRING HARNESS (232020) →

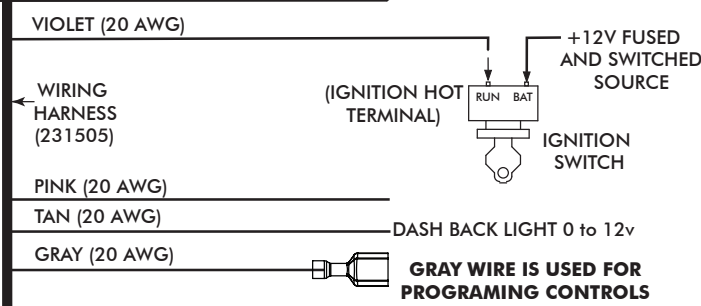

GRAY WIRE IS USED FOR PROGRAMING CONTROLS IF APPLICABLE

FIREWALL

FIREWALL

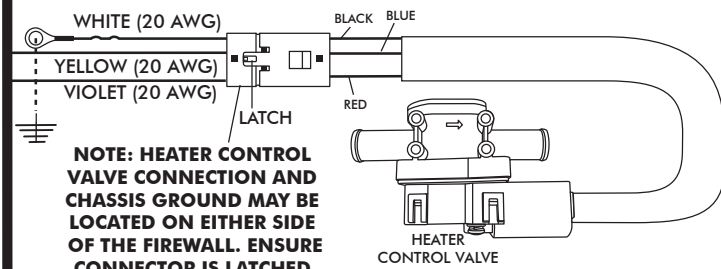

NOTE: HEATER CONTROL VALVE CONNECTION AND CHASSIS GROUND MAY BE LOCATED ON EITHER SIDE OF THE FIREWALL. ENSURE CONNECTOR IS LATCHED FIRMLY.

Heater Control Valve:

Connect the Violet/Yellow/White twisted branch with 3 position connector into the heater control valve connector. Ensure that the mating latch is fully seated.

Binary/Trinary & Compressor:

Binary Switch: Terminate provided insulated female terminal (PN 23172-VUW) to the blue 16 AWG wire. Connect as shown.
Trinary Switch: Connect according to trinary switch wiring diagram.

WIRING HARNESS (232020) →

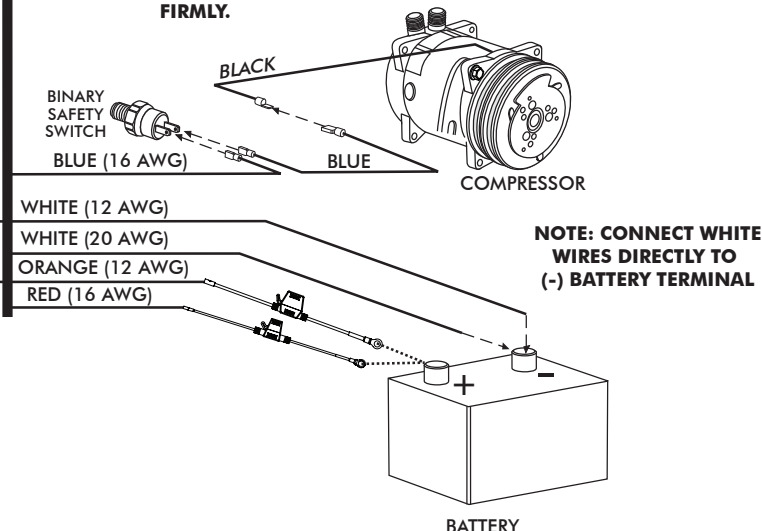

NOTE: CONNECT WHITE WIRES DIRECTLY TO (-) BATTERY TERMINAL

Battery Connections:

ECU Ground: Terminate provided ring terminal (PN 226110) to 20 AWG white wire from the 231505 wire assembly and install at battery.
ECU PWR: Terminate provided fuse assembly with black leads (PN 233012) to the 20 AWG red wire from the 231505 wire assembly. Install provided 10A Red Mini Fuse (PN 226118). Install at battery.
Blower Speed Controller (BSC) Ground: Terminate provided ring terminal (PN 226111) to 12 AWG white wire from the 232020 wire assembly and install at battery.
Blower Speed Controller (BSC) PWR: Terminate provided fuse assembly with orange leads (PN 233008) to the 12 AWG orange wire from the 232020 wire assembly. Install provided 30A Green ATO/ATC Fuse (PN 226125). Install at battery.



www.vintageair.com

Operation of Controls

On Gen IV systems with three lever/knob controls, the temperature control toggles between heat and A/C operations. To activate A/C, move the temperature lever/knob all the way to cold and then back it off to the desired vent temperature. For heat operation, move the temperature lever/knob all the way to hot and then adjust to the desired vent temperature. The blower will momentarily change speed, each time you toggle between operations, to indicate the change. **NOTE: For proper control panel function, refer to control panel instructions for calibration procedure.**

Blower Speed

This lever/knob controls blower speed, from OFF to HI.

Mode Control

This lever/knob controls the mode positions, from DASH to FLOOR to DEFROST, with a blend in between.

Temperature Control

This lever/knob controls the temperature, from HOT to COLD.

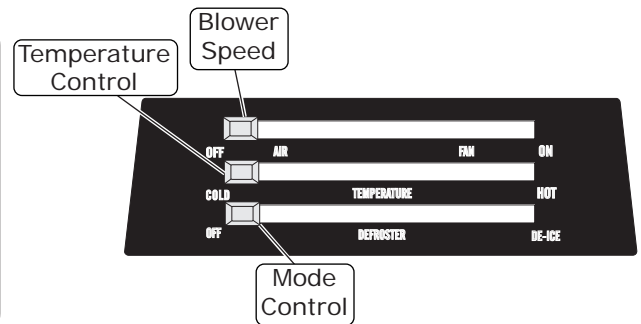

A/C Operation

Blower Speed

Adjust to desired speed.

Mode Control

Adjust to desired mode position (DASH position recommended).

Temperature Control

For A/C operation, adjust to coldest position to engage compressor (Adjust between HOT and COLD to reach desired temperature).

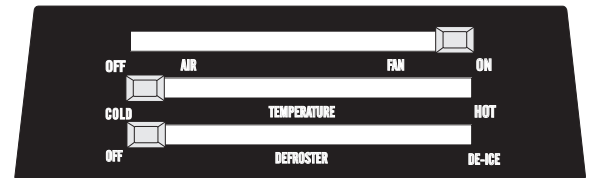

Heat Operation

Blower Speed

Adjust to desired speed.

Mode Control

Adjust to desired mode position (FLOOR position recommended).

Temperature Control

For maximum heating, adjust to hottest position (Adjust between HOT and COLD to reach desired temperature).

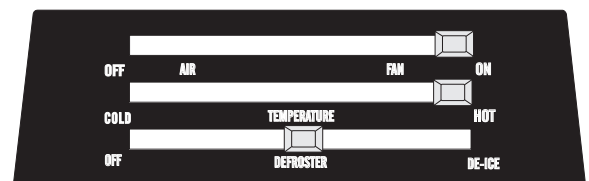

Defrost/De-fog Operation

Blower Speed

Adjust to desired speed.

Temperature Control

Adjust to desired temperature.

Mode Control

Adjust to DEFROST position for maximum defrost, or between FLOOR and DEFROST positions for a bi-level blend (Compressor is automatically engaged).

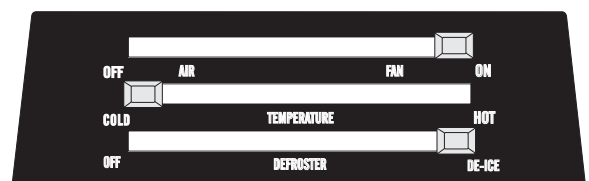



www.vintageair.com

Troubleshooting Guide

This printed troubleshooting guide is our basic guide that covers common installation problems. To see our advanced diagnostics and troubleshooting guide, please refer to the following page for instructions on how to download the complete guide.

WARNING: While troubleshooting the system, never probe connector terminals from the front mating side, only back probe.

WARNING: While troubleshooting the system, never use automotive check lights.

Symptom	Condition	Checks	Actions	Notes
1. Blower stays on high speed with ignition on.	No other functions work.	Check for damaged pins or wires in the control panel wire assembly and mating header at ECU.	If found damaged, replace wire assembly or ECU.	If fuse continues to blow, there is a serious problem in the wiring. Check all wiring and ensure the wire is not damaged and shorting out along its route.
	All other functions work.	Check for a bad ECU GND. Check for damaged pins or wires in the control panel wire assembly and mating header at ECU. Check if Blower power fuse is blown. Check for a bad ECU GND.	If found damaged, replace wire assembly or ECU. Replace fuse. Repair connection.	
2. Compressor will not turn on (All other functions work).	System is not charged.	System must be charged for compressor to engage.	Charge system.	Danger: Never bypass safety switch with engine running. Serious injury can result.
	System is charged.	Check for faulty A/C potentiometer or associated wiring (not applicable to 3-pot controls). Check for disconnected or faulty thermistor.	Check continuity to ground on white control head wire. Check for 5V on red control head wire. Check 2-pin connector at ECU housing.	To check for proper pot function, check voltage at white/red wire. Voltage should be between 0V and 5V, and will vary with pot lever position. Disconnected or faulty thermistor will cause compressor to be disabled.
	Compressor will not turn off (All other functions work).	Check for faulty A/C potentiometer or associated wiring.	Repair or replace pot/control wiring.	Red wire at A/C pot should have approximately 5V with ignition on. White wire will have continuity to chassis ground. White/Red wire should vary between 0V and 5V when lever is moved up or down.
3. Compressor will not turn off (All other functions work).	System is charged.	Check for faulty A/C relay.	Replace relay.	



www.vintageair.com

Troubleshooting Guide (Cont.)

Symptom	Condition	Checks	Actions	Notes
4. System will not turn on, or runs intermittently.	Works when engine is not running; shuts off when engine is started	Noise interference from either ignition or alternator.	Install capacitors on ignition coil and alternator. Ensure good ground at all points. Relocate coil and associated wiring away from ECU and ECU wiring. Check for burned or loose plug wires.	Ignition noise (radiated or conducted) will cause the system to shut down due to high voltage spikes. If this is suspected, check with a quality oscilloscope. Spikes greater than 16V will shut down the ECU. Install a radio capacitor at the positive post of the ignition coil (see radio capacitor installation bulletin). A faulty alternator or worn out battery can also result in this condition.
	Will not turn on under any conditions.	Verify connections on power lead, ignition lead, and both white ground wires. Verify battery voltage is greater than 10 volts and less than 16 while engine is running.	Check for power at ECU, and confirm ignition is being applied to ECU properly. Verify proper meter function by checking the condition of a known good battery.	
5. Loss of mode door function.	No mode change at all.	Check for damaged mode switch or potentiometer and associated wiring.		
	Blower turns on and off rapidly.	Battery voltage is at least 12V. Battery voltage is less than 12V.	Ensure all system grounds and power connections are clean and tight. Charge battery.	System shuts off blower at 10V. Poor connections or weak battery can cause shutdown at up to 11V.
7. Erratic functions of blower, mode, temp, etc.		Check for damaged switch or pot and associated wiring.	Repair or replace.	

Advanced Diagnostics and Troubleshooting Guide

If after referencing the Troubleshooting Guide, the issue is not resolved, move to The Advanced Diagnostics and Troubleshooting Guide that covers the following:

- **ECU Diagnostics Codes**
 1. ECU Blink Sequence
 2. Firmware Version Number
 3. ECU Model Number
 4. ECU Start-Up Blink Sequence
 5. Diagnostic Codes
- **Complete Advanced Troubleshooting Guidelines**

Access the latest version of the Advanced Diagnostics and Troubleshooting Guide by scanning the following QR code on your mobile device:



You can also access the guide by typing the following address into your web browser:

https://www.vintageair.com/instructions_pdf/905000.pdf

Cut Along
Dotted Line

1966 Chevelle Kick Panel Modification Template

Cut Along
Dotted Line

Cut Out This Area

NOTE: Due to printing variances, measure the line below before using this template. If template is scaled properly, the line should measure 6 inches.

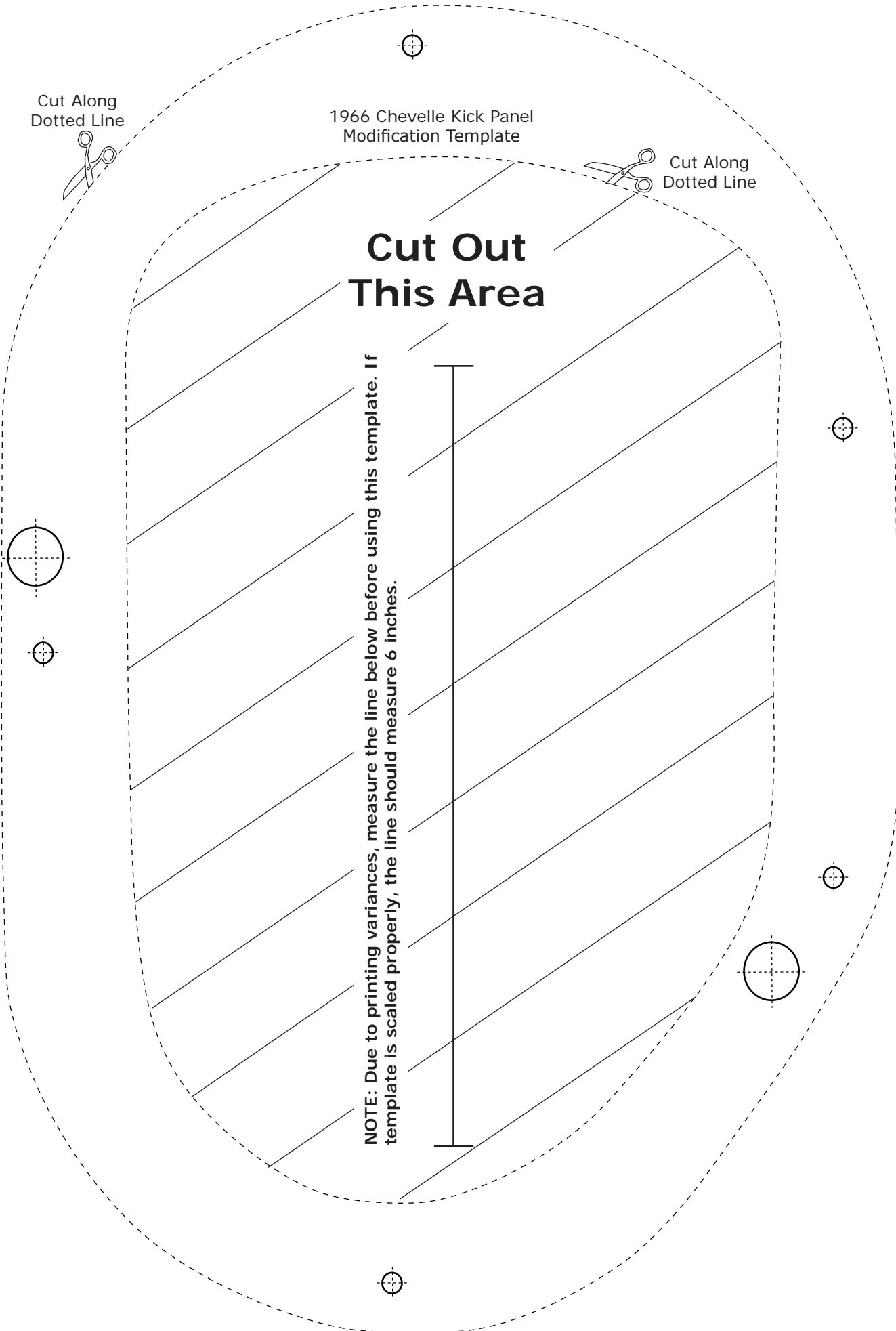

1967 Chevelle Kick Panel
Modification Template

Cut Along
Dotted Line



Cut Along
Dotted Line

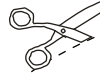

**Cut Out
This Area**

**NOTE: Due to printing variances, measure the line below before using this template. If
template is scaled properly, the line should measure 6 inches.**

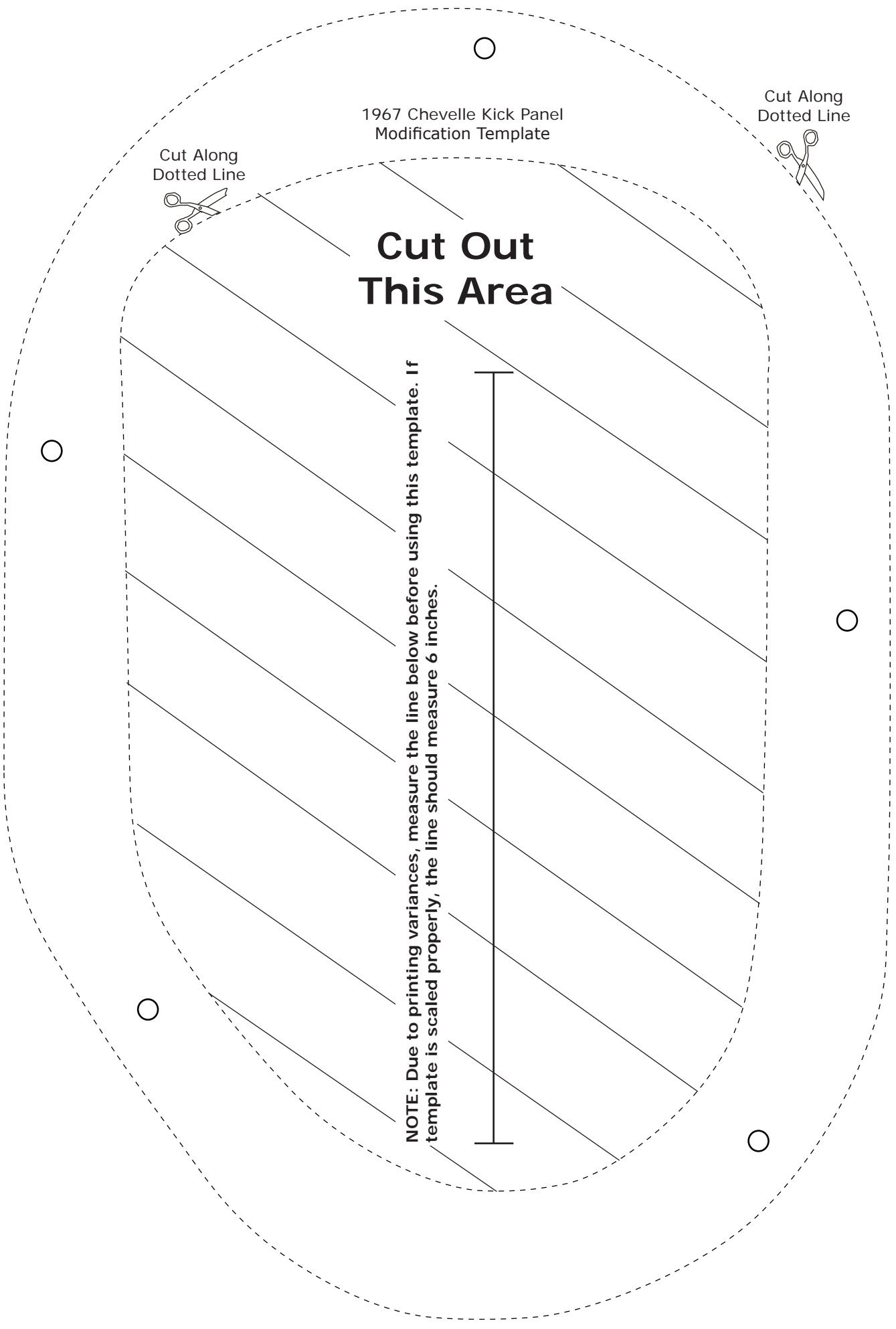



www.vintageair.com

Packing List: Evaporator Kit (561273)

No.	Qty.	Part No.	Description
1.	1	765225	Gen 5 Super Magnum Module with 444 ECU
2.	1	781273	Accessory Kitt

Checked By: _____
Packed By: _____
Date: _____

1



**Gen 5 Super Magnum
Module with 444 ECU
765225**

2

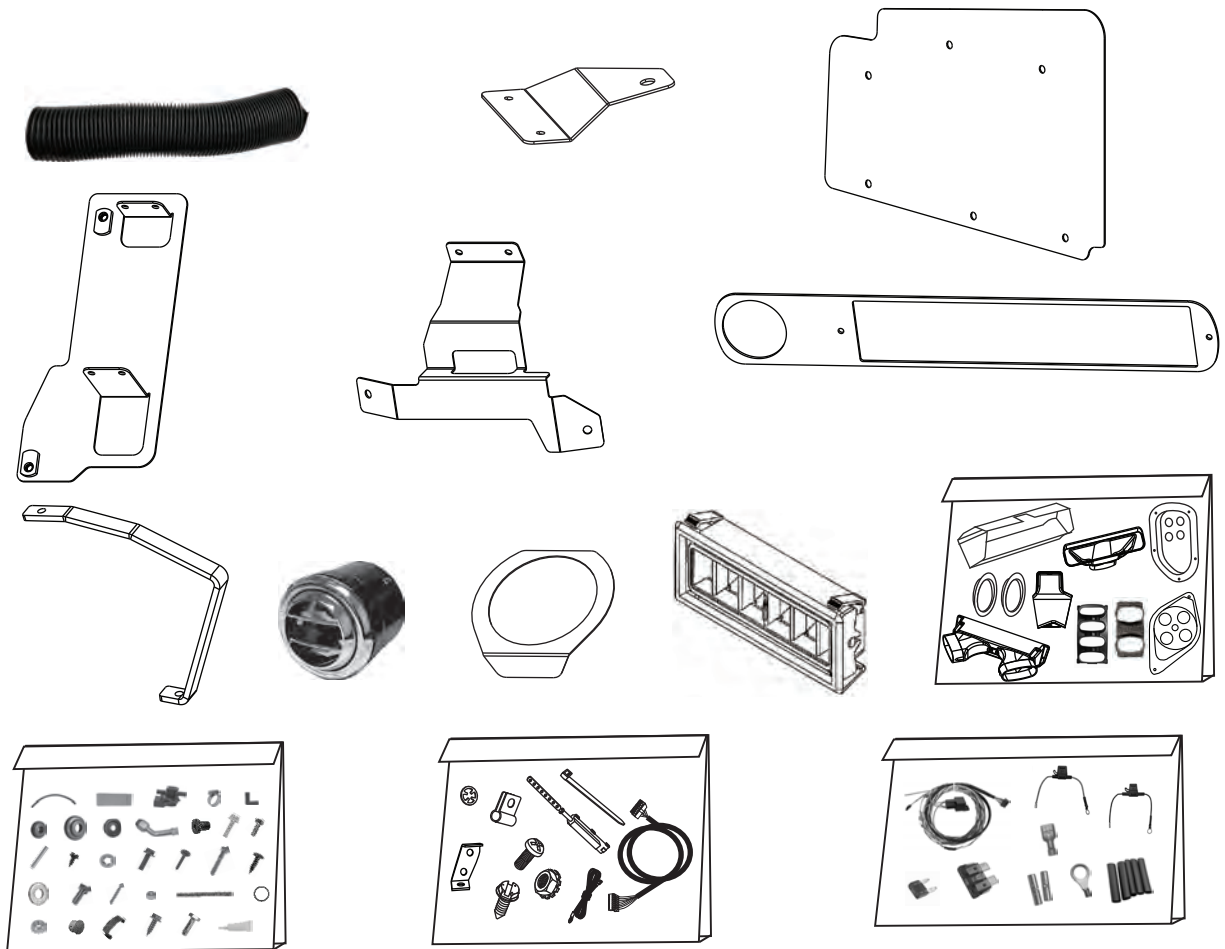

**Accessory Kit
781273**

**NOTE: Images may not depict actual parts and quantities.
Refer to packing list for actual parts and quantities.**